

# MOUNTING AND OPERATING INSTRUCTIONS

**SAMSON**

EB005.022 EN

Translation of Original Instructions

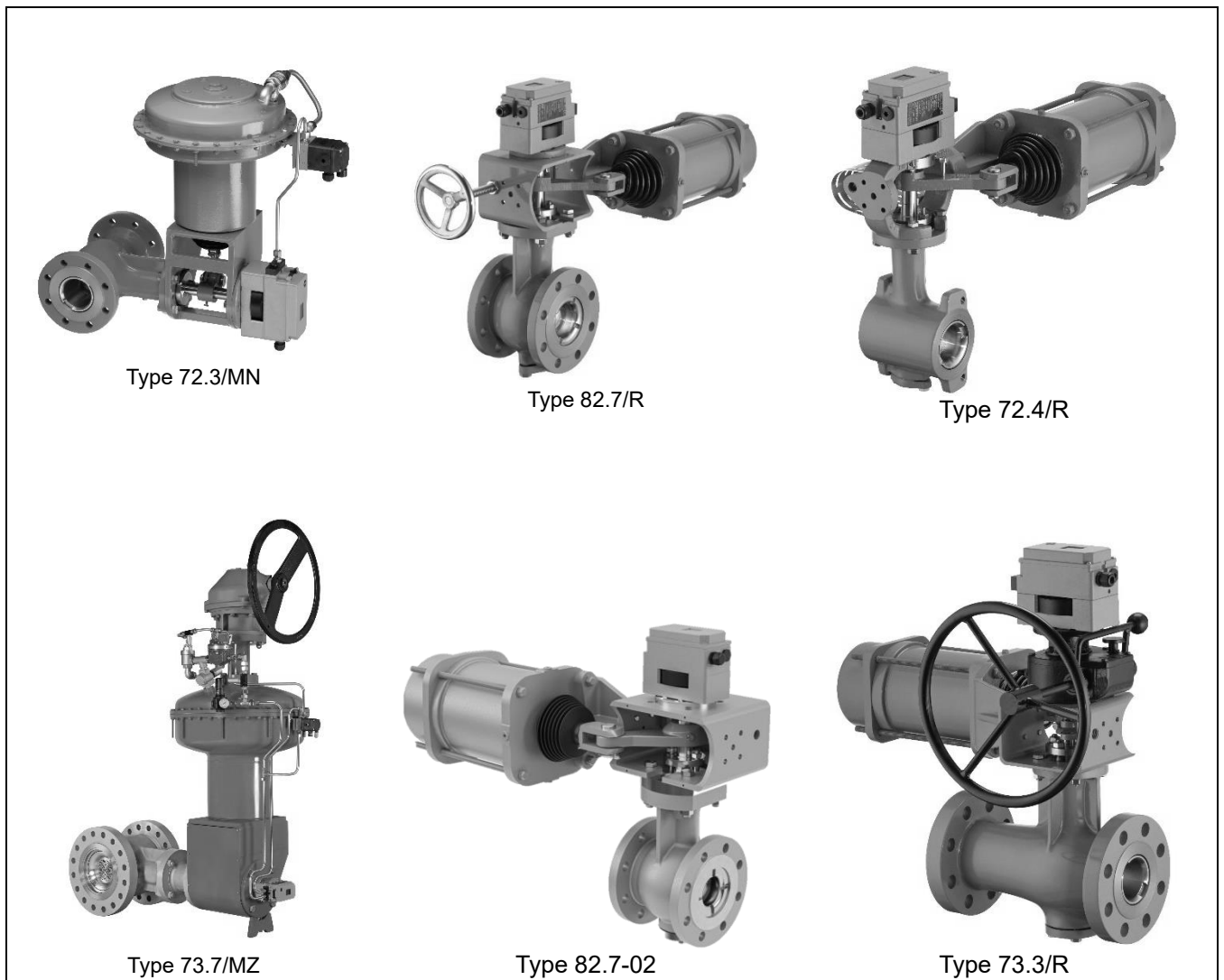

## **Valve Series 82, 72, 73**

in combination with a pneumatic diaphragm actuator (e.g., Type R, MD, MN, MZ)

Edition June 2024 (Rev.07 / 31.03.2026)

## Note on these mounting and operating instructions

These mounting and operating instructions assist you in mounting and operating the device safely. The instructions are binding for handling SAMSON VETEC devices. The images shown in these instructions are for illustration purposes only. The actual product may vary.

- For the safe and proper use of these instructions, read them carefully and keep them for later reference.
- If you have any questions about these instructions, contact SAMSON VETEC After-sales Service:  
sales-vetec-de@samsongroup.com

### Definition of signal words

---

#### **DANGER**

→ *Hazardous situations which, if not avoided, will result in death or serious injury*

---

---

#### **NOTICE**

→ *Property damage message or malfunction*

---

---

#### **WARNING**

→ *Hazardous situations which, if not avoided, could result in death or serious injury*

---

---

#### **Note**

→ *Additional information*

---

---

#### **Tip**

→ *Recommended action*

---

## Content

<b>1</b>	<b>Safety instructions and measures</b> .....	<b>1-1</b>
1.1	Notes on possible severe personal injury .....	1-3
1.2	Notes on possible personal injury .....	1-4
1.3	Notes on possible property damage .....	1-5
1.4	Special notes .....	1-6
1.5	Warnings on the device .....	1-6
<b>2</b>	<b>Markings on the device</b> .....	<b>2-1</b>
<b>3</b>	<b>Design and principle of operation</b> .....	<b>3-3</b>
3.1	Fail-safe positions of the valve with single-acting actuator.....	3-8
3.2	Additional fittings (Strainers, bypass/shut-off valves, silencer etc.).....	3-8
3.3	Technical data .....	3-10
<b>4</b>	<b>Shipment and on-site transport</b> .....	<b>4-1</b>
4.1	Accepting the delivered goods.....	4-1
4.2	Removing the packaging from the valve .....	4-1
4.3	Transporting and lifting the valve .....	4-1
4.3.1	Transporting the valve .....	4-3
4.3.2	Lifting the valve .....	4-3
4.4	Storing the valve .....	4-6
<b>5</b>	<b>Installation</b> .....	<b>5-1</b>
5.1	Installation conditions .....	5-1
5.1.1	Support or suspension of the valve in the pipeline .....	5-2
5.2	Preparation for installation .....	5-3
5.3	Mounting the device (actuator onto the valve).....	5-7
5.4	Installing the valve into the pipeline .....	5-7
5.4.1	Installing the valve Type 72.4 (Wafer lug) into the pipeline .....	5-9
5.5	Testing the installed valve .....	5-10
5.5.1	Leak test .....	5-11
5.5.2	Rotary motion.....	5-12
5.5.3	Fail-safe position.....	5-12
5.5.4	Pressure test.....	5-12
<b>6</b>	<b>Start-up</b> .....	<b>6-1</b>
<b>7</b>	<b>Operation</b> .....	<b>7-1</b>
7.1	Normal operation .....	7-2
7.2	Manual operation .....	7-2
<b>8</b>	<b>Malfunctions</b> .....	<b>8-1</b>
8.1	Troubleshooting .....	8-1
8.2	Emergency action .....	8-2
<b>9</b>	<b>Servicing</b> .....	<b>9-1</b>
9.1	Periodic testing .....	9-4
9.2	Preparing the valve for service work.....	9-5

9.3	Installing the valve after service work.....	9-5
9.4	Service work .....	9-5
9.4.1	Retightening/adjusting the stuffing box packing .....	9-6
9.5	Ordering spare parts and operating supplies .....	9-7
<b>10</b>	<b>Decommissioning</b> .....	<b>10-1</b>
<b>11</b>	<b>Removal</b> .....	<b>11-1</b>
11.1	Removing the valve from the pipeline.....	11-2
11.2	Removing the actuator from the valve .....	11-2
<b>12</b>	<b>Repairs</b> .....	<b>12-1</b>
12.1	Returning devices to SAMSON VETEC .....	12-1
<b>13</b>	<b>Disposal</b> .....	<b>13-1</b>
<b>14</b>	<b>After-sales service</b> .....	<b>14-1</b>

# 1 Safety instructions and measures

## Intended use

SAMSON VETEC devices are designed to operate under exactly defined conditions (e.g., operating pressure, process medium, temperature etc.). Therefore, operators must ensure that the valve is only used in operating conditions that meet the specifications used for sizing the valve at the ordering stage. In case operators intend to use the valve in other applications or conditions than specified, contact SAMSON VETEC.

SAMSON VETEC does not assume any liability for damage resulting from the failure to use the device for its intended purpose or for damage caused by external forces or any other external factors.

→ Refer to the technical data sheets, valve specification and nameplate for limits and fields of application as well as possible uses.

## Reasonably foreseeable misuse

The valve is not suitable for the following applications:

- Use outside the limits defined during sizing and by the technical data.
- Use outside the limits defined by the valve accessories connected to the valve

Furthermore, the following activities do not comply with the intended use:

- Use of non-original spare parts
- Performing service and repair work not described

## Qualifications of operating personnel

The valve must be mounted, started up, serviced and repaired by fully trained and qualified personnel only; the accepted industry codes and practices must be observed. According to these mounting and operating instructions, trained personnel refer to individuals who are able to judge the work they are assigned to and recognize possible hazards due to their specialized training, their knowledge and experience as well as their knowledge of the applicable standards. Welding operations must only be performed by personnel who has the necessary qualification to perform the applied welding procedure and handle the materials used. Explosion-protected versions of this device must be operated only by personnel who has undergone special training or instructions or who is authorized to work on explosion-protected devices in hazardous areas.

## Personal protective equipment

We recommend checking the hazards posed by the process medium being used (e.g., GESTIS CLP) hazardous substances database). Depending on the process medium and/or the activity, the protective equipment required includes:

- Protective clothing, gloves, eye protection and respiratory protection in applications with hot, cold and/or corrosive media
  - Wear hearing protection when working near the valve
  - Hard hat
  - Safety harness when working at height
  - Safety footwear, ESD (electrostatic discharge) footwear, if necessary.
- Check with the plant operator for details on further protective equipment.

## Revisions and other modifications

Revisions, conversions, or other modifications of the product are not authorized by SAMSON VETEC. They are performed at the user's own risk and may lead to safety hazards, for example. Furthermore, the product may no longer meet the requirements for its intended use.

## Safety features

The fail-safe position of the valve upon air supply or control signal failure depends on the actuator used (see associated actuator documentation). When the valve is combined with pneumatic actuator, the valve moves to a certain fail-safe position (see the 'Design and principle of operation' section) upon supply air or control signal failure. The fail-safe action of the actuator is the same as its direction of action and is specified on the nameplate of SAMSON VETEC actuators.

## Warning against residual hazards

To avoid personal injury or property damage, plant operators and operating personnel must prevent hazards that could be caused in the valve by the process medium, the operating pressure, the signal pressure or by moving parts by taking appropriate precautions. Plant operators and operating personnel must observe all hazard statements, warning, and caution notes in these mounting and operating instructions.

Hazards resulting from the special working conditions at the installation site of the valve must be identified in a risk assessment and prevented through the corresponding safety instructions drawn up by the operator.

## Responsibilities of the operator

Operators are responsible for proper use and compliance with the safety regulations. Operators are obliged to provide these mounting and operating instructions as well as the referenced documents to the operating personnel and to instruct them in proper operation. Furthermore, operators must ensure that operating personnel or third parties are not exposed to any danger.

Operators are additionally responsible for ensuring that the limits for the product defined in the technical data are observed. This also applies to the start-up and shutdown procedures. Start-up and shutdown procedures fall within the scope of the operator's duties and, as such, are not part of these mounting and operating instructions. SAMSON is unable to make any statements about these procedures since the operative details (e.g., differential pressures and temperatures) vary in each individual case and are only known to the operator.

## Responsibilities of operating personnel

Operating personnel must read and understand these instructions as well as the referenced documents and observe the specified hazard statements, warnings, and caution notes. Furthermore, operating personnel must be familiar with the applicable health, safety and accident prevention regulations and comply with them.

## Referenced standards, directives, and regulations

The valves comply with the requirements of the European Pressure Equipment Directive 2014/68/EU and the Machinery Directive 2006/42/EC. Valves with a CE marking have a declaration of conformity, which includes information about the applied conformity assessment procedure. The 'Certificates' section contains this declaration of conformity.

Non-electric valve versions whose bodies are not lined with an insulating material coating do not have their own potential ignition source according to the risk assessment stipulated in Clause 5.2 of ISO 80079-36, even in the rare incident of an operating fault. Therefore, such valve versions do not fall within the scope of Directive 2014/34/EU.

The electric actuators are intended for use in low-voltage systems. During connection, commissioning, operation, maintenance and repair, the plant operator must observe all legal requirements, directives, regulations, national rules and recommendations. See the associated documentation of the actuator.

→ For connection to the equipotential bonding system, observe the requirements specified in Clause 6.4 of EN 60079-14 (VDE 0165-1).

## Referenced documentation

The following documents apply in addition to these mounting and operating instructions:

- Mounting and operating instructions for the mounted actuator
- Mounting and operating instructions for mounted accessories
- Data sheet valve, actuator, and accessories
- Data sheet for the installation position of the valve in the pipeline ► TY005.071
- Data sheet for silencer/noise reducer (if applicable)
- Instructions for markings on the device ► EB005.069
- Instructions for on-site transport (transporting and lifting the valve). See section '4.3.2 Lifting the valve'.
- Instructions for supporting/suspending the valve with actuator (if applicable). See section '5.1.1 Support or suspension'.
- Instructions for servicing/maintenance of the valves. Contact SAMSON VETEC After-sales Service: sales-vetec-de@samsongroup.com.
- Manual ► H 02: Appropriate Machinery Components for SAMSON VETEC Pneumatic Control Valves
- Additional manuals for special applications (e.g., oxygen application).  
Valves for oxygen are marked with the following label:

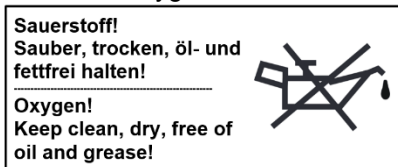

- When a substance is used in the device, which is listed as being a substance of very high concern on the candidate list of the REACH regulation:  
Information on safe use of the part affected, see ► [www.samsongroup.com](http://www.samsongroup.com) > About SAMSON > Environment, Social & Governance > Material Compliance > REACH.

## 1.1 Notes on possible severe personal injury



### Risk of bursting in pressure equipment.

Valves and pipelines are pressure equipment. Impermissible pressure or improper opening can lead to valve components bursting.

- ➔ Observe the maximum permissible pressure for valve and plant.
- ➔ Before starting any work on the valve, depressurize all plant sections affected as well as the valve.
- ➔ Drain the process medium from all the plant sections concerned as well as the valve.

## 1.2 Notes on possible personal injury



### **Risk of burn injuries due to hot or cold components and pipelines.**

Depending on the process medium, valve components and pipelines may get very hot or cold and cause burn injuries.

- Allow components and pipelines to cool down or warm up to the ambient temperature.
- Wear protective clothing and safety gloves.

### **Risk of hearing loss or deafness due to loud noise.**

The noise emissions depend on the valve version, plant facilities and process medium.

- Wear hearing protection when working near the valve.

### **Risk of personal injury due to exhaust air being vented.**

While the valve is operating, air is vented from the actuator, for example, during closed-loop operation or when the valve opens or closes.

- Install the valve in such a way that vent openings are not located at eye level and the actuator does not vent at eye level in the work position.
- Use suitable silencers and vent plugs.
- Wear eye protection when working in close proximity to the valve.

### **Crush hazard arising from moving parts.**

The valve contains moving parts (actuator piston rod/lever and valve shaft), which can injure hands or fingers if inserted into the valve.

- Do not insert hands or finger into the bracket while the air supply is connected to the actuator.
- Before working on the valve, disconnect and lock the pneumatic air supply as well as the control signal.
- Do not impede the movement of the actuator piston rod/lever and valve shaft by clamping objects.
- Before unblocking the actuator piston rod and valve shaft after they have become blocked (e.g., due to seizing up after remaining in the same position for a long time), release any stored energy in the actuator (e.g., spring compression). See associated actuator documentation.

### **Risk of personal injury due to preloaded springs!**

Actuators with preloaded springs are under tension.

- Before starting any work on the actuator, relieve the compression from the preloaded springs (see associated actuator documentation).

### **Risk of personal injury due to residual process medium in the valve!**

While working on the valve, residual medium can flow out of the valve and, depending on its properties, cause personal injury, e.g. (chemical) burns.

- If possible, discharge the medium from the affected pipeline sections and the valve.
- Wear protective clothing, safety gloves, respiratory protection and eye protection.

## **WARNING**

### **Risk of personal injury through incorrect operation, use or installation as a result of information on the valve being illegible!**

Over time, markings, labels and nameplates on the valve may become covered with dirt or become illegible in some other way. As a result, hazards may go unnoticed, and the necessary instructions not followed. There is a risk of personal injury.

- Keep all relevant markings and inscriptions on the device in a constantly legible state.
- Immediately renew damaged, missing, or incorrect nameplates or labels.

## **1.3 Notes on possible property damage**

### **NOTICE**

#### **Risk of valve damage due to contamination (e.g., solid particles) in the pipeline.**

The plant operator is responsible for cleaning the pipelines in the plant.

- Flush the pipelines before start-up.

#### **Risk of valve damage due to contamination (e.g. solid particles) in the pipeline.**

The plant operator is responsible for cleaning the pipelines in the plant.

- Flush the pipelines before start-up.

#### **Risk of valve damage due to unsuitable medium properties.**

The valve is designed for a process medium with defined properties.

- Only use the process medium specified for sizing the valve.

#### **Risk of leakage and valve damage due to excessively high or low tightening torques.**

Observe the specified torques when tightening valve components. Excessive tightening torques lead to parts wearing out more quickly. Parts that are too loose may cause leakage.

- Observe the specified tightening torques.

#### **Risk of valve damage due to the use of unsuitable tools.**

Certain tools are required to work on the valve.

- Only use tools approved by SAMSON VETEC.

#### **Risk of valve damage due to the use of unsuitable lubricants.**

The lubricants to be used depend on the valve material. Unsuitable lubricants may corrode and damage surfaces.

- Only use approved lubricants.

#### **Risk of the process medium being contaminated through the use of unsuitable lubricants and/or contaminated tools and components.**

- If necessary (e.g. for oxygen service), keep the valve and the tools used free from solvents and grease.
- Make sure that only suitable lubricants are used that have been tested for pressure, temperature, and media compatibility.
- For critical applications (e.g. oxygen) follow the cleaning instructions. Ensure cleanliness in accordance with standards.



## 1.4 Special notes

Electrostatic charges can build up on valve housings during plant operation. In the event of electrostatic discharge (ESD), this can lead to a risk of ignition of flammable gases, vapours, or dust in potentially explosive areas, as well as damage to electronic components.

Safety measures:

- Ground persons and equipment.
- Avoid electrostatic charges: clean equipment only with a damp cloth.

## 1.5 Warnings on the device

Warning	Meaning of the warning
 <p data-bbox="164 763 549 792"><b>Fig. 1-1:</b> Warning of bursting hazard</p>	<p data-bbox="764 656 1501 719"><b>Warning against bursting when loosening the screws on the actuator cover</b></p> <p data-bbox="764 719 1501 808">There is a risk of injury due to preloaded spring of the actuator. Before starting any work on the actuator, relieve the compression from the preloaded springs.</p>
 <p data-bbox="164 1037 719 1066"><b>Fig. 1-2:</b> Warning of injury arising from moving parts</p>	<p data-bbox="764 840 1150 869"><b>Warning against moving parts</b></p> <p data-bbox="764 869 1501 958">There is a risk of crushing due to the movement of the actuator lever/valve shaft, while the air supply is connected to the actuator.</p> <p data-bbox="764 958 1501 987">Do not reach into the bracket when operating the valve.</p> <p data-bbox="764 987 1501 1050">When working on the valve, disconnect and lock the supply air.</p>
 <p data-bbox="164 1301 719 1352"><b>Fig. 1-3:</b> Warning of hearing loss or deafness due to loud noise</p>	<p data-bbox="764 1081 1501 1144"><b>Warning against hearing loss or deafness due to high noise emissions</b></p> <p data-bbox="764 1144 1501 1234">A brief loud noise may occur through the sudden venting of the pneumatic actuator or pneumatic valve accessories not fitted with noise-reducing fittings.</p> <p data-bbox="764 1234 1501 1323">Noise emission (e.g. cavitation or flashing) may additionally occur during operation caused by the process medium and the operating conditions.</p> <p data-bbox="764 1323 1409 1352">Wear hearing protection when working near the valve.</p>

## Location of the warnings on the valve

Configuration samples · Pneumatic valves

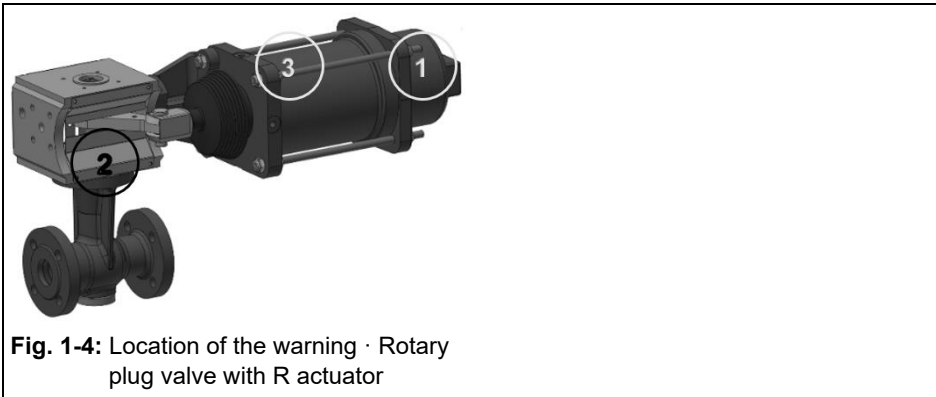

Warning	Position
	1
	2
	3

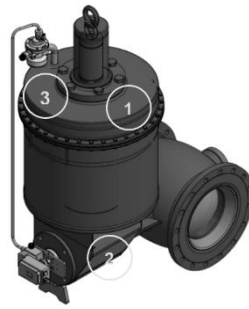
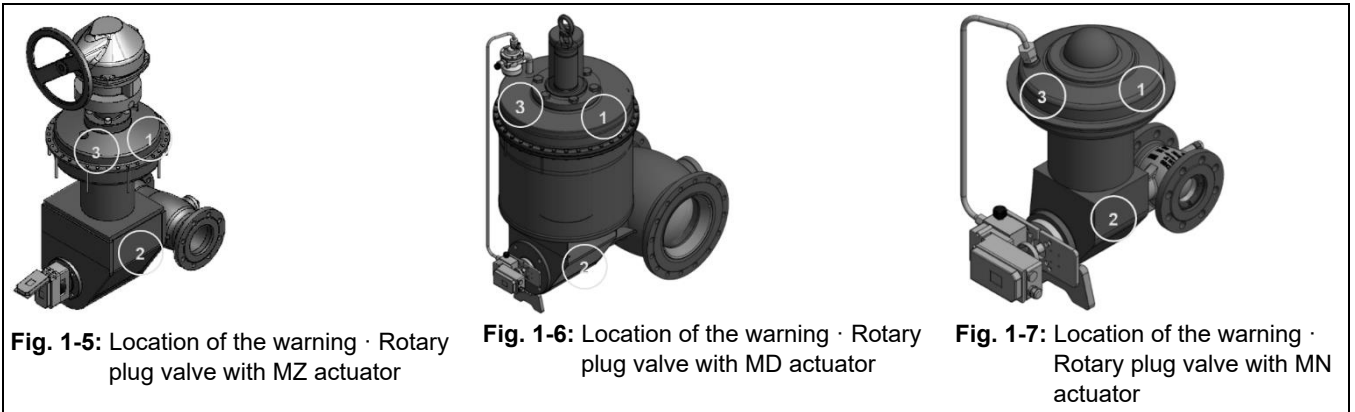

## 2 Markings on the device

The valves are always marked with the SAMSON VETEC nameplate, no. 11. Exceptions are the valves delivered to the Eurasian Union (EB005.046), which are marked with the nameplates no.13 and 14 and to China, which are marked with the nameplate no. 21.

Depending on the valve design, applications and customer specifications, additional markings are possible or required.

For markings see associated documentation ►EB005.069

### Conformity

Conformity with the PED 2014/68/EU and the Machinery Directive 2006/42/EC is documented on the nameplate with the CE symbol.

The nameplate provides information about the design of the valve.

### **i** Note

Detailed technical information according to the data sheets (of the valve, actuator, etc.) and valve specification.

### Nameplate No. 11

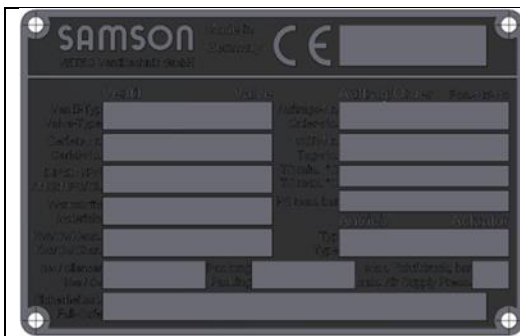

Fig. 2-1: Nameplate No. 11

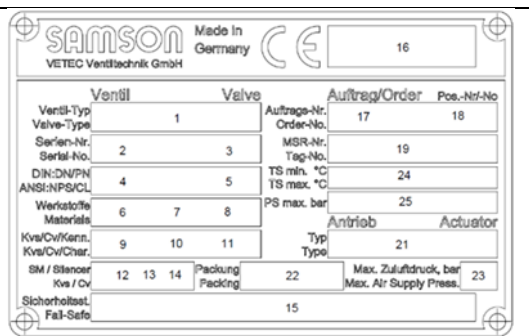

Fig. 2-2: Inscriptions of the nameplate no. 11

#### Item Inscription meaning

- 1 Valve type
- 2 Valve serial no.
- 3 Year of manufacture
- 4 Nominal size: DN (DIN) · NPS (ANSI)
- 5 Rated pressure: PN (DIN) · CL (ANSI)
- 6 Body material
- 7 Seat material
- 8 Seat facing: **ME** (metallic) · **PT** (soft-sealing PTFE) · **KE** (Ceramic) · **Hard metal** (manufacturer's designation)
- 9 Flow coefficient: Kvs-value (DIN) of the mounted seat ring
- 10 Flow coefficient: Cv-value (ANSI) of the mounted seat ring
- 11 Flow characteristic: % (equal percentage) · **LIN** (linear) · **INH** (natural) · **ON/OFF** operation
- 12 Type of noise reduction: for VETEC noise reduction → SM1.0/1.5; SM 2.0/2.5; SM 3.0/3.5; SM 4.5; SM 8.0; SM 8.1; SM 9.1; SM 9.2; 'Free field' for valve without noise reduction
- 13 Flow coefficient: Kvs value (DIN) of noise reduction; 'free field' for valve without noise reduction
- 14 Flow coefficient: Cv value (ANSI) of noise reduction; 'free field' for valve without noise reduction
- 15 Fail-safe position without power supply: **FC** (spring closes) · **FO** (spring opens) · **STOP**
- 16 CE mark / identification no. of the Inspection Body
- 17 VETEC order number
- 18 VETEC order item (position)
- 19 Tag no.
- 20 N.a.

- 21 Actuator Type
- 22 Packing design: "free field" for standard packing · TA-Luft for packings with O-rings.
- 23 Max. permissible supply air pressure in bar(g) with pneum. Actuator or "0" for electric actuator
- 24 Design temperature in °C: min. and max. value
- 25 Max. permissible operating pressure in bar(g); if not available, max. design pressure in bar(g)

### Location of the nameplate no. 11 on the valve

The nameplate is located on the actuator or on the bracket on the side of the seat or lever. For deliveries without actuator, attached to the valve neck.

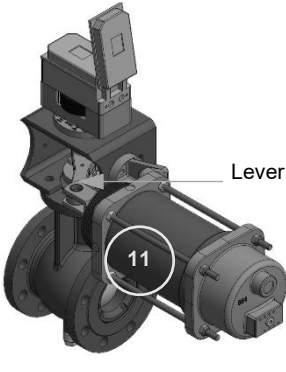
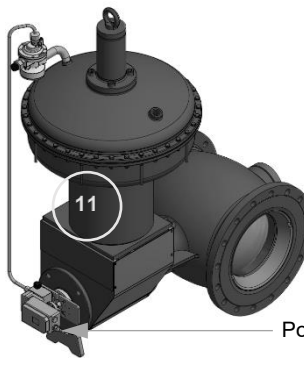
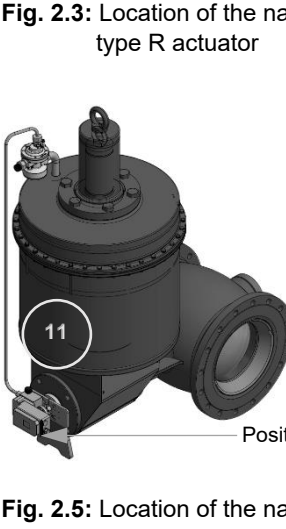
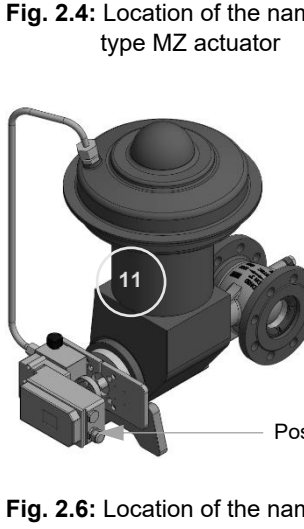
	<p>Nameplate no.11 is located on the actuator on the side of the lever.</p>		<p>Nameplate no.11 is located on the actuator on the side of the positioner.</p>
	<p>Nameplate no.11 is located on the actuator on the side of the positioner.</p>		<p>Nameplate no.11 is located on the actuator on the side of the positioner.</p>
<p><b>Fig. 2.3:</b> Location of the nameplate no.11 on the valve with type R actuator</p> <p><b>Fig. 2.4:</b> Location of the nameplate no.11 on the valve with type MZ actuator</p> <p><b>Fig. 2.5:</b> Location of the nameplate no.11 on the valve with type MD actuator</p> <p><b>Fig. 2.6:</b> Location of the nameplate no.11 on the valve with type MN actuator</p>			

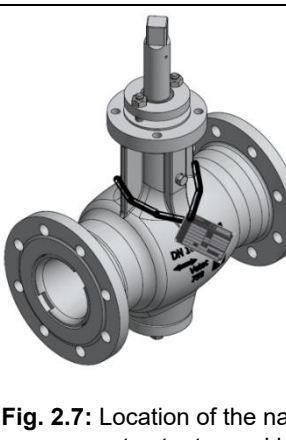
	<p>Nameplate no. 11 is attached to the valve neck with cable ties.</p>
<p><b>Fig. 2.7:</b> Location of the nameplate no.11 on the valve without actuator and bracket</p>	

### 3 Design and principle of operation

SAMSON VETEC Series 82, 72, 73 are double eccentric rotary plug valves for process engineering and industrial applications.

The valves can be operated with pneumatic, electric, as well as hydraulic rotary actuators and can be equipped with various accessories such as positioners, solenoid valves, limit switches and others according to DIN EN 60534-6, VDI/VDE 3845, or NAMUR recommendation.

#### Configuration examples of rotary plug valves with actuators Type R, MD, MN, MZ

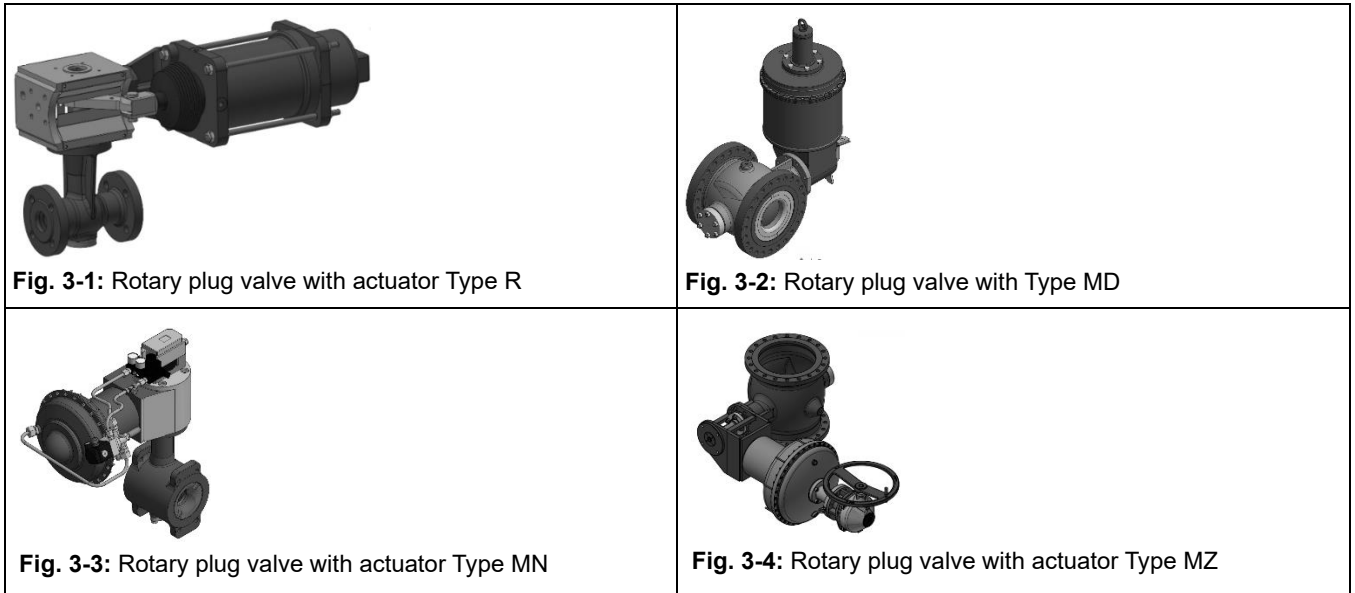

#### Standard designs

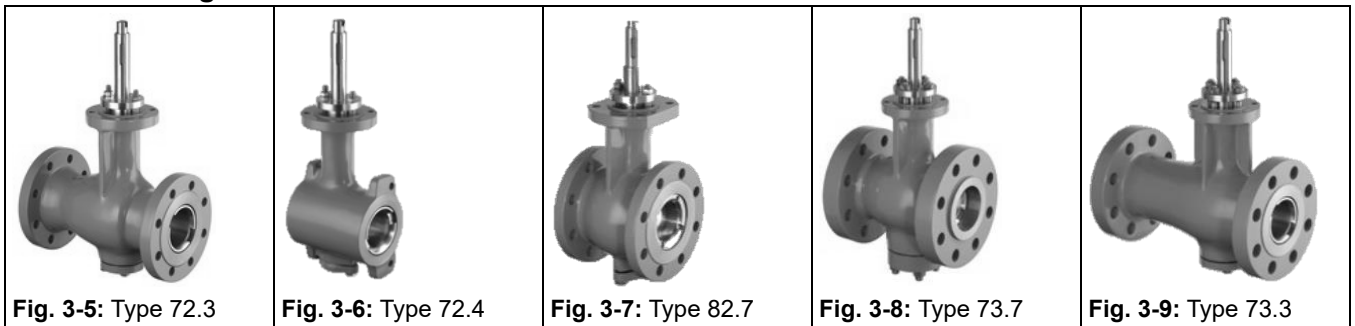

#### Other designs

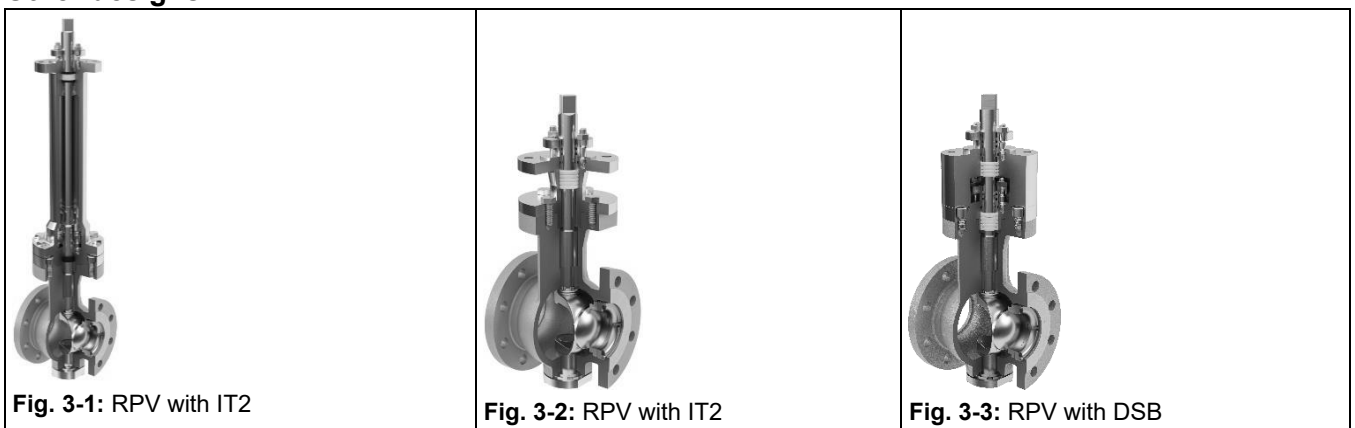

### Other designs

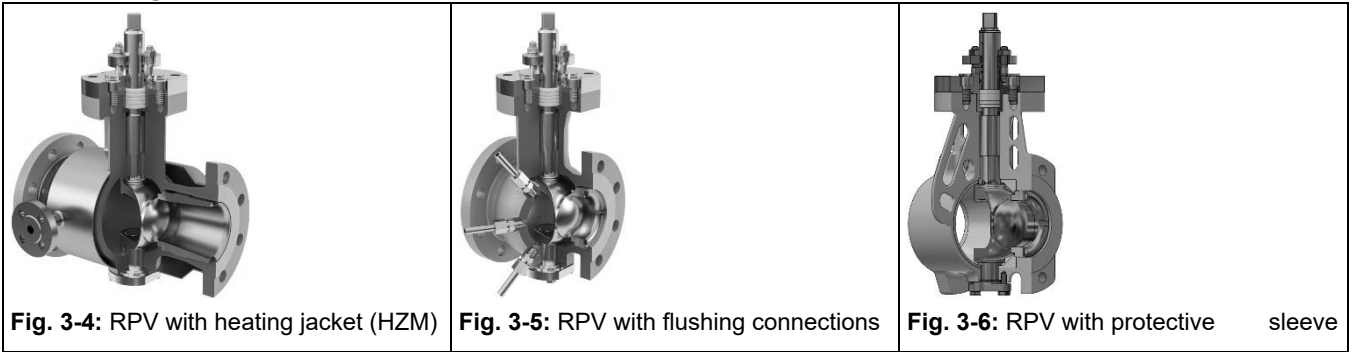

### Design changes (valve generation 02)

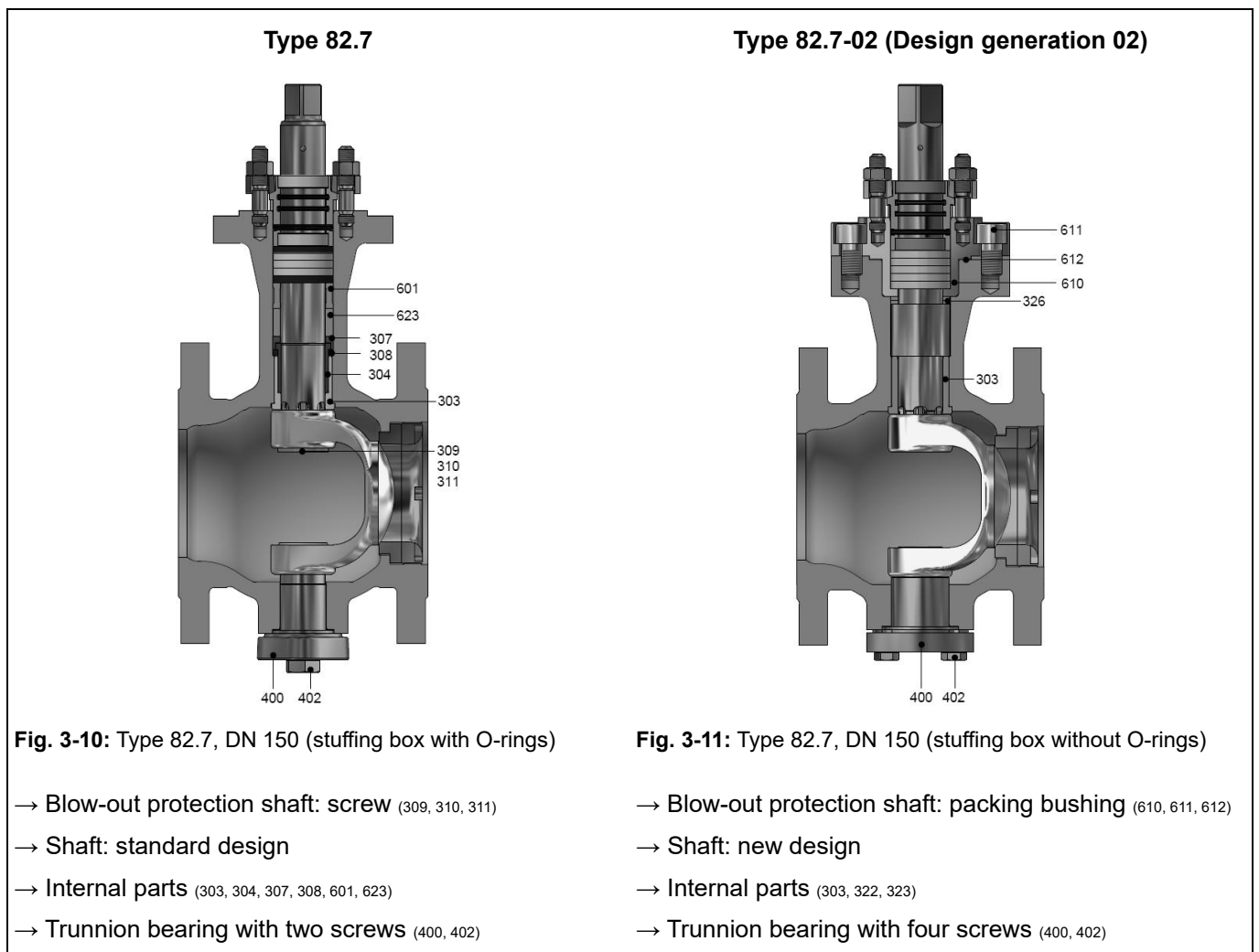
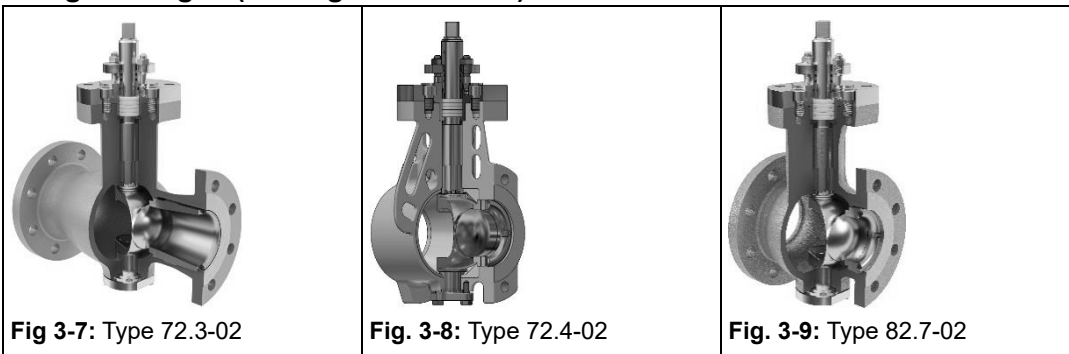

**Type 72.3**

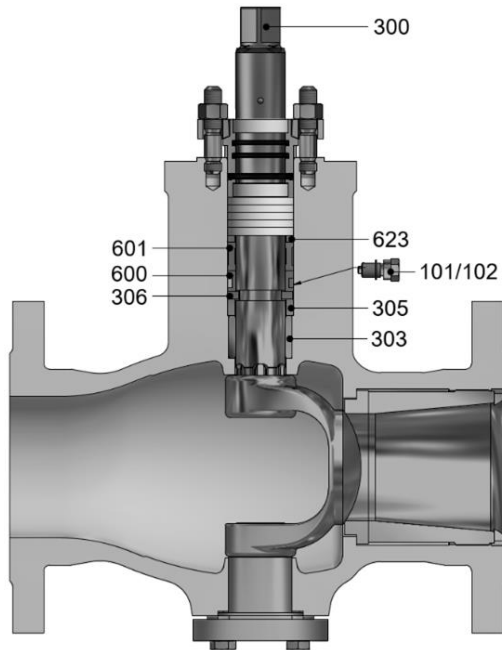

**Fig. 3-10:** Type 72.3, DN 100 (stuffing box with O-rings)

- Blow-out protection shaft: screw (101/102)
- Shaft: standard design
- Internal parts (303, 305, 306, 600, 601)

**Type 72.3-02 (design generation 02)**

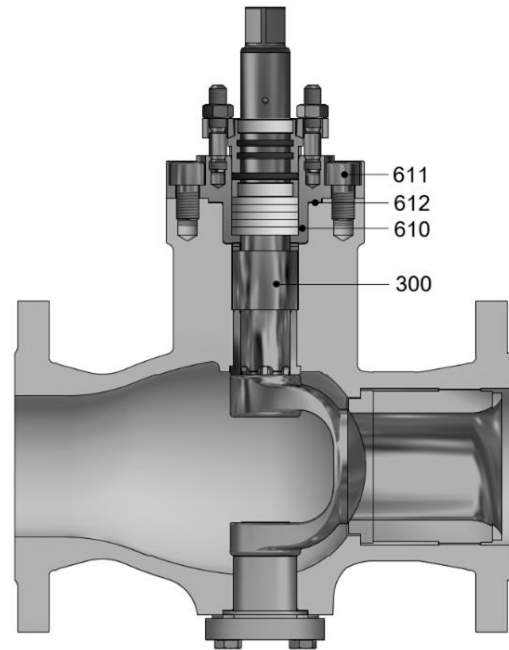

**Fig. 3-11:** Type 72.3-02, DN 100 (stuffing box with O-rings)

- Blow-out protection shaft: packing bushing (610, 611, 612)
- Shaft: new design
- Internal parts (303, 326)

**Type 72.4**

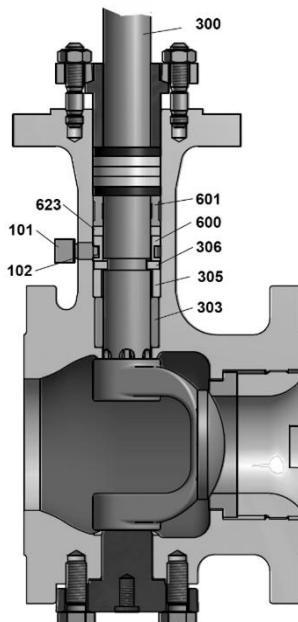

**Fig. 3-12:** Type 72.4, DN 100 (stuffing box with O-rings)

- Blow-out protection shaft: screw (101/102)
- Shaft: standard design
- Internal parts (303, 305, 306, 600, 601)

**Type 72.4-02 (design generation 02)**

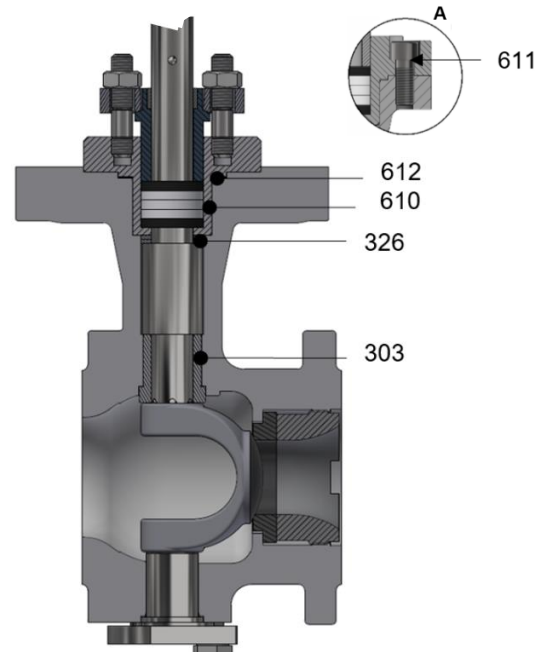

**Fig. 3-13:** Type 72.4-02, DN 100 (stuffing box with O-rings)

- Blow-out protection shaft: packing bushing (610, 611, 612)
- Shaft: new design
- Internal parts (303, 326)

### Double eccentric design

The bearing of the shaft in connection with the trim is eccentrically arranged. The double eccentric geometry of the rotary plug valve is realized together with the offset of the plug's centre of rotation. This double-eccentric bearing arrangement causes the plug to lift smoothly and immediately from the seat when the shaft rotates from the closed position in the opening direction. The valve does not open jerkily and therefore shows a stable control behaviour even at small opening angles.

**Series 72, 73 and 82 valves close counterclockwise and have an opening angle of 75°.**

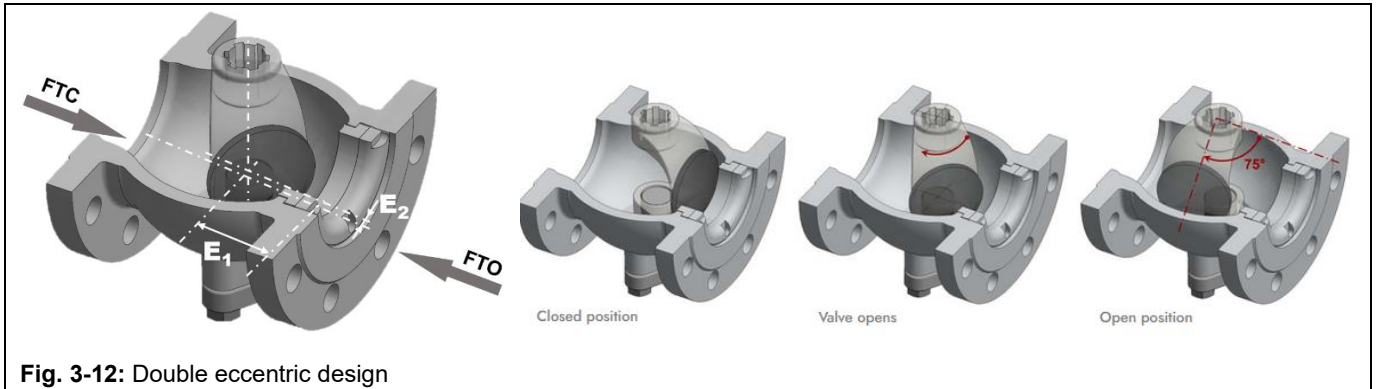

**Fig. 3-12:** Double eccentric design

## Principle of operation

The seat (500/501) and plug (200) with shaft (300) are installed in the valve body (100). The valve shaft is connected to the actuator and is sealed by packing rings (620/621) and O-Rings (for TA-Luft version).

A change in the signal pressure acting on the actuator causes the shaft/plug to rotate.

The medium flows through the valve in the direction indicated by the arrow. A rise in signal pressure causes the force acting on the diaphragm in the actuator to increase. The springs are compressed. The actuator piston rod extends and rotates the lever, which is directly connected with the valve shaft (300). As a result, the plug position in the seat changes and determines the flow rate through the valve.



**Tip**

We recommend the use of SAMSON positioner with integrated diagnostic firmware for valves used for on/off service. The partial stroke test included in this software helps prevent a shut-off valve normally in its end position from seizing up or getting jammed.

---

Example: Principle of operation illustrated with a valve with pneumatic actuator Type R

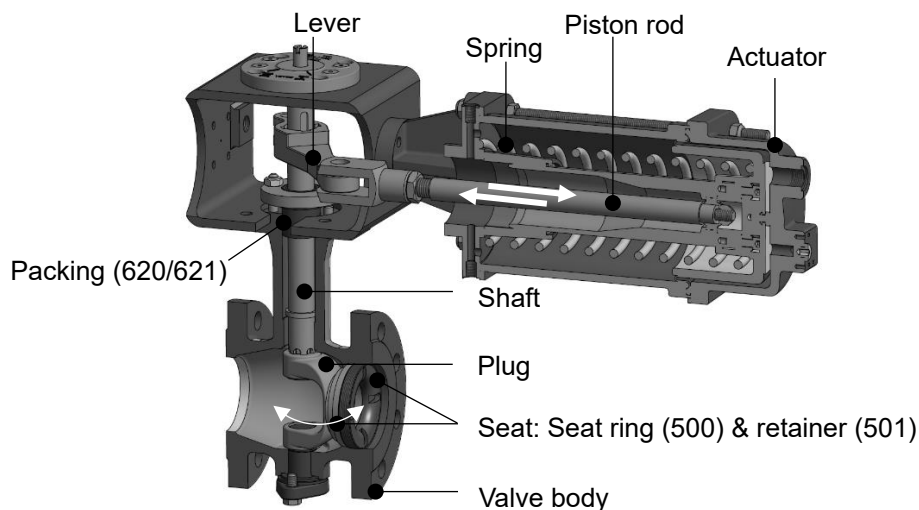

**Fig. 3-13:** Rotary plug valve with actuator Type R · Principle of operation

### 3.1 Fail-safe positions of the valve with single-acting actuator

Depending on the actuator's direction of action (see the associated actuator documentation), the valve has one of the following fail-safe positions:

- **Spring force closes (FC):** When the signal pressure is reduced or the air supply fails, the spring (springs, depending on actuator type) moves the piston rod resp. the lever and closes the valve. The valve opens when the signal pressure increases against the force of the springs.
- **Spring force opens (FO):** When the signal pressure is reduced or the air supply fails, the spring (springs, depending on actuator type) moves the piston rod resp. the lever and opens the valve. The valve closes when the signal pressure increases against the force of the springs.

Example: Fail-safe positions illustrated with a valve with pneumatic actuator Type R · Mounting position A

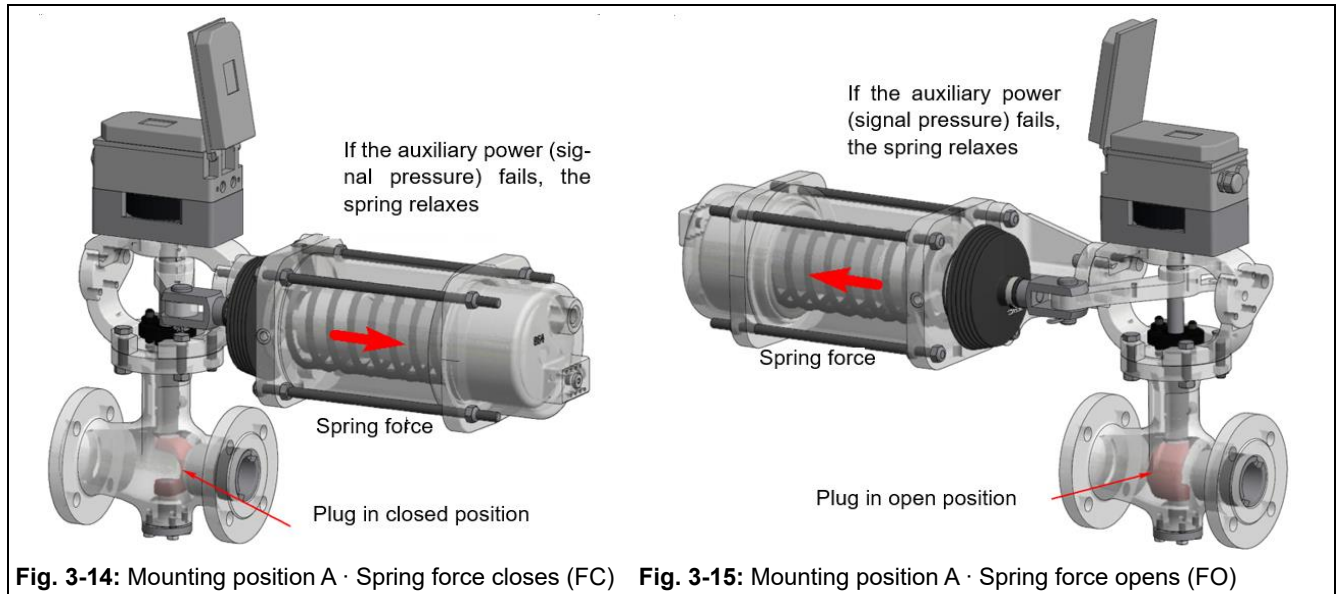

Fig. 3-14: Mounting position A · Spring force closes (FC) Fig. 3-15: Mounting position A · Spring force opens (FO)

### 3.2 Additional fittings (Strainers, bypass/shut-off valves, silencer etc.)

#### Strainers

We recommend installing a SAMSON VETEC strainer upstream of the valve. It prevents solid particles in the process medium from damaging the valve.

#### Bypass and shut-off valves

We recommend installing a shut-off valve both upstream of the strainer and downstream of the valve and installing a bypass line. The bypass ensures that the plant does not need to be shut down for service and repair work on the valve.

#### Insulation

Valves can be insulated to reduce heat energy transfer.

→ Refer to the instructions in the 'Installation' section.

#### Test connection

For the version with double stuffing box (DSB), a test connection can be used to monitor the tightness of the double stuffing box.

We recommend installing a suitable leakage indicator (e.g. a contact pressure gauge). The selection and installation of the leakage indicator is the responsibility of the operator.

## Safety guard

For operating conditions that require increased safety (e.g. in cases where the valve is freely accessible to untrained staff), a safety guard must be installed to rule out a crush hazard arising from moving parts (actuator and plug shaft). Plant operators are responsible for deciding whether a guard is to be used. The decision is based on the risk posed by the plant and its operating conditions.

## Silencer (Noise reducer)

SAMSON VETEC silencers can be used to minimise noise emission, cavitation, and erosion. They can be adapted to the respective operating conditions and, depending on the type, are effective in both flow directions. Existing valves can be upgraded with SAMSON VETEC silencers.



Refer to the following documents:

- Overview SAMSON VETEC silencers ►TY005.036
- Data sheet silencer Type SM 1.0/1.5 ►TY005.028
- Data sheet silencer Type SM 2.0/2.5 ►TY005.023
- Data sheet silencer Type SM 2.0/2.5 (for high pressure) ►TY005.024
- Data sheet silencer Type SM 3.0/3.5 ►TY005.025
- Data sheet silencer Type SM 4.5 ►TY005.034
- Data sheet silencer Type SM 8.0 ►TY005.019
- Data sheet silencer Type SM 8.1 ►TY005.035
- Data sheet silencer Type SM 9.1 ►TY005.020
- Data sheet silencer Type SM 9.2 ►TY005.021



### 3.3 Technical data

The nameplates on the valve and actuator provide information on the valve version. For nameplate see the 'Markings on the device' section.

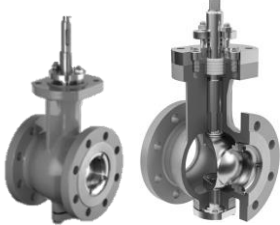
**Table 3-1:** Valves for standard and heavy-duty applications

Type 72.3	Type 72.4	Type 82.7 / 82.7-02
		
<b>Face-to-face dimensions</b> DIN EN 558 R 1, 15	<b>Face-to-face dimensions</b> DIN EN 558 R 36	<b>Face-to-face dimensions</b> DIN EN 558 R 36
<b>Size</b> DN 25 to 600 / NPS 1 to 24	<b>Size</b> DN 25 to 300 / NPS 1 to 12	<b>Size</b> DN 25 to 300 / NPS 1 to 12 DN 25 to 350 / NPS 1 to 14 (Type 82.7-02)
<b>Pressure rating</b> PN 10, 16, 25, 40 / Class 150, 300		
<b>Type of end connection • Flange</b> DIN EN 1092-1 / ANSI/ASME B16.5	<b>Type of end connection • Flangeless</b> DIN EN 1092-1	<b>Type of end connection • Flange</b> DIN EN 1092-1 / ANSI/ASME B16.5
<b>Seat/plug seal</b> Metal seal • Soft seal		
<b>Seat factors</b> F1 (100%) • F0,6 (60%) • F0,4 (40%) • F0,25 (25%)		
<b>Flow direction</b> Flow to close (FTC) • Flow to open (FTO)		
<b>Characteristic</b> Inherent • Equal percentage & linear (using a positioner) • On/off		
<b>Rangeability</b> Up to 200:1		
<b>Temperature range</b> -196 to +500 °C / -321 to +932 °F	<b>Temperature range</b> -100 to +500 °C / -148 to +932 °F	<b>Temperature range</b> -196 to +500 °C / -321 to +932 °F
<b>Leakage rate</b>	Metal seal: <b>IV</b> acc. to DIN EN 60354-4 and ANSI/FCI 70-2	
	Soft seal: <b>VI</b> acc. to DIN EN 60354-4 and ANSI/FCI 70-2	
<b>Compliance</b> CE, TSG		

**Table 3-2:** Valves for high pressure applications

Type 73.7	Type 73.3
	
<b>Face-to-face dimensions</b> DIN EN 558 R 2, 15, 39, 54	<b>Face-to-face dimensions</b> DIN EN 558 R 36
<b>Size</b> DN 25 to 500 / NPS 1 to 20	<b>Size</b> DN 25 to 250 / NPS 1 to 10
<b>Pressure rating</b> PN 63, 100, 160 / Class 600, 900, 1500*	
<b>Type of end connection • Flange</b> DIN EN 1092-1 / ANSI/ASME B16.5	
<b>Seat/plug seal</b> Metal seal • Soft seal	
<b>Seat factors</b> F1 (100%) • F0,6 (60%) • F0,4 (40%) • F0,25 (25%)	
<b>Flow direction</b> Flow to close (FTC) • Flow to open (FTO)	
<b>Characteristic</b> Inherent • Equal percentage & linear (using a positioner) • On/off	
<b>Rangeability</b> Up to 200:1	
<b>Temperature range</b> -196 to +500 °C / -321 to +932 °F	<b>Temperature range</b> -100 to +500 °C / -148 to +932 °F
<b>Leakage rate</b>	Metal seal: <b>IV</b> acc. to DIN EN 60354-4 and ANSI/FCI 70-2
	Soft seal: <b>VI</b> acc. to DIN EN 60354-4 and ANSI/FCI 70-2
<b>Compliance</b> CE, TSG	

\* Depending on valve size. Other pressure ratings on request.

**i Note**

Detailed technical information according to the data sheets (of the valve, actuator, etc.) and valve specification.

**Noise emissions**

SAMSON VETEC is unable to make general statements about noise emissions. The noise emissions depend on the valve version, plant facilities and process medium.

## 4 Shipment and on-site transport

The work described in this section is only to be performed by personnel appropriately qualified to carry out such tasks.

### 4.1 Accepting the delivered goods

After receiving the shipment, proceed as follows:

1. Check the scope of delivery. Check that the specifications on the valve nameplate match the specifications in the delivery note. See the 'Markings on the device' section for nameplate details.
2. Check the shipment for transportation damage. Report any damage to SAMSON VETEC and the forwarding agent (refer to delivery note).
3. Determine the weight and dimensions of the units to be lifted and transported in order to select the appropriate lifting equipment and lifting accessories, if required. Refer to the transport documents and the 'Technical data' section.

### 4.2 Removing the packaging from the valve

Observe the following sequence:

- Do not open or remove the packaging until immediately before lifting to install the valve into the pipeline.
- Leave the valve in its transport container or on the pallet to transport it on site.
- Do not remove the protective caps from the inlet and outlet until immediately before installing the valve into the pipeline. They prevent foreign particles from entering the valve.
- Dispose and recycle the packaging in accordance with the local regulations.

### 4.3 Transporting and lifting the valve

---

#### DANGER

**Danger due to suspended loads falling.**

- Stay clear of suspended or moving loads.
  - Close off and secure the transport paths.
- 

#### WARNING

**Risk of lifting equipment tipping over and risk of damage to lifting accessories due to exceeding the rated lifting capacity.**

- Only use approved lifting equipment and accessories whose minimum lifting capacity is higher than the weight of the valve (including actuator and packaging, if applicable).
-

---

**⚠ WARNING**

**Risk of personal injury due to the valve tipping over.**

- Observe the valve's centre of gravity.
  - Secure the valve against tipping over or turning.
- 
- 

**⚠ WARNING**

**Risk of injury due to incorrect lifting without the use of lifting equipment.**

Lifting the valve without the use of lifting equipment may lead to injuries (back injury in particular) depending on the weight of the valve.

- Observe the occupational health and safety regulations valid in the country of use.
- 
- 

**ⓘ NOTICE**

**Risk of valve damage due to incorrectly attached slings.**

The lifting eyelet/eyebolt on SAMSON VETEC actuators is only intended for mounting and removing the actuator as well as lifting the actuator without valve. Do not use this lashing point to lift the entire valve assembly.

- When lifting the valve, make sure that the slings attached to the valve body bear the entire load.
  - Do not attach load-bearing slings to the actuator, handwheel or any other parts.
  - Observe lifting instructions (see section 4.3.2).
- 
- 

**💡 Tip**

Our after-sales service can provide more detailed transport and lifting instructions on request.

---

---

**i Note**

Eye bolts and lifting equipment are not included in the scope of delivery.

---

---

**i Note**

The operator is responsible for selecting and fastening the ring bolts and lifting equipment.

---

---

### 4.3.1 Transporting the valve

The valve can be transported using lifting equipment (e.g. crane or forklift).

- ➔ Leave the valve in its transport container or on the pallet to transport it.
- ➔ Observe the transport instructions.

#### Transport instructions

- Protect the valve against external influences (e.g. impact).
- Do not damage the corrosion protection (paint, surface coatings). Repair any damage immediately.
- Protect the piping and any mounted valve accessories against damage.
- Protect the valve against moisture and dirt.
- The permissible transportation temperature of standard valves is –20 to +65 °C.

### 4.3.2 Lifting the valve

To install a large valve into the pipeline, use lifting equipment (e.g. crane or forklift) to lift it.

Lifting instructions

- Use a hook with safety latch to secure the slings from slipping off the hook during lifting and transporting.
- Secure slings against slipping.
- Make sure the slings can be removed from the valve once it has been installed into the pipeline.
- Prevent the valve from tilting or tipping over.
- Do not leave loads suspended when interrupting work for longer periods of time.

**To lift the valve, refer to the following documents:**

- Rotary plug valve with actuator Type R: ► **EB005.057**
- Rotary plug valve with actuator Type MD, MN and MZ: ► **EB005.036**

**Example for lifting the flanged valves Type 72.3, 73.3 and 73.7 with actuator Type R.**

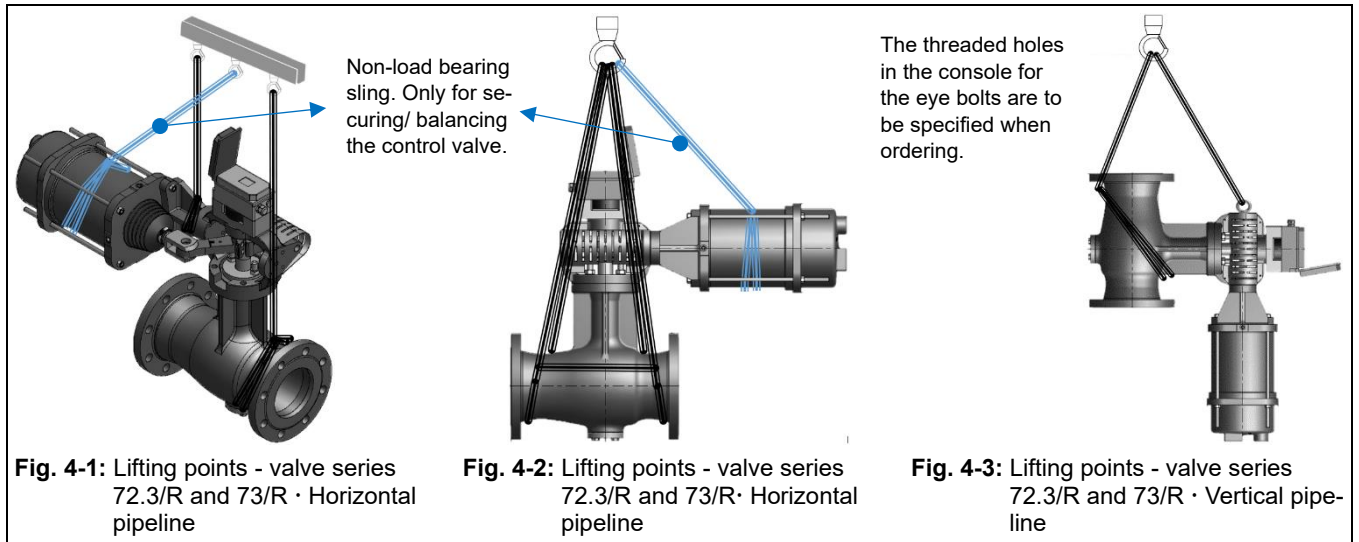

**Example for lifting the valves Type 72.4 (flangeless) with actuator Type R**

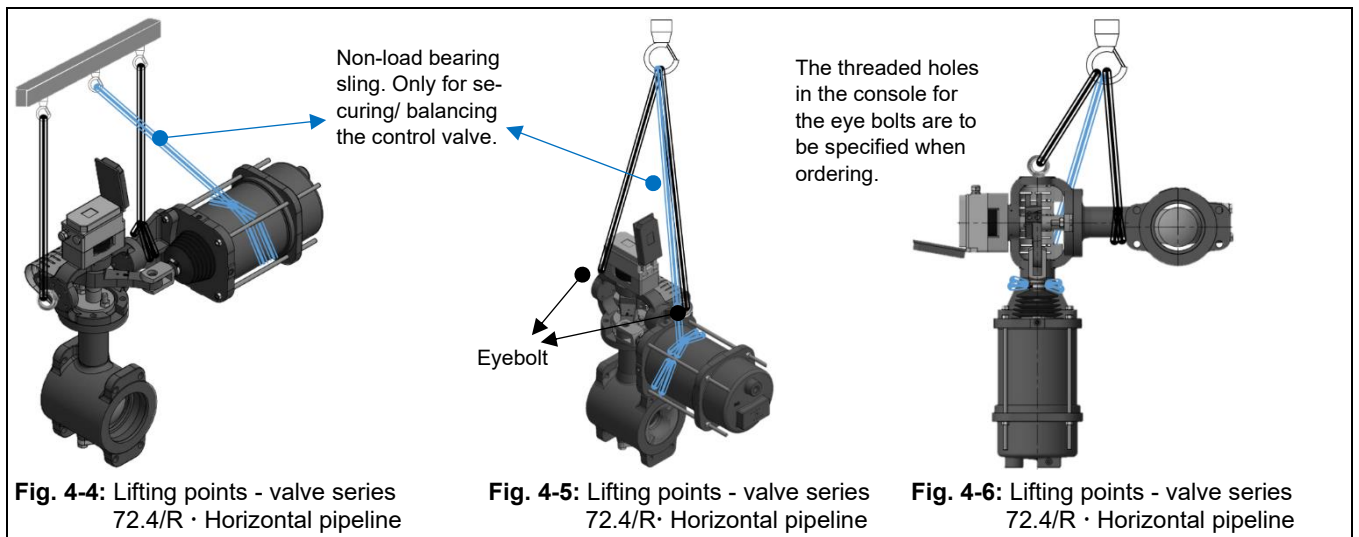

**Example for lifting the valves Type 82 with actuator Type R**

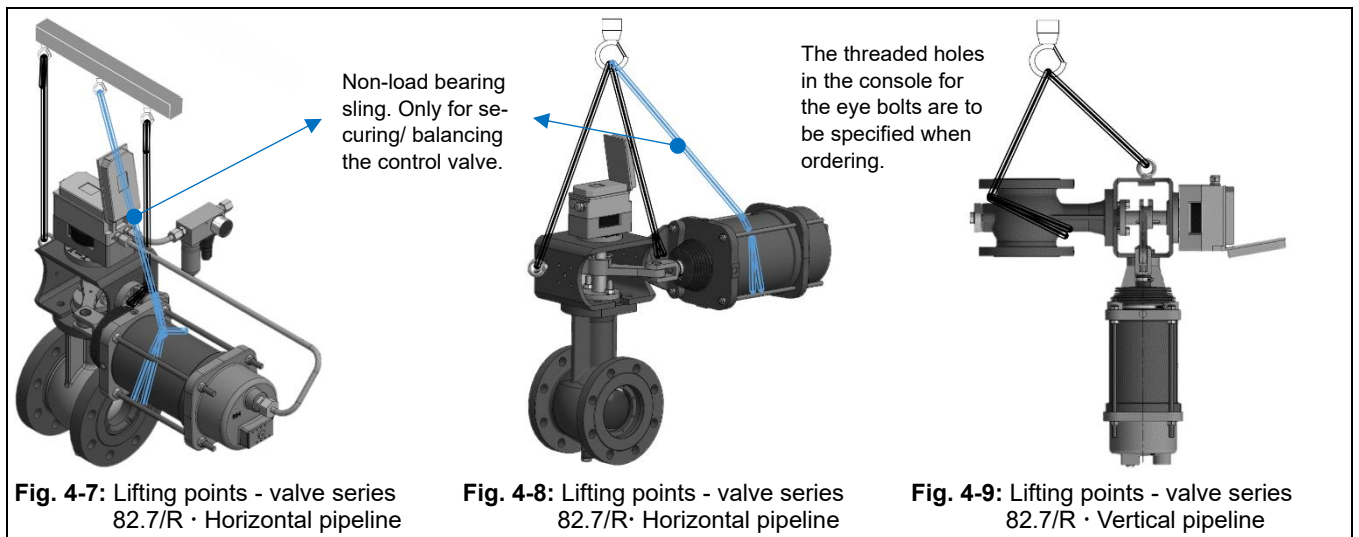

## Lifting the valves Type 72, 73, 82 with actuator Type MN

### NOTICE

#### Risk of actuator damage due to improper lifting.

Actuators Type MN may only be installed, transported (lifted) or stored in vertical positions (actuator facing upwards).

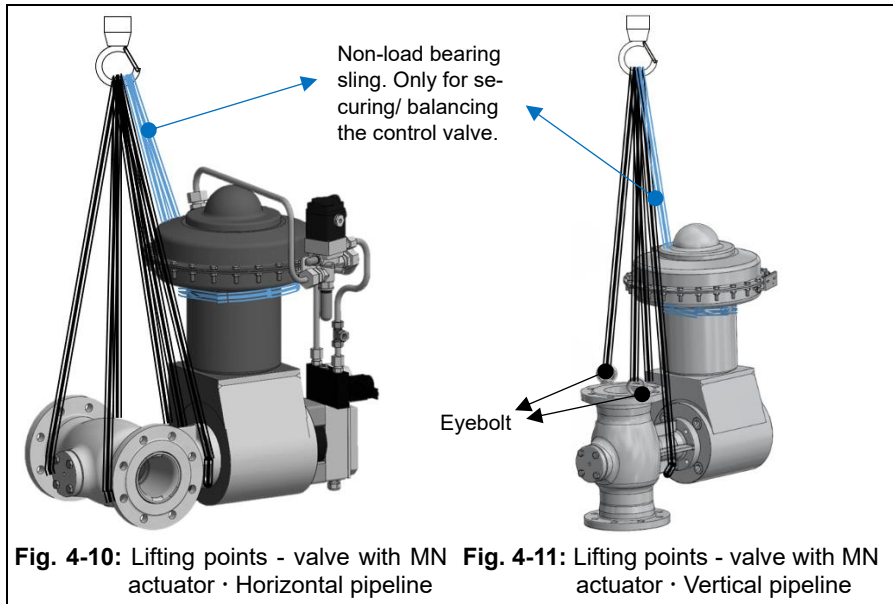

## Example for lifting the valves Type 72, 73, 82 with actuator Type MD and MZ

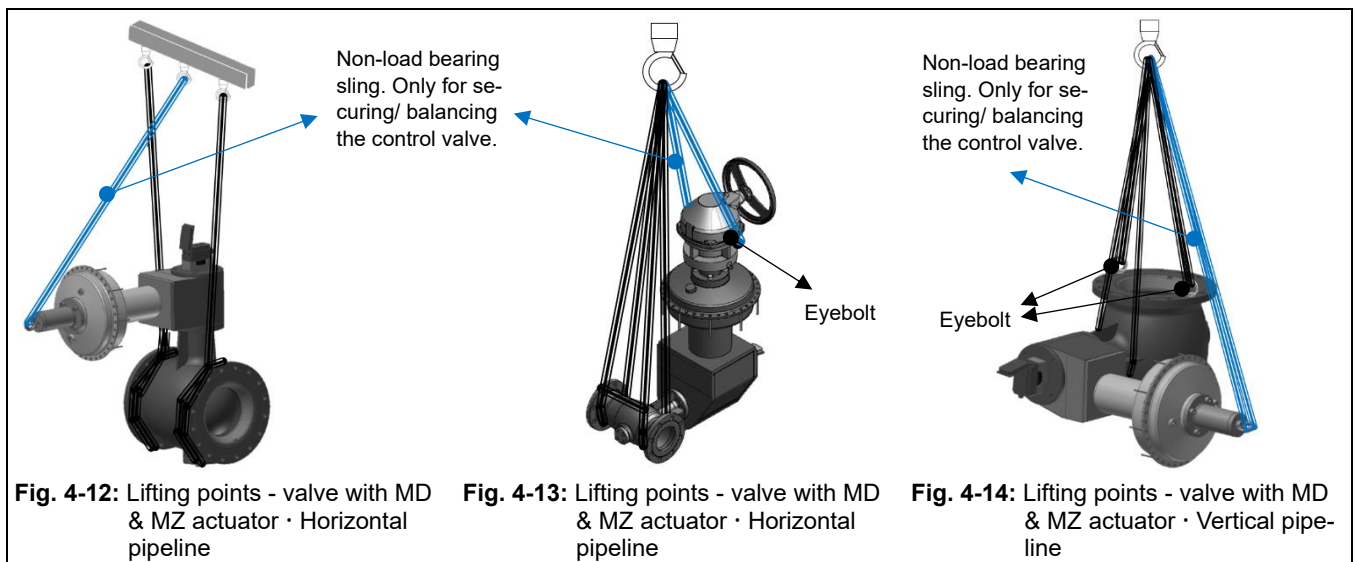

## 4.4 Storing the valve

---

### NOTICE

#### **Risk of valve damage due to improper storage.**

- ➔ Observe the storage instructions.
  - ➔ Avoid long storage times.
  - ➔ Contact SAMSON VETEC in case of different storage conditions or longer storage times.
  - ➔ Actuators Type MN may only be installed, transported (lifted) or stored in vertical positions (actuator facing upwards).
  - ➔ Observe the mounting and operating instructions for the accessories.
- 

#### **Storage instructions**

- Protect the valve against external influences (e.g. impact).
- Secure the valve in the stored position against slipping or tipping over.
- Do not damage the corrosion protection (paint, surface coatings). Repair any damage immediately.
- Protect the valve against moisture and dirt. Store it at a relative humidity of less than 75 %. In damp spaces, prevent condensation. If necessary, use a drying agent or heating.
- Make sure that the ambient air is free of acids or other corrosive media.
- The permissible storage temperature of standard valves is –20 to +65 °C. Contact our after-sales service for the storage temperatures of other valve versions.
- Do not place any objects on the valve.

Special storage instructions for elastomers

#### **Elastomer, e.g. actuator diaphragm**

- To keep elastomers in shape and to prevent cracking, do not bend them or hang them up.
- We recommend a storage temperature of 15 °C for elastomers.
- Store elastomers away from lubricants, chemicals, solutions, and fuels.

**For detailed information on storage, refer to ►EB005.045**

## 5 Installation

The work described in this section is only to be performed by personnel appropriately qualified to carry out such tasks.

### 5.1 Installation conditions

#### Work position

The work position for the valve is the front view looking onto the operating controls (including valve accessories).

Plant operators must ensure that, after installation of the device, the operating personnel can perform all necessary work safely and easily access the device from the work position.

#### Pipeline routing

The inlet and outlet lengths (see Table 5-1) vary depending on several variables and process conditions and are intended as recommendations.

To ensure that the valve functions properly, proceed as follows:

- Observe the inlet and outlet lengths (see Table 5-1).
- Install the valve free of stress and with the least number of vibrations as possible. Read information under 'Mounting position' and 'Support or suspension' in this section.
- Install the valve allowing sufficient space to remove the actuator and valve or to perform service and repair work on them.

**Table 5-1:** Inlet and outlet lengths

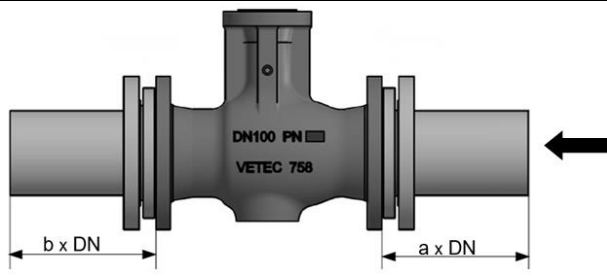

State of process medium	Valve conditions	Inlet length a	Outlet length b
Gas	$Ma \leq 0.3$	2	4
	$0.3 \leq Ma \leq 0.7$	2	10
Vapor	$Ma \leq 0.3$ <sup>1)</sup>	2	4
	$0.3 \leq Ma \leq 0.7$ <sup>1)</sup>	2	10
	Saturated steam (percentage of condensate > 5 %)	2	20
Liquid	Free of cavitation / $w < 10$ m/s	2	4
	Cavitation producing noise / $w \leq 3$ m/s	2	4
	Cavitation producing noise / $3 < w < 5$ m/s	2	10
	Critical cavitation / $w \leq 3$ m/s	2	10
	Critical cavitation / $3 < w < 5$ m/s	2	20
Flashing	-	2	20
Multi-phase	-	10	20

<sup>1)</sup> No saturated steam

## Mounting position

We recommend installing the valve with the actuator facing upwards: Type R-actuator with horizontal piston rod (parallel to the pipeline) and Type M-actuators with vertical piston rod (perpendicular to the pipeline). For other mounting positions contact After-sales service.

In the following versions/applications, the valve must be installed with the actuator on top:

- Valves with insulating section IT2
- Valves with actuator Type MN

**For all information on mounting position refer to ►TY005.071**

→ Contact SAMSON VETEC if the mounting positions are not as specified above.

## Valve accessories

→ During connection of valve accessories, make sure that they are easily accessible and can be operated safely from the work position.

## Vent plugs

Vent plugs are screwed into the exhaust airports of pneumatic and electropneumatic devices. They ensure that any exhaust air that forms can be vented to the atmosphere (to avoid excess pressure in the device). Furthermore, the vent plugs allow air intake to prevent a vacuum from forming in the device.

→ Locate the vent plug on the opposite side to the work position of operating personnel.

## Signal pressure line

When connecting the signal pressure line, ensure that the signal pressure corresponds to the design specifications. See the valve data on the nameplate or specification.

An insufficient cross-section of the supply signal pressure line or an insufficient signal pressure impair the valves' control response or proper functioning. An excessive supply pressure can damage the actuator and accessories.

### 5.1.1 Support or suspension of the valve in the pipeline

---

#### NOTICE

**Malfunction or risk of valve damage due to insufficient or incorrect support/suspension.**

- Observe the support points intended for this purpose.
  - Support the valve/actuator without stress or vibration.
  - Use sufficient and suitable supports or suspensions.
  - First support the pipeline, then support the valve and the actuator at the specified points.
- 
- 

#### Note

The plant engineering company is responsible for selecting and implementing a suitable support or suspension of the installed valve and the pipeline.

---

Depending on the valve version and mounting position, the valve, actuator, and pipeline must be supported or suspended.

In the following versions, the control valve must be supported or suspended with the appropriate support or suspension:

- Valves with actuators Type MD, MN, MZ
- For actuators weighing >50 kg
- For non-self-supporting pipelines

Refer to the following documents for all information on supporting the valve:

- Rotary plug valve with actuator Type MD: ►EB005.032
- Rotary plug valve with actuator Type MZ: ►EB005.031
- Rotary plug valve with actuator Type MN: ►EB005.xxx

## 5.2 Preparation for installation

---

### **WARNING**

**Risk due to incorrect handling valves for critical applications (such as oxygen, cryogenic gases, etc.)!**

- ➔ Make sure that the control valve is suitable for the application (materials, pressure, temperature, medium, lubricants, cleaning etc.). If there is any doubt about the suitability of the control valve for this application, contact SAMSON VETEC After-sales Service.
  - ➔ Use only clean tools.
  - ➔ The personnel must be sufficiently trained and informed about the hazards related to these applications.
- 

Before installation, make sure the following conditions are met:

- The valve is clean.
- The valve and all valve accessories (including piping) are not damaged.
- The valves from stock are checked for safety, function and tightness.
- The valve data on the nameplate (type designation, valve size, material, pressure rating and temperature range) match the plant conditions (size and pressure rating of the pipeline, medium temperature etc.). See the 'Markings on the device' section for nameplate details.
- The requested or required additional pipe fittings (see 'Additional fittings' in the 'Design and principle of operation' section) have been installed or prepared as necessary before installing the valve.
- The support or suspension of the valve (if applicable) is provided.
- The ground connection is provided. See Fig. 5-1.
- The insulation of the pipeline/valve is correctly sized. See Fig. 5-2 and 5-3.

### Ground (earth) connection

Electrostatic charges can build up on valve housings during plant operation. In the event of electrostatic discharge (ESD), this can lead to a risk of ignition of flammable gases, vapours, or dust in potentially explosive areas, as well as damage to electronic components.

Safety measures:

- ➔ Ground persons and equipment.
- ➔ Avoid electrostatic charges: clean equipment only with a damp cloth.



Fig. 5-1: Ground connection Valve Type 72, 73, 82

### Insulating the pipeline/valve

If insulation is required, observe the maximum insulation limit. Make sure no excessive temperatures or heat accumulation occur at the packing, O-rings, or seals.

**! NOTICE**

#### Risk of valve damage or malfunction due to incorrect insulation!

Excessive temperature can damage the O-rings/packing in the stuffing box, lead to increased leakage and malfunction of the valve.

- ➔ Do not exceed the permissible temperatures.
- ➔ Observe insulation limits. See Fig.5-2 and 5-3.
- ➔ Do not insulate valves mounted to comply with NACE MR0175 requirements and which have nuts and bolts that are not suitable for sour gas environments.

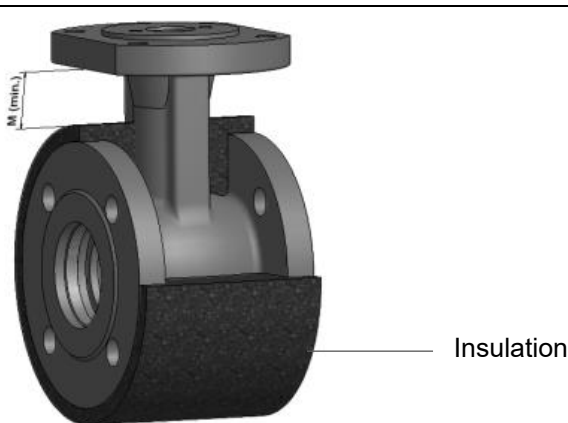
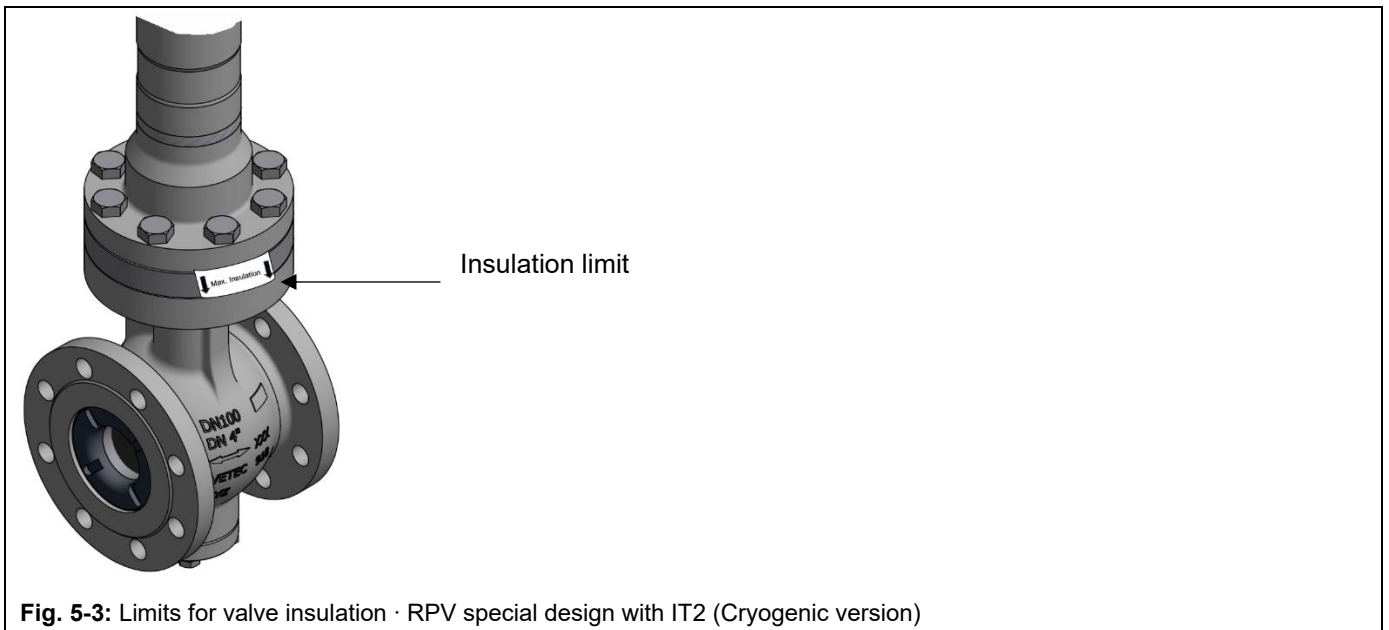

Fig. 5-2: Limits for valve insulation · RPV standard design

**Table 5-2:** Limit values for valve insulation

Valve Size	Distance M in mm
DN 25 / NPS 1	50
DN 40 / NPS 1½	60
DN 50 / NPS 2	60
DN 80 / NPS 3	60
DN 100 / NPS 4	60
DN 150 / NPS 6	100
DN 200 / NPS 8	100



**Valves with internal parts made of ceramic or hard metal (e.g. tungsten carbide)**

Valves with internal parts made of ceramic or tungsten carbide and their spare parts bear a special label. See Fig. 5-4.

- Do not expose valves / spare parts to sudden mechanical stress. For example, do not mount the actuator and accessories using impact movements.
- Do not expose valves / spare parts to shock-like temperatures. Observe the temperature shock limits.

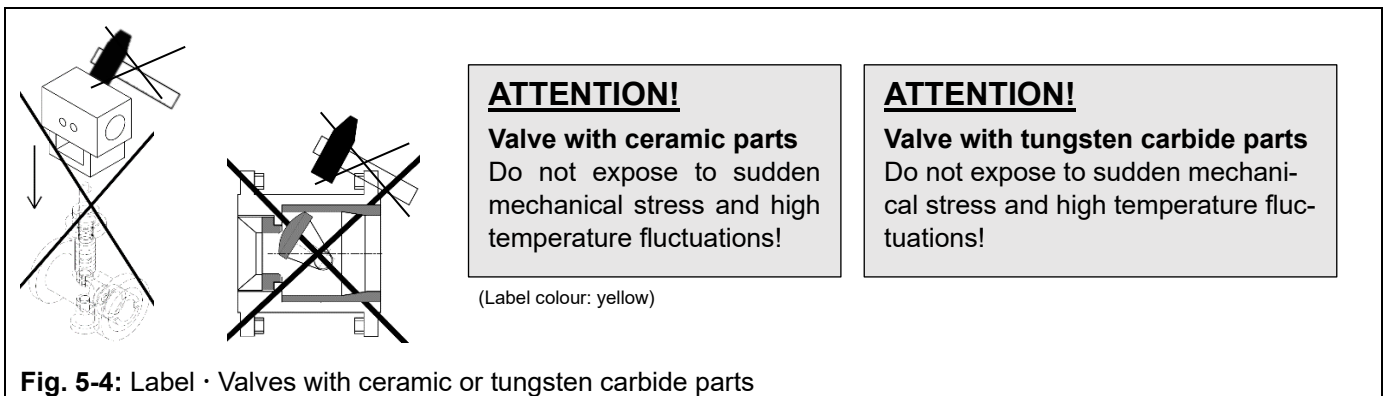

Valves such as type 72.2, 72.6 with retaining ring and ceramic / tungsten carbide parts are to be opened during installation in the pipeline. See Fig. 5-5.

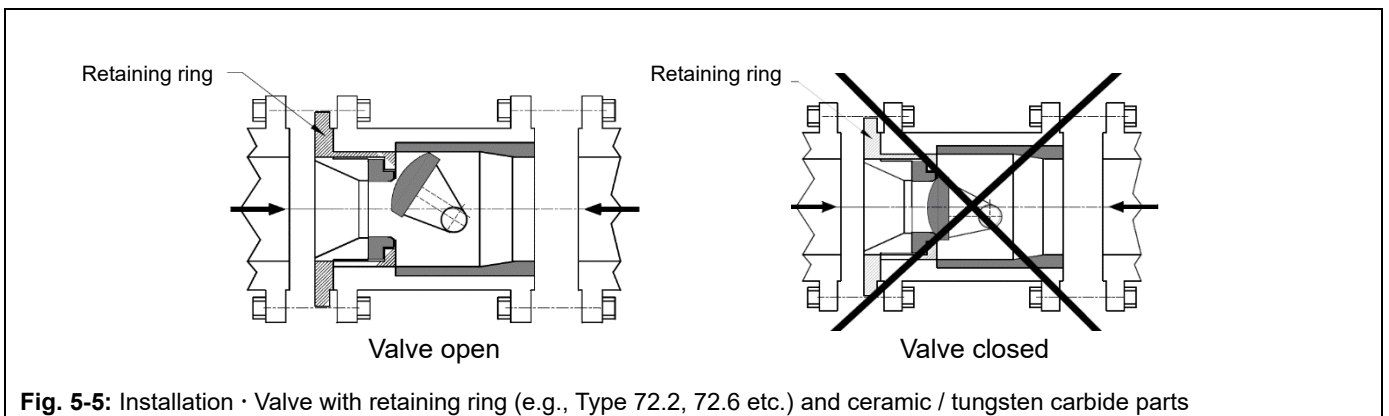

To ensure tightness to the atmosphere, cover the area between the armoured sleeve (e.g. made of ceramic or hard metal) and the valve body with the sealing surface of the pipeline flange. See Fig. 5-6 / Table 5-3.

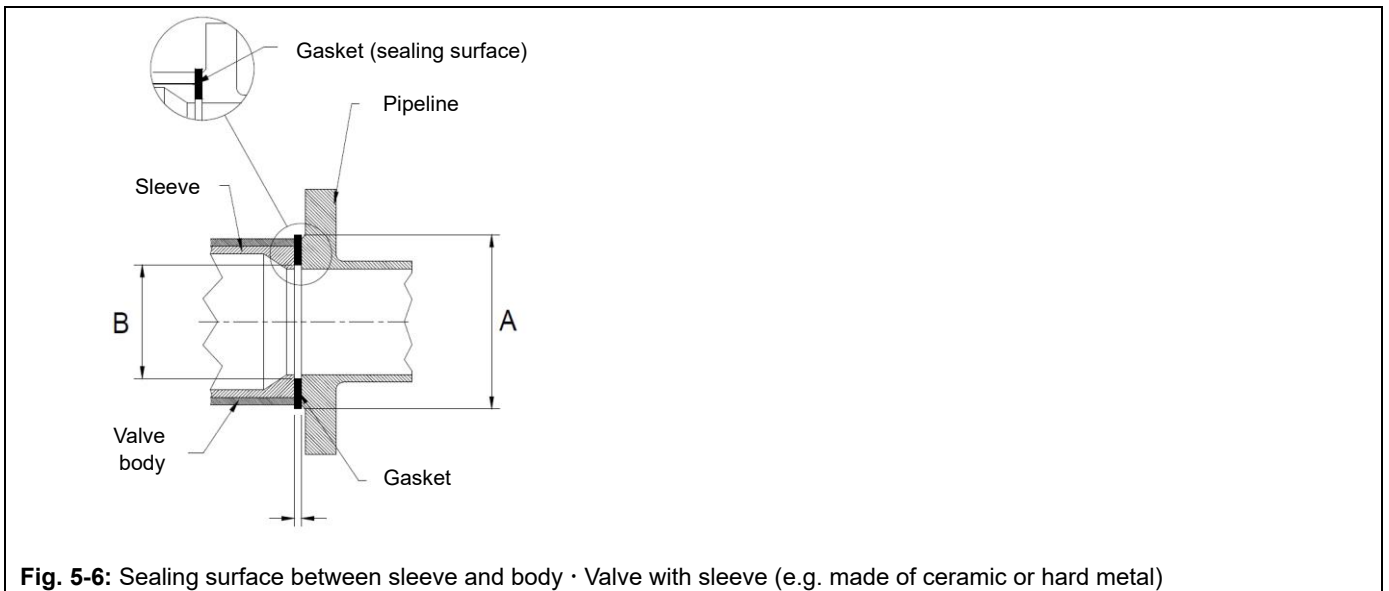

**Table 5-3:** Dimension A (Fig.5-6)

DN	NPS	A mm	B (Inside pipe dimensions acc. to Series 01) mm
25	1	64	28.5
40	1½	82	43.1
50	2	100	54.5
80	3	132	82.5
100	4	162	107.1
150	6	217	159.3
200	8	272	206.5
250	10	326	258.8
300	12	377	307.9

**For installation proceed as follows:**

- ➔ Lay out the necessary material and tools to have them ready during installation work.
- ➔ Flush the pipelines.

**i Note**

The plant operator is responsible for cleaning the pipelines in the plant.

- ➔ For steam applications, dry the pipelines. Moisture will damage the inside of the valve.
- ➔ Check any mounted pressure gauges to make sure they function properly.
- ➔ When the valve and actuator are already assembled, check the tightening torques of the bolted joints. Components may loosen during transport.

### 5.3 Mounting the device (actuator onto the valve)

SAMSON VETEC devices are delivered with the actuator already mounted on the valve. No assembly work is required.

### 5.4 Installing the valve into the pipeline

---

#### **! NOTICE**

##### **Risk of valve damage due to work being carried out by personnel not qualified for such tasks.**

- Maintenance and repair work, as well as assembly and operation, may only be carried out by qualified personnel who have been trained by SAMSON VETEC.
  - Contact VETEC after-sales-service [sales-vetec-de@samsongroup.com](mailto:sales-vetec-de@samsongroup.com).
- 

#### **! NOTICE**

##### **Risk of valve damage due to improper force impact!**

Control valve and attachments can be damaged by improper use of force.

- Not suitable as a stepping area.
  - Do not exert any improper force on the valve, actuator, and attachments.
  - Do not store the control valve on the control unit, actuator, and other attachments.
- 

#### **! NOTICE**

##### **Risk of valve damage due to incorrect direction of rotation!**

- Observe the direction of rotation of the control valve. Type 72, 73, 82 closing counterclockwise. Type 62 clockwise closing.
  - Stop the actuator immediately if the direction of rotation is incorrect.
  - Eliminate cause and repeat test run.
  - The associated documentation of the actuator is binding for the handling of the control valve.
- 

#### **! NOTICE**

##### **Risk of control valve damage due to incorrect insulation.**

- Do not exceed the permissible temperatures.
  - Do not exceed the specified insulation limits (See fig. 5-2 and 5-3).
  - Do not insulate valves mounted to comply with NACE MR0175 requirements and which have nuts and bolts that are not suitable for sour gas environments.
-

**! NOTICE**

**Risk of damage for valve with carbide housing due to improper mounting and sizing of the actuator!**

- Only mount the actuator after consultation with VETEC.
  - Do not use oversized actuators due to their own weight.
  - Do not use drives with fast closing function (short opening and closing times).
  - Do not open or close the control valve abruptly.
- 

**! NOTICE**

**Risk of damage for valve with carbide housing due to improper installation (alignment) in the pipeline!**

Non-parallelism of the flange sealing surfaces as well as uneven tightening of the pipe flanges can lead to stresses and thus to housing cracks.

- When installing the control valve and flanging the pipeline, make sure that no stresses are created.
  - Do not apply impact forces.
  - Align valve and pipe flanges in parallel.
  - Tighten pipe flanges evenly.
- 

**! NOTICE**

**Malfunction or risk of valve damage due to insufficient or incorrect support/suspension!**

- Observe the support points intended for this purpose.
  - Support the control valve/actuator without stress or vibration.
  - Use sufficient and suitable supports or suspensions.
- 

1. Close the shut-off valves in the pipeline at the inlet and outlet of the plant section while the valve is being installed.
2. Prepare the relevant section of the pipeline for installing the valve.
3. Remove the protective caps from the valve ports before installing the valve.
4. Lift the valve using suitable lifting equipment to the site of installation (see information under 'Lifting the valve' in the 'Shipment and on-site transport' section).
5. Observe the flow direction through the valve. The arrow on the valve indicates the direction of flow.
6. Make sure that the correct flange gaskets are used.
7. Bolt the pipe to the valve free of stress.
8. Attach a support or suspension on the valve.
9. Earth the valve.

### 5.4.1 Installing the valve Type 72.4 (Wafer lug) into the pipeline

Installation kits (tie rods/bolts) are required to install the flangeless valves type 72.4 in the pipeline. See Table 5-4.

When using different thread versions, the bolt dimensions remain unchanged, only the thread version changes (e.g., ANSI - UNC).

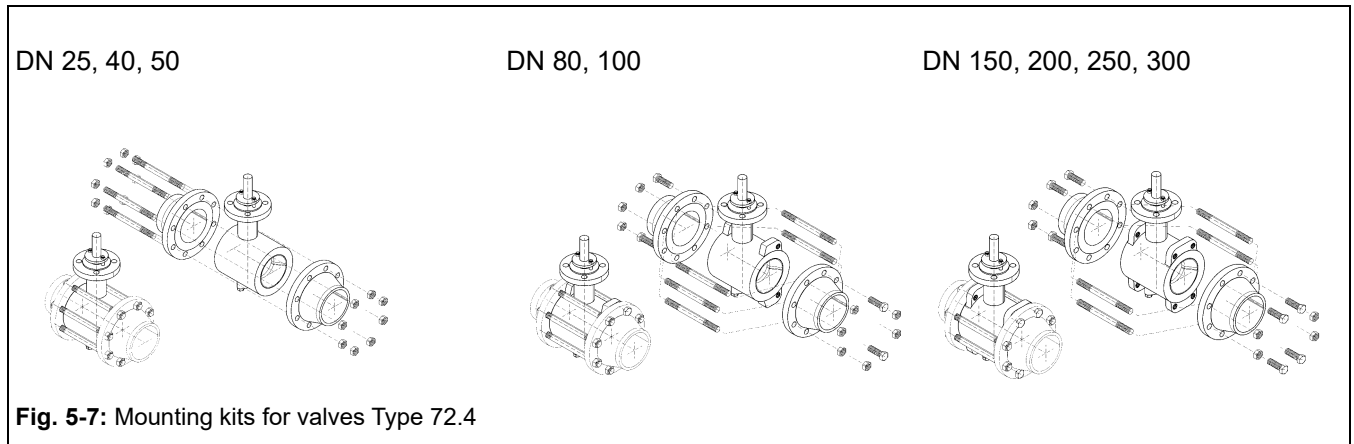

**Table 5-4:** Mounting kits for installation

Nominal size	Pressure rating	Tie rod with 2 nuts each		Bolts	
		Pcs.	Dimensions	Pcs.	Dimensions
DN 25	PN 10	4	M12x180		
DN 25	PN 16	4	M12x180		
DN 25	PN 25	4	M12x180		
DN 25	PN 40	4	M12x180		
DN 40	PN 10	4	M16x200		
DN 40	PN 16	4	M16x200		
DN 40	PN 25	4	M16x200		
DN 40	PN 40	4	M16x200		
DN 50	PN 10	4	M16x210		
DN 50	PN 16	4	M16x210		
DN 50	PN 25	4	M16x210		
DN 50	PN 40	4	M16x210		
DN 80	PN 10	6	M16x260	4	M16x35
DN 80	PN 16	6	M16x260	4	M16x35
DN 80	PN 25	6	M16x260	4	M16x40
DN 80	PN 40	6	M16x260	4	M16x40
DN 100	PN 10	6	M16x285	4	M16x50
DN 100	PN 16	6	M16x285	4	M16x50
DN 100	PN 25	6	M20x300	4	M20x55
DN 100	PN 40	6	M20x300	4	M20x55
DN 150	PN 10	4	M20x330	8	M20x55
DN 150	PN 16	4	M20x330	8	M20x55
DN 150	PN 25	4	M24x350	8	M24x60

DN 150	PN 40	4	M24x350	8	M24x60
DN 200	PN 10	4	M20x350	8	M20x55
DN 200	PN 16	8	M20x350	8	M20x55
DN 200	PN 25	8	M24x370	8	M24x65
DN 200	PN 40	8	M27x385	8	M27x65
DN 250	PN 10	8	M20x410	8	M20x70
DN 250	PN 16	8	M24x420	8	M24x70
DN 250	PN 25	8	M27x440	8	M27x75
DN 250	PN 40	8	M30x460	8	M30x80
DN 300	PN 10	8	M20x450	8	M20x70
DN 300	PN 16	8	M24x470	8	M24x70
DN 300	PN 25	12	M27x490	8	M27x75
DN 300	PN 40	12	M30x510	8	M30x85

## 5.5 Testing the installed valve

### DANGER

#### Risk of bursting due to incorrect opening of pressurized equipment or components.

Valves and pipelines are pressure equipment that may burst when handled incorrectly. Flying projectile fragments or the release of process medium under pressure can cause serious injury or even death.

Before working on the control valve:

- Observe the maximum permissible pressure for valve and plant
- Depressurize all plant sections affected and the valve (including the actuator). Release any stored energy.
- Drain the process medium from all the plant sections concerned as well as the valve.

### WARNING

#### Risk of personal injury due to pressurized components and process medium being discharged!

- Do not loosen external pressure-bearing components (e.g. screw of the test connection; screw for the shaft blow-out protection (101) for valve Types 72 and 73) while the valve is in operation. See Fig. 7-1, 7-2.

### WARNING

#### Risk of hearing loss or deafness due to loud noise.

Noise emission (e.g. cavitation or flashing) may occur during operation caused by the process medium and the operating conditions. Additionally, a loud noise may briefly occur through the sudden venting of the pneumatic actuator or pneumatic valve accessories not fitted with noise-reducing fittings. Both can damage hearing.

- Wear hearing protection when working near the valve.
- Use suitable noise-reducing fittings.

---

**⚠ WARNING**

**Crush hazard arising from moving parts.**

The valve contains moving parts (actuator piston rod/lever and valve shaft), which can injure hands or fingers if inserted into the valve.

- Do not insert hands or finger into the bracket while the air supply is connected to the actuator.
  - Before working on the valve, disconnect and lock the pneumatic air supply as well as the control signal.
  - Do not impede the movement of the actuator piston rod/lever and valve shaft by clamping objects.
  - Before unblocking the actuator piston rod and valve shaft after they have become blocked (e.g., due to seizing up after remaining in the same position for a long time), release any stored energy in the actuator (e.g., spring compression). See associated actuator documentation.
- 

**⚠ WARNING**

**Risk of personal injury due to exhaust air being vented.**

While the valve is operating, air is vented from the actuator, for example, during closed-loop operation or when the valve opens or closes.

- Wear eye protection when working in close proximity to the control valve.
- 

**⚠ WARNING**

**Risk of personal injury due to preloaded springs.**

Actuators with preloaded springs are under tension.

- Before starting any work on the actuator, relieve the compression from the preloaded springs (see associated actuator documentation).
- 

To test the valve functioning before start-up or putting back the valve into operation, perform the following tests:

### 5.5.1 Leak test

The plant operator is responsible for performing the leak test and selecting the test method. The leak test must comply with the requirements of the national and international standards that apply at the site of installation.

1. Close the valve.
2. Slowly apply the test medium to the inlet space upstream of the valve. A sudden surge in pressure and resulting high flow velocities can damage the valve.
3. Open the valve.
4. Apply the required test pressure.
5. Check the valve for leakage to the atmosphere.
6. Depressurize the pipeline section and valve.
7. Rework any parts that leak (see information below under 'Adjusting the packing') and repeat the leak test.

## Adjusting the packing

A label on the valve/actuator indicates whether an adjustable packing is installed (see the 'Markings on the device').

---

### NOTICE

**Impaired valve functioning due to increased friction as a result of the stuffing box being tightened too far.**

→ Make sure that the plug shaft can still move smoothly after the bushing has been tightened.

---

1. Tighten the stuffing box gradually until the packing seals the valve.
  2. Open and close the valve several times.
  3. Check the valve for leakage to the atmosphere.
  4. Repeat steps 1 and 2 until the packing completely seals the valve.
- If the adjustable packing does not seal properly, contact our after-sales service.

## 5.5.2 Rotary motion

The movement of the actuator piston rod / lever must be smooth.

- Apply the maximum and minimum control signals to check the end positions of the valve while observing the movement of the actuator piston rod / shaft lever.
- Check the rotation of the shaft on the indicator scale.

## 5.5.3 Fail-safe position

- Shut off the signal pressure line.
- Check whether the valve moves to the fail-safe position (see the 'Design and principle of operation' section).

## 5.5.4 Pressure test

The plant operator is responsible for performing the pressure test.

During the pressure test, make sure the following conditions are met:

- Rotate the plug shaft to open the valve.
- Observe the maximum permissible pressure for both the valve and plant.

## 6 Start-up

The work described in this section is only to be performed by personnel appropriately qualified to carry out such tasks.

---

### **WARNING**

#### **Risk of burn injuries due to hot or cold components and pipeline.**

Valve components and the pipeline may become very hot or cold. Risk of burn injuries.

- Allow components and pipelines to cool down or warm up to the ambient temperature.
  - Wear protective clothing and safety gloves.
- 

### **WARNING**

#### **Risk of personal injury due to pressurized components and process medium being discharged.**

- Do not loosen external pressure-bearing components (e.g. screw of the test connection; screw for the shaft blow-out protection (101) for valve Types 72 and 73) while the valve is in operation. See Fig. 7-1, 7-2.
- 

### **WARNING**

#### **Risk of hearing loss or deafness due to loud noise.**

Noise emission (e.g. cavitation or flashing) may occur during operation caused by the process medium and the operating conditions. Additionally, a loud noise may briefly occur through the sudden venting of the pneumatic actuator or pneumatic valve accessories not fitted with noise-reducing fittings. Both can damage hearing.

- Wear hearing protection when working near the valve
  - Use suitable noise-reducing fittings.
- 

### **WARNING**

#### **Crush hazard arising from moving parts.**

The valve contains moving parts (actuator piston rod/lever and valve shaft), which can injure hands or fingers if inserted into the valve.

- Do not insert hands or finger into the bracket while the air supply is connected to the actuator.
  - Before working on the valve, disconnect and lock the pneumatic air supply as well as the control signal.
  - Do not impede the movement of the actuator piston rod/lever and valve shaft by clamping objects.
  - Before unblocking the actuator piston rod and valve shaft after they have become blocked (e.g., due to seizing up after remaining in the same position for a long time), release any stored energy in the actuator (e.g., spring compression). See associated actuator documentation.
-

## ⚠ WARNING

### Risk of personal injury due to exhaust air being vented.

While the valve is operating, air is vented from the actuator, for example, during closed-loop operation or when the valve opens or closes.

→ Wear eye protection when working in close proximity to the control valve.

Before start-up or putting the valve back into service, make sure the following conditions are met:

- The valve is properly installed into the pipeline (see the 'Installation' section).
- The leak and function tests have been completed successfully (see 'Testing the installed valve' in the 'Installation' section).
- The prevailing conditions in the plant section concerned meet the valve sizing requirements (see information under 'Intended use' in the 'Safety instructions and measures' section).

### Start-up/putting the valve back into operation

1. Allow the valve to cool down or warm up to reach ambient temperature before start-up when the ambient temperature and process medium temperature differ greatly, or the medium properties require such a measure.
2. Slowly open the shut-off valves in the pipeline. Slowly opening these valves prevents a sudden surge in pressure and high flow velocities which can damage the valve.
3. Check the valve to ensure it functions properly.

### Valves with longer heating-up time

For valves from DN 200 and at operating temperatures above 200 °C, expansion of the components due to temperature rise cannot be avoided.

During the heating phase, the heat is distributed unevenly across the valve due to the different materials and design. The components expand differently. As a result, the plug can jam in the seat ring. See Fig.6-1.

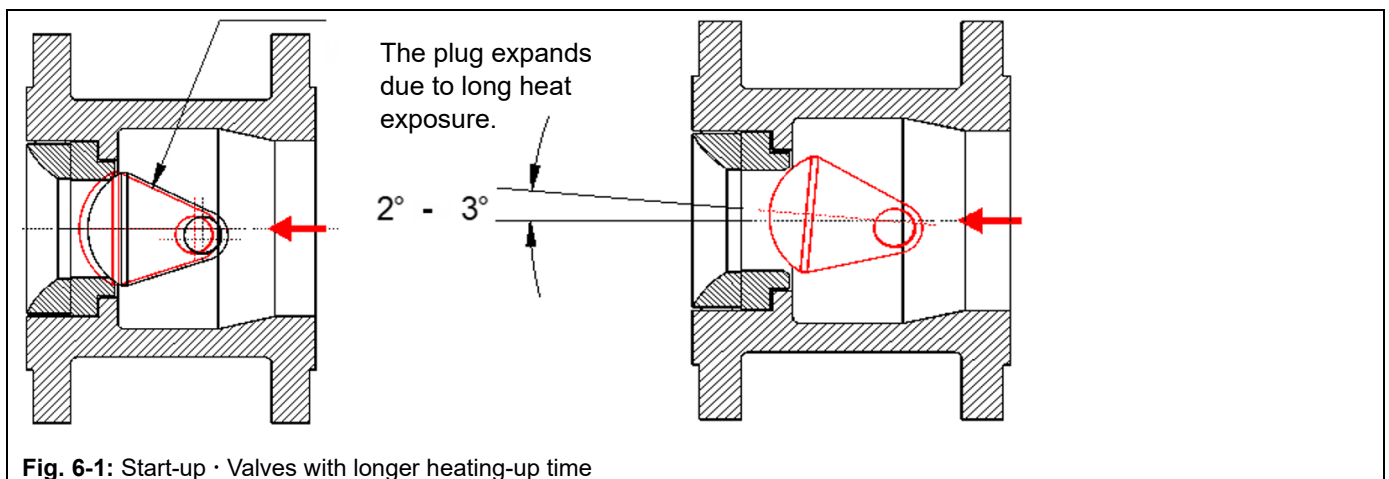

Fig. 6-1: Start-up · Valves with longer heating-up time

Proceed as follows to prevent the plug from jamming:

1. Open the valve slightly (opening angle of approx. 2° to 3°) before starting commissioning. The valve can be opened by the specified angle using the actuator or additionally mounted travel stops on the actuator.
2. Close the plug after start-up when the process medium has distributed the heat evenly.

## 7 Operation

Immediately after completing start-up or putting the valve back into operation, the valve is ready for use.

The control valves, as parts of the plant, are to be operated according to the operator's instructions and regulations. Unstable control causes increased wear. Contaminated supply power or auxiliary energy and signals not according to specifications can cause the accessories or the entire control valve to malfunction or fail.

Protect the valves against impermissible internal or external stress during operation.

---

### WARNING

#### **Risk of burn injuries due to hot or cold components and pipeline.**

Valve components and the pipeline may become very hot or cold. Risk of burn injuries.

- Allow components and pipelines to cool down or warm up to the ambient temperature.
  - Wear protective clothing and safety gloves.
- 

### WARNING

#### **Risk of personal injury due to pressurized components and process medium being discharged.**

- Do not loosen external pressure-bearing components (e.g. screw of the test connection; screw for the shaft blow-out protection (101) for valve Types 72 and 73) while the valve is in operation. See Fig. 7-1, 7-2.
- 

### WARNING

#### **Risk of hearing loss or deafness due to loud noise.**

Noise emission (e.g. cavitation or flashing) may occur during operation caused by the process medium and the operating conditions. Additionally, a loud noise may briefly occur through the sudden venting of the pneumatic actuator or pneumatic valve accessories not fitted with noise-reducing fittings. Both can damage hearing.

- Wear hearing protection when working near the valve
- 

### WARNING

#### **Crush hazard arising from moving parts.**

The valve contains moving parts (actuator piston rod/lever and valve shaft), which can injure hands or fingers if inserted into the valve.

- Do not insert hands or finger into the bracket while the air supply is connected to the actuator.
  - Before working on the valve, disconnect and lock the pneumatic air supply as well as the control signal.
  - Do not impede the movement of the actuator piston rod/lever and valve shaft by clamping objects.
  - Before unblocking the actuator piston rod and valve shaft after they have become blocked (e.g., due to seizing up after remaining in the same position for a long time), release any stored energy in the actuator (e.g., spring compression). See associated actuator documentation.
-

**⚠ WARNING**

**Risk of personal injury due to exhaust air being vented.**

While the valve is operating, air is vented from the actuator, for example, during closed-loop operation or when the valve opens or closes.

- ➔ Wear eye protection when working in close proximity to the control valve.

**⚠ NOTICE**

**Malfunction of the control valve due to prolonged non-operation!**

- ➔ Check the function and fail-safe action of the valve at regular intervals.

**💡 Tip**

We recommend the use of SAMSON positioner with integrated diagnostic firmware for valves used for on/off service. The partial stroke test included in this software helps prevent a shut-off valve normally in its end position from seizing up or getting jammed.

The lateral screw (101) is not a port sniffer. It serves as a blow out for the shaft and must not be removed during the operation. See Fig. 7-2.

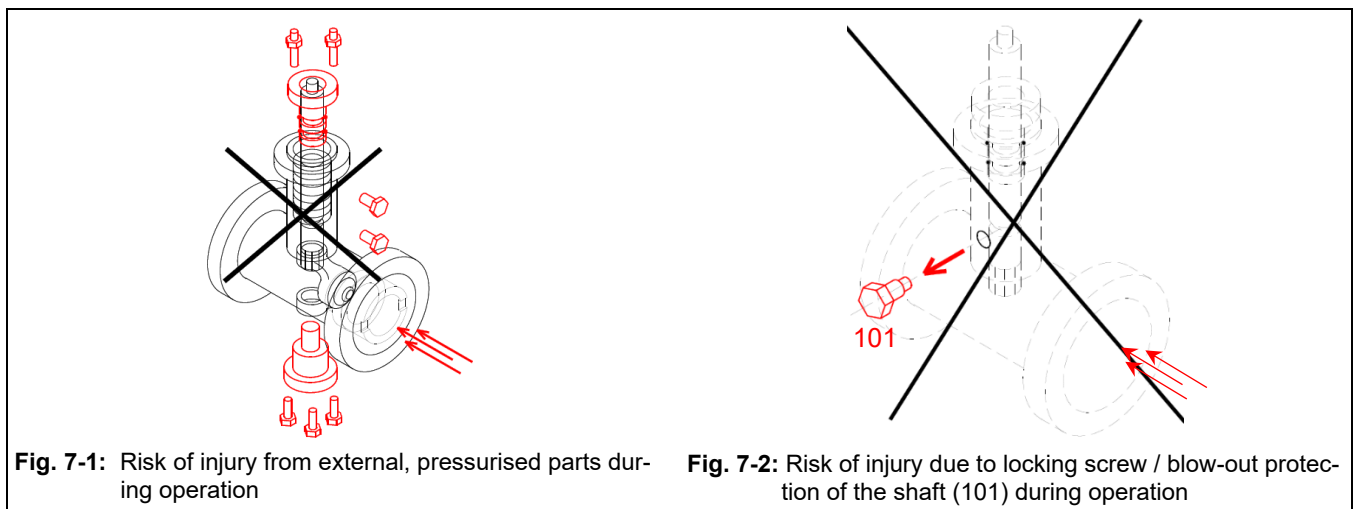

**7.1 Normal operation**

The handwheel of valves with actuators fitted with a handwheel must be in the neutral position during normal operation. See associated documentation of the handwheel.

**7.2 Manual operation**

Valves with actuators fitted with a handwheel can be manually closed or opened in the event of failure of the auxiliary energy supply. See associated gearbox documentation.

## 8 Malfunctions

Read hazard statements, warnings, and caution notes in the 'Safety instructions and measures' section.

### 8.1 Troubleshooting

Table 8-1

Malfunction	Possible reasons	Recommended action
Actuator piston rod/lever and shaft do not move on demand.	Actuator is blocked.	Check attachment. Remove the blockage. <b>WARNING!</b> A blocked actuator piston rod or shaft (e.g. due to seizing up after remaining in the same position for a long time) can suddenly start to move uncontrollably. Injury to hands or fingers is possible if they are inserted into the actuator or valve. Before trying to unblock the actuator or shaft, disconnect and lock the pneumatic air supply as well as the control signal. Before unblocking the actuator, release any stored energy in the actuator (e.g. spring compression). See associated actuator documentation.
	Diaphragm in the actuator defective	See associated actuator documentation.
	Signal pressure too low	Check the signal pressure. Check the signal pressure line for leakage.
Jolting movement of the actuator piston rod/lever and shaft	Version with adjustable packing: stuffing box tightened too far	Tighten the packing correctly (see information under 'Adjusting the packing' in the 'Leak test 5.5.1' section > 'Testing the installed valve').
Lever and shaft do not move over the entire rotation angle	Signal pressure too low	Check the signal pressure. Check the signal pressure line for leakage.
	Incorrect setting of valve accessories	Check the settings of the valve accessories.
Increased flow through closed valve (seat leakage)	Dirt or other foreign particles deposited between the seat and plug.	Shut off the section of the pipeline and flush the valve.
	Valve seat/plug, particularly with soft seat, is worn.	Replace seat and plug (see the 'Servicing/Repairs' section) or contact our after-sales service.
The valve leaks to the atmosphere (fugitive emissions).	Defective packing	Replace packing (see the 'Servicing' section) or contact our after-sales service.
	Version with adjustable packing: stuffing box not tightened correctly	Adjust the packing (see information under 'Adjusting the packing' in the 'Leak test 5.5.1' section > 'Testing the installed valve'). Contact our after-sales service when it continues to leak.
	Threaded flanged joint loosened or gasket damaged	Check the flanged joint. Replace gasket at the flanged joint.

#### **i** Note

Contact our after-sales service for malfunctions not listed in the table.

## 8.2 Emergency action

Plant operators are responsible for emergency action to be taken in the plant.

In the event of a valve malfunction:

1. Close the shut-off valves upstream and downstream of the control valve to stop the process medium from flowing through the valve.
2. Perform troubleshooting (see section 8.1).
3. Rectify those malfunctions that can be remedied based on the instructions provided here. Contact our after-sales service in all other cases.

### **Putting the valve back into operation after a malfunction**

See the 'Start-up' section.

## 9 Servicing

The work described in this section is only to be performed by personnel appropriately qualified to carry out such tasks.

The following documents are also required for servicing the valve:

- Mounting and operating instructions for the mounted actuator
- Maintenance instructions of the valve. Contact our after-sales service.
- Tools, tightening torques

---

### DANGER

#### **Risk of bursting due to incorrect opening of pressurized equipment or components.**

Valves and pipelines are pressure equipment that may burst when handled incorrectly. Flying projectile fragments or the release of process medium under pressure can cause serious injury or even death.

Before working on the control valve:

- Observe the maximum permissible pressure for valve and plant.
- Depressurize all plant sections affected and the valve including the actuator. Release any stored energy.
- Drain the process medium from all the plant sections concerned as well as the valve.

---

### WARNING

#### **Risk of burn injuries due to hot or cold components and pipeline.**

Valve components and the pipeline may become very hot or cold. Risk of burn injuries.

- Allow components and pipelines to cool down or warm up to the ambient temperature.
- Wear protective clothing and safety gloves.

---

### WARNING

#### **Risk of personal injury due to pressurized components and process medium being discharged.**

- Do not loosen external pressurised parts (e.g. test connection, shaft blow-out protection screw (101) for valve types 72 and 73) while the valve is pressurised. See Fig. 7-1, 7-2.

---

### WARNING

#### **Risk of hearing loss or deafness due to loud noise.**

Noise emission (e.g. cavitation or flashing) may occur during operation caused by the process medium and the operating conditions. Additionally, a loud noise may briefly occur through the sudden venting of the pneumatic actuator or pneumatic valve accessories not fitted with noise-reducing fittings. Both can damage hearing.

- Wear hearing protection when working near the valve

---

**⚠ WARNING**

**Crush hazard arising from moving parts.**

The valve contains moving parts (actuator piston rod/lever and valve shaft), which can injure hands or fingers if inserted into the valve.

- Do not insert hands or finger into the bracket while the air supply is connected to the actuator.
  - Before working on the valve, disconnect and lock the pneumatic air supply as well as the control signal.
  - Do not impede the movement of the actuator piston rod/lever and valve shaft by clamping objects.
  - Before unblocking the actuator piston rod and valve shaft after they have become blocked (e.g., due to seizing up after remaining in the same position for a long time), release any stored energy in the actuator (e.g., spring compression). See associated actuator documentation.
- 

**⚠ WARNING**

**Risk of personal injury due to exhaust air being vented.**

While the valve is operating, air is vented from the actuator, for example, during closed-loop operation or when the valve opens or closes.

- Wear eye protection when working in close proximity to the control valve.
- 

**⚠ WARNING**

**Risk of personal injury due to preloaded springs.**

Actuators with preloaded springs are under tension.

- Before starting any work on the actuator, relieve the compression from the preloaded springs (see associated actuator documentation).
- 

**⚠ WARNING**

**Risk of personal injury due to residual process medium in the valve.**

While working on the valve, residual medium can flow out of the valve and, depending on its properties, cause personal injury, e.g. (chemical) burns

- Wear protective clothing, safety gloves, respiratory protection and eye protection.
-

---

**! NOTICE**

**Risk of valve damage due to excessively high or low tightening torques.**

Observe the specified torques when tightening control valve components. Excessive tightening torques lead to parts wearing out more quickly. Parts that are too loose may cause leakage.

- Observe the specified tightening torques.
- 

**! NOTICE**

**Risk of valve damage due to the use of unsuitable tools.**

- Only use tools that are suitable and tested for this purpose.
  - Special tools from VETEC on request: [sales-vetec-de@samsongroup.com](mailto:sales-vetec-de@samsongroup.com)
- 

**! NOTICE**

**Risk of valve damage due to the use of unsuitable lubricants.**

- Only use approved lubricants that have been tested for pressure, temperature and media resistance.
- 

**! NOTICE**

**Risk of the process medium being contaminated through the use of unsuitable lubricants and/or contaminated tools and components.**

- If necessary (e.g. for oxygen service), keep the valve and the tools used free from solvents and grease.
  - Make sure that only suitable lubricants are used that have been tested for pressure, temperature, and media compatibility.
  - For critical applications (e.g. oxygen) follow the cleaning instructions. Ensure cleanliness in accordance with standards.
- 

**i Note**

The control valve was checked by SAMSON VETEC before it left the factory.

- Certain test results certified by SAMSON VETEC lose their validity when the valve is opened. Such testing includes seat leakage and leak tests.
  - The product warranty becomes void if any service/repair work is carried out on the device (valve, actuator, accessories).
  - Only use original spare parts by SAMSON VETEC, which comply with the original specifications.
-

## 9.1 Periodic testing

Depending on the operating conditions, check the valve at certain intervals to prevent possible failure before it can occur. Plant operators are responsible for drawing up an inspection and test plan.

SAMSON VETEC recommends the following inspection and testing which can be performed while the process is running:

Inspection and testing	Action to be taken in the event of a negative result
Check the markings, labels and nameplates on the valve for their readability and completeness.	Immediately renew damaged, missing or incorrect nameplates or labels.
	Clean any inscriptions that are covered with dirt and are illegible.
Check the pipe connections and gaskets on the valve and actuator for leakage.	Check the bolted joint (tightening torque).
	Replace the gaskets. See Maintenance instructions.
	Version with adjustable packing: adjust the packing (see information under 'Adjusting the packing' in the 'Installation' section 5.5 'Testing the installed valve') or replace the packing (see maintenance instructions).
Check the internal tightness of the valve (seat leakage).	Shut off the section of the pipeline and flush the valve to remove any dirt and/or deposited foreign particles between the seat and plug.
	Replace seat and plug. See maintenance instructions.
Check the valve for external damage (e.g. corrosion).	Repair any damage immediately. If necessary, put the control valve out of operation (see the 'Decommissioning' section).
Check the valve accessories to ensure they are mounted properly.	Tighten the connections of the valve accessories.
Check to ensure that the actuator piston rod and valve shaft move smoothly.	Version with adjustable packing: tighten the packing correctly (see information under 'Adjusting the packing' in the 'Leak test 5.5.1' section 'Testing the installed valve').
	Unblock a blocked actuator piston rod/lever and valve shaft. <b>WARNING!</b> A blocked actuator or valve shaft (e.g. due to seizing up after remaining in the same position for a long time) can suddenly start to move uncontrollably. Injury to hands or fingers is possible if they are inserted into the actuator or valve. Before trying to unblock the actuator or valve shaft, disconnect and lock the pneumatic air supply as well as the control signal. Before unblocking the actuator, release any stored energy in the actuator (e.g. spring compression). See associated actuator documentation.
If possible, check the valve's fail-safe position by briefly interrupting the air supply.	Put the control valve out of operation (see the 'Decommissioning' section). Identify the cause for the malfunction and rectify it (see the 'Troubleshooting' section).

## 9.2 Preparing the valve for service work

---



We recommend removing the valve from the pipeline before performing any service work (see the 'Removal' section).

---

1. Lay out the necessary material and tools to have them ready for the service work.
  2. Put the control valve out of operation. See the 'Decommissioning' section.
  3. Remove the actuator from the valve. See associated actuator documentation.
- 



To remove an actuator with fail-safe action FC (fail close) and/or with preloaded springs, a certain signal pressure must be applied to the actuator (see associated actuator documentation). Afterwards, the signal pressure must be removed, and the air supply disconnected again and locked.

---

## 9.3 Installing the valve after service work

1. Mount actuator. See associated actuator documentation.
2. Adjust signal bench range. See associated actuator documentation.
3. If the valve has been removed, re-install the valve into the pipeline. See the 'Installation' section.
4. Put the control valve back into operation (see the 'Start-up' section). Observe the requirements and conditions for start-up or putting the valve back into operation.

## 9.4 Service work

- Before performing any service work, preparations must be made to the control valve (see section 9.2).
- After all service work is completed, check the control valve before putting it back into operation. See 'Testing the installed valve' in the 'Installation' section.
- For service work, see the associated maintenance instructions for the valve. Contact SAMSON VETEC After-sales Service: [sales-vetec-de@samsongroup.com](mailto:sales-vetec-de@samsongroup.com).

### 9.4.1 Retightening/adjusting the stuffing box packing

**i Note**

The stuffing box cannot be tightened with tightening torques due to the elasticity and compressibility of the packing rings/cords.

#### Stuffing box types for valve Types 82.7, 72.3, 72.4, 73.3, 73.7

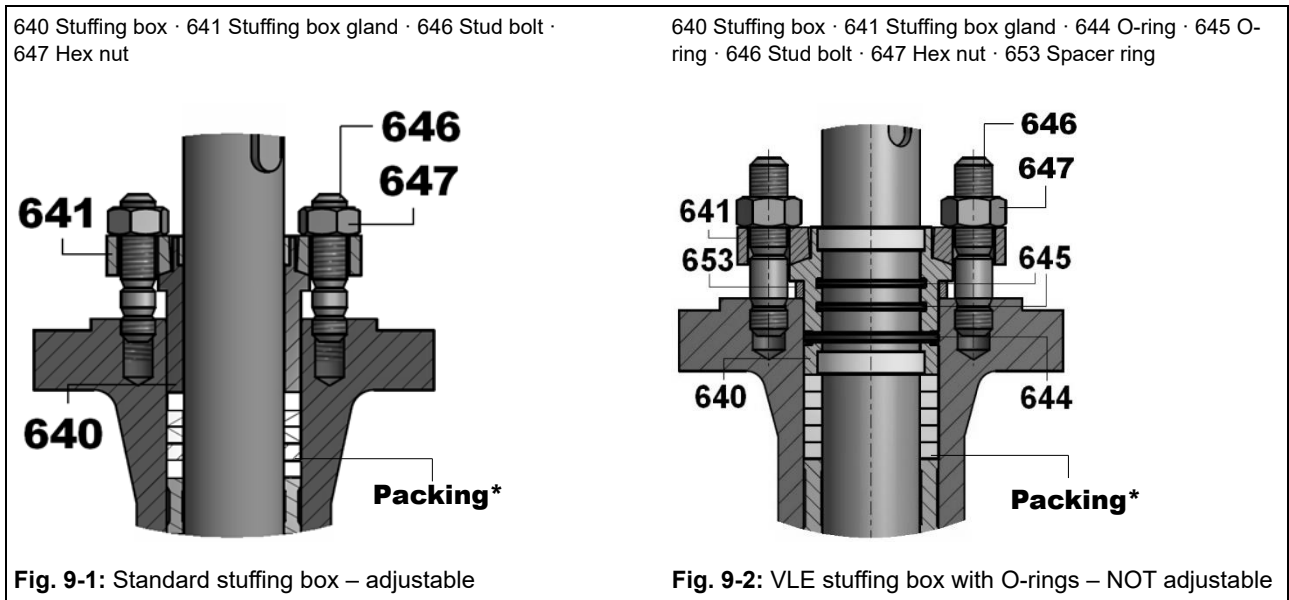

#### Stuffing box types for valve Types 82.7-02, 72.3-02, 72.4-02

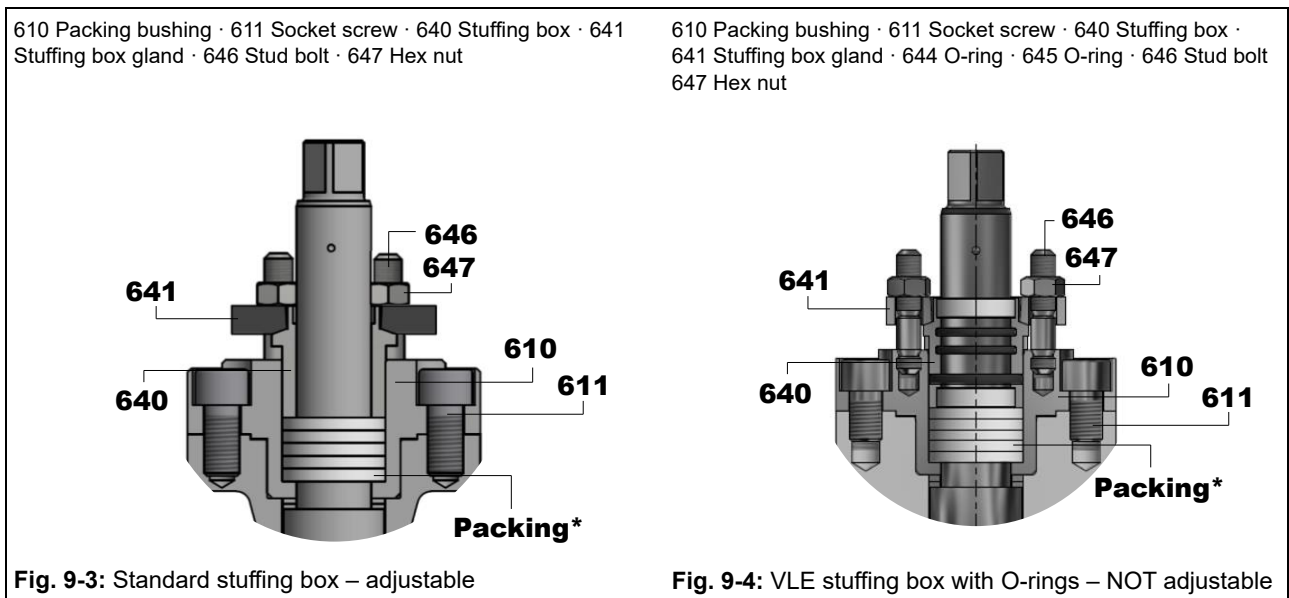

\* Packing: depending on the application, different packing rings/cords can be used.

**! NOTICE**

**Malfunction of the valve due to increased friction as a result of the stuffing box being tightened too far!**

Tightening the stuffing box too far can lead to increased friction in packing area and impair the shaft movement.

➔ Make sure that the shaft can still move smoothly after the stuffing box has been tightened.

---

Adjustable stuffing boxes can be tightened in the event of a leak.

To retighten/adjust the stuffing box packing, perform the following steps:

1. Tighten the stuffing box nuts (647) evenly (crosswise) and gradually in a clockwise direction until the stuffing box packing seals.
2. Open and close the valve several times.
3. Check the valve for leakage to the atmosphere.
4. Repeat steps 1 and 2 until the stuffing box packing completely seals.

➔ If the adjustable stuffing box packing does not seal properly, it must be replaced. Contact our after-sales service. After the tightness and function of the control valve have been checked for faultlessness, put the valve back into operation. See chapter 6 "Commissioning (start-up)" and chapter 7 "Operation".

## 9.5 Ordering spare parts and operating supplies

Contact SAMSON VETEC After-sales Service for information on spare parts and special tools: sales-vetec-de@samsongroup.com

### Spare parts

See spare parts lists.

### Lubricant

Use only suitable lubricants.

### Tools

Use only suitable tools.

## 10 Decommissioning

The work described in this section is only to be performed by personnel appropriately qualified to carry out such tasks.

---

### DANGER

#### **Risk of bursting due to incorrect opening of pressurized equipment or components.**

Valves and pipelines are pressure equipment that may burst when handled incorrectly. Flying projectile fragments or the release of process medium under pressure can cause serious injury or even death.

Before working on the control valve:

- Depressurize all plant sections affected and the valve (including the actuator). Release any stored energy.
  - Drain the process medium from all the plant sections concerned as well as the valve.
- 

### WARNING

#### **Risk of burn injuries due to hot or cold components and pipeline.**

Valve components and the pipeline may become very hot or cold. Risk of burn injuries.

- Allow components and pipelines to cool down or warm up to the ambient temperature.
  - Wear protective clothing and safety gloves.
- 

### WARNING

#### **Risk of personal injury due to pressurized components and process medium being discharged.**

- Do not loosen external pressurised parts (e.g. test connection, shaft blow-out protection screw (101) for valve types 72 and 73) while the valve is pressurised. See Fig. 7-1, 7-2.
- 

### WARNING

#### **Risk of hearing loss or deafness due to loud noise.**

Noise emission (e.g. cavitation or flashing) may occur during operation caused by the process medium and the operating conditions. Additionally, a loud noise may briefly occur through the sudden venting of the pneumatic actuator or pneumatic valve accessories not fitted with noise-reducing fittings. Both can damage hearing.

- Wear hearing protection when working near the valve
-

**⚠ WARNING**

**Crush hazard arising from moving parts.**

The valve contains moving parts (actuator piston rod/lever and valve shaft), which can injure hands or fingers if inserted into the valve.

- Before working on the valve, disconnect and lock the pneumatic air supply as well as the control signal.
  - Do not impede the movement of the actuator piston rod/lever and valve shaft by clamping objects.
  - Before unblocking the actuator piston rod and valve shaft after they have become blocked (e.g., due to seizing up after remaining in the same position for a long time), release any stored energy in the actuator (e.g., spring compression). See associated actuator documentation.
- 

**⚠ WARNING**

**Risk of personal injury due to exhaust air being vented.**

While the valve is operating, air is vented from the actuator, for example, during closed-loop operation or when the valve opens or closes.

- Wear eye protection when working in close proximity to the control valve.
- 

**⚠ WARNING**

**Risk of personal injury due to residual process medium in the valve.**

While working on the valve, residual medium can flow out of the valve and, depending on its properties, cause personal injury, e.g. (chemical) burns

- Wear protective clothing, safety gloves, respiratory protection and eye protection.
- 

To decommission the control valve for service work or to remove it from the pipeline, proceed as follows:

1. Close the shut-off valves upstream and downstream of the control valve to stop the process medium from flowing through the valve.
2. Completely drain the pipelines and valve.
3. Disconnect and lock the pneumatic air supply to depressurize the actuator.
4. Release any stored energy.
5. If necessary, allow the pipeline and valve components to cool down or warm up to the ambient temperature.

## 11 Removal

The work described in this section is only to be performed by personnel appropriately qualified to carry out such tasks.

---

### **WARNING**

#### **Risk of burn injuries due to hot or cold components and pipeline.**

Valve components and the pipeline may become very hot or cold. Risk of burn injuries.

- Allow components and pipelines to cool down or warm up to the ambient temperature.
- Wear protective clothing and safety gloves.

---

### **WARNING**

#### **Crush hazard arising from moving parts.**

The valve contains moving parts (actuator piston rod/lever and valve shaft), which can injure hands or fingers if inserted into the valve.

- Do not insert hands or finger into the bracket while the air supply is connected to the actuator.
- Before working on the valve, disconnect and lock the pneumatic air supply as well as the control signal.
- Do not impede the movement of the actuator piston rod/lever and valve shaft by clamping objects.
- Before unblocking the actuator piston rod and valve shaft after they have become blocked (e.g., due to seizing up after remaining in the same position for a long time), release any stored energy in the actuator (e.g., spring compression). See associated actuator documentation.

---

### **WARNING**

#### **Risk of personal injury due to residual process medium in the valve.**

While working on the valve, residual medium can flow out of the valve and, depending on its properties, cause personal injury, e.g. (chemical) burns

- Wear protective clothing, safety gloves, respiratory protection and eye protection.

---

### **WARNING**

#### **Risk of personal injury due to preloaded springs.**

Actuators with preloaded springs are under tension.

- Before starting any work on the actuator, relieve the compression from the preloaded springs (see associated actuator documentation).

## *Removal*

Before removing the valve, make sure the following conditions are met:

- The control valve is put out of operation (see the 'Decommissioning' section).

### **11.1 Removing the valve from the pipeline**

1. Support the valve to hold it in place when separated from the pipeline. See the 'Shipment and on-site transport' section.
2. Unbolt the flanges at the valve inlet and outlet.
3. Remove the valve from the pipeline. See the 'Shipment and on-site transport' section.

### **11.2 Removing the actuator from the valve**

See associated actuator documentation.

## 12 Repairs

If the valve does not function properly according to how it was originally sized or does not function at all, it is defective and must be repaired or exchanged.

---

### NOTICE

**Risk of valve damage due to incorrect service or repair work.**

→ Contact SAMSON VETEC After-sales Service for maintenance and repair work.

---

### 12.1 Returning devices to SAMSON VETEC

Defective devices can be returned to SAMSON VETEC for repair.

Proceed as follows to return devices:

1. Send an e-mail: [sales-vetec-de@samsongroup.com](mailto:sales-vetec-de@samsongroup.com) to register the return shipment including the following information:
  - Valve type
  - Serial number
  - Original order number
  - Completed Declaration on Contamination (Safety data sheet), which can be downloaded from our website at [vetec.samsongroup.com](http://vetec.samsongroup.com) > Service & Support > After-sales Service > Returning-goods.
2. Attach the Declaration on Decontamination (Safety data sheet) to the outside of your shipment so that the documents are clearly visible.
3. Send the shipment to the address given.

## **13 Disposal**

- ➔ Observe local, national and international refuse regulations.
- ➔ Do not dispose of components, lubricants and hazardous substances together with your household waste.

## 14 After-sales service

Contact our after-sales service for support concerning service or repair work or when malfunctions or defects arise.

### E-mail address

You can reach our after-sales service at : [sales-vetec-de@samsongroup.com](mailto:sales-vetec-de@samsongroup.com).

### Address of SAMSON VETEC

VETEC Ventiltechnik GmbH  
Siemensstrasse 12 · 67346 Speyer  
Phone: +49 6232 6412-0 · Fax: +49 6232 42479  
E-mail: sales-vetec-de@samsongroup.com · Internet: www.vetec.de

### Addresses of SAMSON AG & subsidiaries

The addresses of SAMSON AG, its subsidiaries, representatives and service facilities worldwide can be found on our website ([www.samsongroup.com](http://www.samsongroup.com)) or in all SAMSON product catalogues.

### Required specifications

Please submit the following details:

- Order number and position number in the order
- Type, model number, valve size and valve version
- Pressure and temperature of the process medium
- Flow rate in m<sup>3</sup>/h
- Direction of flow
- Bench range of the actuator
- Is a strainer (noise reduction) installed?
- Installation drawing



**VETEC Ventiltechnik GmbH**

Siemensstrasse 12 · 67346 Speyer · Germany  
Phone: +49 6232 6412-0 · Fax: +49 6232 42479  
E-mail: [sales-vetec-de@samsongroup.com](mailto:sales-vetec-de@samsongroup.com)  
Internet: [vetec.samsongroup.com](http://vetec.samsongroup.com)