



Rotary Plug Valve Series 82 · Type 82.7-02 (Design Generation 02)

Application

Control valve for process engineering and industrial applications.



	DIN	ANSI	
Valve size	DN 25 to 350	NPS 1 to 14	
Pressure rating	PN 10, 16, 25, 40	Class 150, 300	
Permissible temperature range	-196 to +500 °C	-321... +932 °F	Different designs

Features

Rotary plug valve operated with:

- pneumatic piston actuator Type AT / BR31a → control valve Type 82.7-02/AT and 82.7-02/BR31a (see fig. 1)
- pneumatic rolling diaphragm actuator Type R → control valve Type 82.7-02/R (Fig. 2)
- pneumatic diaphragm actuator Type MZ → control valve Type 82.7-02/MZ (from DN 100) (see fig. 3)
- pneumatic diaphragm actuator Type MD → control valve Type 82.7-02/MD (from DN 100) (see fig. 4)

The rotary plug valve can also be configured with an electric or hydraulic actuator.

The control valves, designed according to the modular assembly principle, can be equipped with various accessories: positioner, limit switches, solenoid valves, and other accessories acc. to VDI/VDE 3845-1 (EN 15714-3), resp. VDI/VDE 3847-2 for actuator Type AT.

Body material

- Cast steel
- Cast stainless steel
- Forged steel or forged stainless steel
- Special materials (Superduplex, Monel®, Hastelloy®, Titan etc.)

Valve seat

- Metal seal
- Soft seal
- Various seat factors (Standard: F1; F0,6; F0,4; F0,25)

Standard versions

- For temperatures from -40 to +350 °C

Configuration samples: rotary plug valves with pneumatic rotary actuators

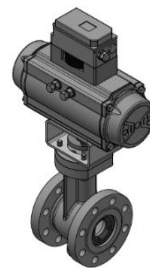

Fig. 1: Type 82.7-02/AT (BR31a)

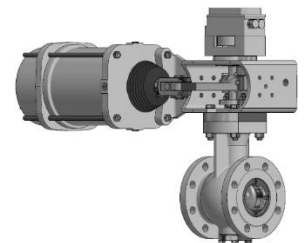

Fig. 2: Type 82.7-02/R



Fig. 3: Type 82.7-02/MZ



Fig. 4: Type 82.7-02/MD

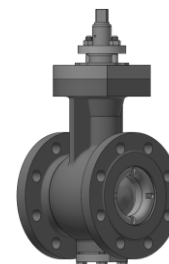

Fig. 5: Valve Type 82.7-02 · Standard version

Further versions

- SAMSON VETEC low emission packing (VLE) optionally certified according to DIN EN ISO 15848-1*/TA Luft 2021* (see fig. 17).
- Components for noise and cavitation reduction ► TY005.036
- **Bearing seals** (see fig. 18 and 19)

* Pressure rating and temperature class on request.

- **Insulating section IT1**** - High and low temperature extension: -40 to -100 °C und 350 to 500 °C (see fig. 6)
- **Insulating section IT2**** - Temperature extension for cryogenic media: -100 to -196 °C (see fig. 7).
- **Double stuffing box DSB** - with or without test connection (see fig. 8)
- **Heating jacket HZM** from DN 150 (see fig. 9)
- Valve made of forged material with **protective sleeve** of hardened metal, tungsten carbide or ceramic (see fig. 10)
- **Flushing connections** for the plug, trunnion bearing, retainer ring and shaft (see fig. 11)

**The design may vary depending on the sealing elements installed (e.g., packing, O-rings) and operating parameters. The specified temperature values are only to be understood as guide values. The design of the valve is checked in each individual case.

Flange

Flange version acc. to DIN EN1092-1: Standard B1/B2 and optionally with groove (D), male face/female (F). Other versions on request.

Principle of operation

The offset between the plug face and shaft centre and the offset between the shaft centre and valve centreline give the rotary plug valve its double eccentric (double offset) design (see fig.12/13). When opening and closing the valve, this double eccentric design allows the plug to lift smoothly off the seat without any friction, eliminating any breakaway torque. This smooth opening also allows for stable control, even at small opening angles.

Fail-safe action

With single-acting rotary actuators, the control valve has two different fail-safe positions which become effective when the pressure on the diaphragm or the piston is relieved or when the power supply fails:

- **FO** = spring opens (fail-open): the valve is open by the spring force of the actuator upon failure of power supply.
- **FC** = spring closes (fail-close): the valve is closed by the spring force of the actuator upon failure of power supply.

Flow Direction

The valve can be used in both flow directions, depending on the medium, operating conditions and flow requirements:

- **FTC** = Flow-to-close
- **FTO** = Flow-to-open

Installation:

An arrow on the valve will indicate the direction of flow the valve has been configured for.

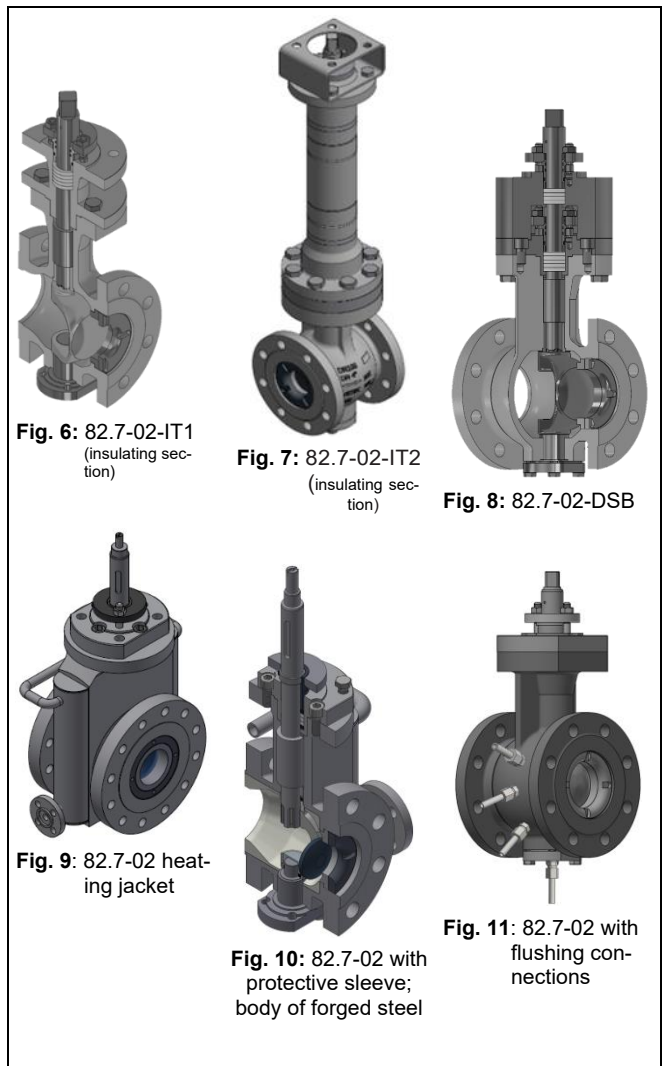

Type 82.7 closes counterclockwise and has an opening angle of 75°.

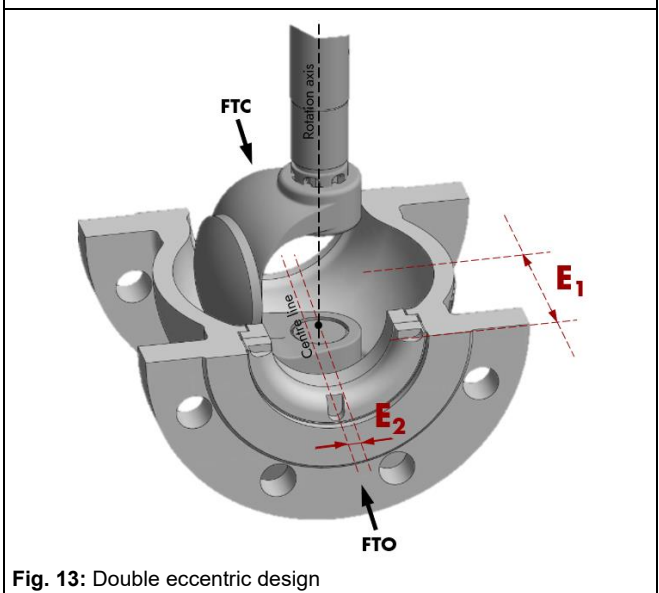
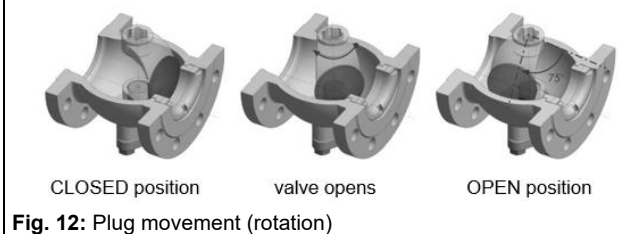
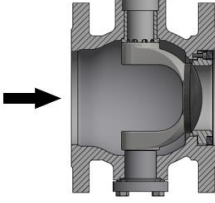
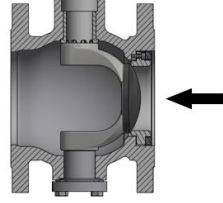

Table 1: Technical Data

Design parameters		DIN	ANSI
Valve size		DN 25, 40, 50, 80, 100, 150, 200, 250, 300, 350	NPS 1, 1½, 2, 3, 4, 6, 8, 10, 12, 14
Pressure rating		PN 10 · 16 · 25 · 40	Class 150, 300
Max. operating pressure		40 bar(g)	50 bar(g)
Max. perm. differential pressure		see data sheet ►TY005.069	
Face-to-face dimensions		EN 558, series 36, 15	
Connection	Flange	DIN EN 1092-1	ASME B16.5
Seat-plug seal		metal sealing or soft sealing	
Standard seat factors		F1 (100%) · F0,6 (60%) · F0,4 (40%) · F0,25 (25%)	
Characteristic		natural · equal percentage · linear · ON/OFF	
Rangeability		up to 200:1	
Opening angle		75°	
Plug movement (direction of rotation)		closing counterclockwise	
Flow direction		 Flow to close (FTC)	 Flow to open (FTO)
Temperature range ¹⁾			
Body	Without insulating section	-40 to +350 °C	-40... +662 °F
	With insulating section IT1 (short)	-100 to -40 °C and 350 to 500 °C	-148... -40 and 662... 932 °F
	With insulating section IT2 (long)	-196 to -100 °C	-321... -148 °F
Leakage-Klasse acc. to DIN EN 60534-4			
Seat	Metal seal	IV	
	Soft seal	VI	
Actuator type		Pneumatic, electric or hydraulic rotary actuators and manual override	
Conformity		CE TSG EAC	

¹⁾ The design may vary depending on the sealing elements installed (e.g., packing, O-rings) and operating parameters. The specified temperature values are only to be understood as guide values. The design of the valve is checked in each individual case.

Table 2.1: Standard materials DIN

Item	Part	Material / max. permissible temperature in °C			Assembly drawing Type 82.7-02
100	Body	Cast steel 1.0619 -10...+400 °C		Cast stainless steel 1.4408 -196...+500 °C	
200	Plug	R30006 (Stellite® 6) -10...+400 °C		1.4408 (stellite/ hardened) -196...+500 °C	
300	Shaft	1.4542 (17-4PH®) -29...+315 °C	1.4404 -196...+400°C	1.4980 -196...+500 °C	
400	Trunnion bearing	1.4404 (stellite/ hardened)		1.4408 (stellite/ hardened)	
500	Seat ring	1.4404 (stellite/ hardened)		1.4408 (stellite/ hardened)	
501	Seat holder	1.4404		1.4408	
610	Packing bushing	1.4404			
620/ 621	Packing (*)	PTFE/Graphite -29...+280 °C		Graphite -196...+500 °C	
-/-	Gasket	VA/Graphite			
644/ 645	O-ring	FPM 80			

(*) Depending on the application, different packaging ring materials and packaging ring combinations can be used. The number of packaging rings (5) remains constant.
Other materials available on request.

Table 2.1: Standard materials ANSI

Item	Part	Material / max. permissible temperature in °F			Assembly drawing Type 82.7-02
100	Body	Cast steel A216 WCC 14... 752 °F		Cast stainless steel A351 CF8M -321... +932 °F	
200	Plug	R30006 (Stellite® 6) 14...752 °F		A351 CF8M (stellite/ hardened) -321...+932 °F	
300	Shaft	1.4542 (17-4PH®) -20...+599 °F	1.4404 -321...+752°F	1.4980 -321...+932 °F	
400	Trunnion bearing	316 L (stellite/ hardened)		A351 CF8M (stellite/ hardened)	
500	Seat ring	316 L (stellite/ hardened)		A351 CF8M (stellite/ hardened)	
501	Seat holder	316 L		A351 CF8M	
610	Packing bushing	316 L			
620/ 621	Packing (*)	PTFE/Graphite -20...+536 °F		Graphite -321...+932 °F	
-/-	Gasket	VA/Graphite			
644/ 645	O-ring	FPM 80			

(*) Depending on the application, different packaging ring materials and packaging ring combinations can be used. The number of packaging rings (5) remains constant.
Other materials available on request.

- Design change (extended design)

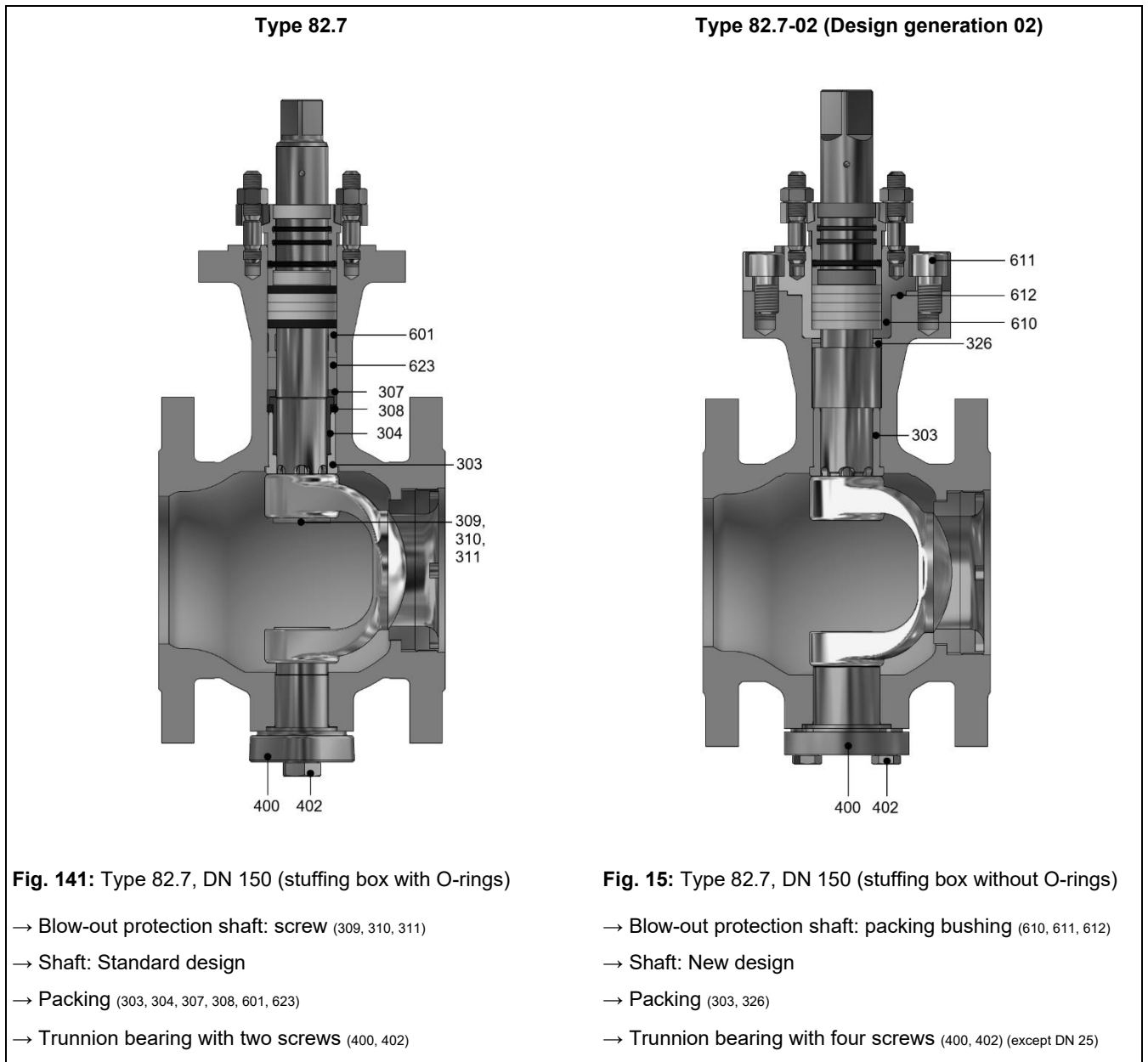

- Designs versions

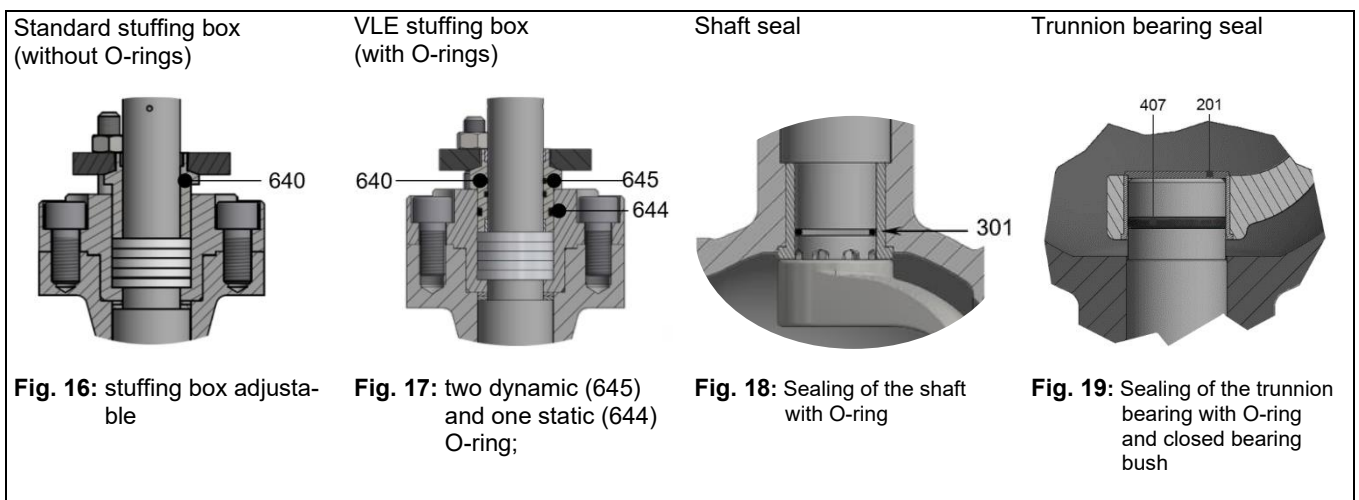

- **Flow Characteristics • Kvs/Cv-Coefficient**

The natural (inherent) design characteristic (fig. 20) of the rotary plug valve can be modified to achieve a linear or equal percentage (logarithmic) characteristic (fig. 21) using a positioner.

The flow coefficient (Kvs/Cv) depends on the opening angle of the valve.

→ Kvs/Cv coefficients according to overview ► TY005.085

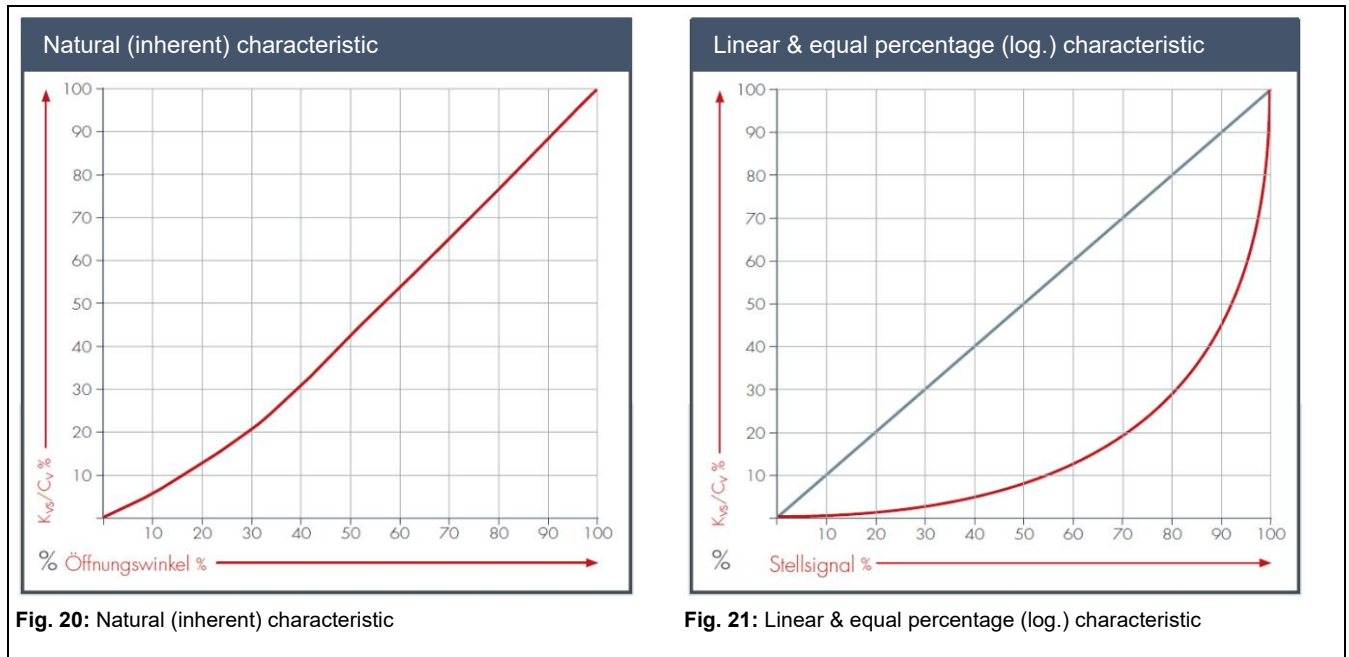

• **Valve-actuator combinations**

Table 3: Control valve Type 82.7/AT (SC/SO/DL) (see fig.1)

Actuator size		60	100	150	220	300	450	600	900	1200	2000	3000	4000	5000	10000
Flange connection		F07	F07	F7/F10	F7/F10	F7/F10	F10/F12	F10/F12	F14	F14	F16	F16	F16	F16/F25	F16/F25/F30
Valve		Valve - actuator combinations ⁽¹⁾													
DN	FC ⁽²⁾														
25	F10	✓	✓	—	—	—	—	—	—	—	—	—	—	—	—
40	F12	—	✓	✓	✓	—	—	—	—	—	—	—	—	—	—
50	F12	—	✓	✓	✓	✓	—	—	—	—	—	—	—	—	—
80	F12	—	—	✓	✓	✓	✓	✓	—	—	—	—	—	—	—
100	F14	—	—	—	✓	✓	✓	✓	✓	✓	—	—	—	—	—
150	F16	—	—	—	—	—	✓	✓	✓	✓	✓	✓	—	—	—
200	F16	—	—	—	—	—	✓	✓	✓	✓	✓	✓	✓	—	—
250	F16	—	—	—	—	—	—	—	✓	✓	✓	✓	✓	✓	✓
300	F16	—	—	—	—	—	—	—	—	✓	✓	✓	✓	✓	✓
350	F25	—	—	—	—	—	—	—	—	—	✓	✓	✓	✓	✓

Table 4: Control valve Type 82.7-02/R (see fig.2)

Actuator size		R110	R110v	R150	R150v	R200	R200v	R250	R250v	R250vv
Spring range in bar(g)		0,4-1,2	1,16-2,76	0,4-1,2	0,92-2,76	0,4-1,2	1,25-2,65	0,4-1,2	1,3-2,4	1,7-3,3
Valve		Valve - actuator combinations ⁽¹⁾								
DN	FC ⁽²⁾									
25	F10	✓	✓	—	—	—	—	—	—	—
40	F12	✓	✓	✓	—	—	—	—	—	—
50	F12	✓	✓	✓	✓	—	—	—	—	—
80	F12	—	✓	✓	✓	✓	✓	✓	—	—
100	F14	—	✓	✓	✓	✓	✓	✓	—	—
150	F16	—	—	—	✓	✓	✓	✓	✓	✓
200	F16	—	—	—	✓	✓	✓	✓	✓	✓
250	F16	—	—	—	—	✓	✓	✓	✓	✓
300	F16	—	—	—	—	✓	✓	✓	✓	✓
350	F25	—	—	—	—	—	✓	✓	✓	✓

Table 5: Control valve Type 82.7-02/MZ (see fig.4)

Actuator size		MZ450	MZ450v	MZ700	MZ700v
Spring range in bar(g)		0,45-1,30	0,88-2,10	0,40-1,28	0,69-2,05
Valve		Valve - actuator combinations ⁽¹⁾			
DN	FC ⁽²⁾				
25	F10	—	—	—	—
40	F12	—	—	—	—
50	F12	—	—	—	—
80	F12	—	—	—	—
100	F14	—	—	—	—
150	F16	✓	✓	✓	—
200	F16	✓	✓	✓	✓
250	F16	✓	✓	✓	✓
300	F16	✓	✓	✓	✓
350	F25	✓	✓	✓	✓

⁽¹⁾ Combination depending on differential pressure, fail-safe position (FC/FO), flow direction (FTC/FTO); see ► Data sheet TY005.069 differential pressure table

⁽²⁾ FC = valve flange connection to actuator

Table 6: Control valve Type **82.7-02/MD** (see fig.3)

Actuator size		MD450				MD 700					
Spring range in bar(g)		0,65-1,1	1,15-2,01	1,56-2,72	1,71-3,13	0,7-1,3	1,51-2,8	1,74-3,1	2,1-3,75	2,51-4,07	2,88-4,66
Valve		Valve - actuator combinations ⁽¹⁾									
DN	FC ⁽²⁾										
25	F10	—	—	—	—	—	—	—	—	—	—
40	F12	—	—	—	—	—	—	—	—	—	—
50	F12	—	—	—	—	—	—	—	—	—	—
80	F12	—	—	—	—	—	—	—	—	—	—
100	F14	—	—	—	—	—	—	—	—	—	—
150	F16	✓	✓	✓	✓	—	—	—	—	—	—
200	F16	✓	✓	✓	✓	✓	—	—	—	—	—
250	F16	✓	✓	✓	✓	✓	✓	✓	✓	✓	—
300	F16	✓	✓	✓	✓	✓	✓	✓	✓	✓	—
350	F25	✓	✓	✓	✓	✓	✓	✓	✓	✓	✓

⁽¹⁾Combination depending on differential pressure, fail-safe position (FC/FO), flow direction (FTC/FTO); see ► Data sheet TY005.069 differential pressure table

⁽²⁾FC = valve flange connection to actuator

- **Installation positions of the control valve and assembly position of the actuator**

HINWEIS

Risk of malfunction or damage to the control valve due to incorrect installation in the pipeline!

- ➔ Install the control valve in the pipeline so that the condensate can drain off.
- ➔ The plug must not swing downwards, as it can jam due to deposits of the medium.
- ➔ Observe the permissible installation position of the accessories (e.g. supply pressure regulator). See associated mounting and operating instructions.
- ➔ Actuators type MN must only be installed, transported, lifted or stored in a vertical position (with the piston rod vertical to the pipe).

- For the correct sizing of the actuator, the mounting position differing from the standard has to be specified when ordering the control valve.
- **Mounting Type A** is selected as the **standard** mounting position for **AT** and **R actuators** if no other specifications are provided.
- **Mounting Type B** is selected as the **standard** mounting position for **M actuators** if no other specifications are provided.

For the permissible **installation positions** of the **rotary plug valves** with **actuators Type AT, R and M** in the pipeline and **assembly positions** of the **actuators** on the valves, see ► data sheet **TY005.071**.

• **Mounting dimensions for standard versions**

Table 8: Face-to-face dimensions according to DIN EN 558

Valve size	DN	25	40	50	80	100	150	200	250	300	350
	NPS	1	1½	2	3	4	6	8	10	12	14
Pressure rating	PN	10, 16, 25, 40									
	Class	150, 300									
Face-to-face dim. in mm		102	114	124	165	194	229	243	297	338	550
Face-to-face dim. in inch		4.00	4.48	4.88	6.49	7.63	9.00	9.56	11.69	13.30	21.65
Series		36	36	36	36	36	36	36	36	36	15

Table 9: Control Valve Type 82.7-02/AT · Assembly position A/C · FO/FC (fail-open / fail-close)

Valve size	DN	25	40	50	80	100	150	200	250	300	350
Actuator (combination example)		60	100	100	150	300	450	600	900	1200	2000
Dimension	Pressure rating	Dimensions in mm									
A	PN 10, 16, 25, 40	102	114	124	165	194	229	243	297	338	550
B		51	57	62	82,5	97	119,5	131,5	163,5	184	275
C		271	292,5	302,5	367	401	506	530	583,5	628	778
E		73	76	86	114	129	155	175	222,5	243	303,1
K		102	121	121	130	167	198	212	237	264	302,5
L		55	68	69	81	99	114	120	138	156	140
M		53	52	51	55	67	74	79	85	96	131
N		102	121	121	130	167	198	212	237	264	302,5
R		336	343	343	349	364	374	383	425	438	441,5

A minimum of 200 mm of space around the actuator must be planned for the piping of the accessories.

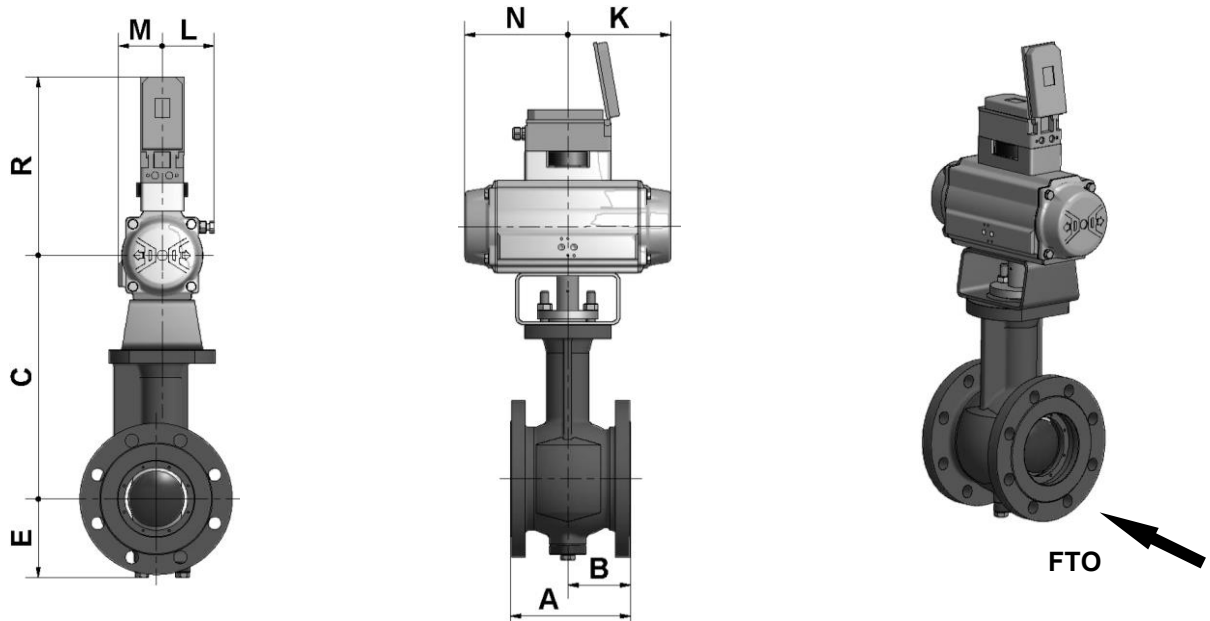

Fig. 22: Dimensions - Control valve Type 82.7-02/AT · Assembly position A/C · FO/FC

Information may differ slightly. The images shown are for illustration purposes only. The actual product may vary.

Table 10: Control Valve Type **82.7-02/R** · Assembly position **A** · **FC** (fail-close)

Valve size	DN	25	40	50	80	100	150	200	250	300	350
Actuator (combination example)		R110v	R150	R150v	R200	R200v	R250	R250v	R250vv	R250vv	
Dimension	Pressure rating	Dimensions in mm									
A	PN 10, 16, 25, 40	102	114	124	165	194	229	243	297	338	550
B		51	57	62	82,5	97	119,5	131,5	163,5	184	275
C		199	213,5	237,5	296	316	426	444	485,5	507	617,2
E		73	76	86	114	129	155	175	222,5	243	303,1
K		502	502	616	616	682	687	738	822	822	822
L		86	86	120	120	127	127	127	127	127	127
M		89	89	100	100	124	129	130	130	130	130
N		154	154	196	196	252	252	340	340	340	340
R		359	359	373	373	374	392	392	392	392	392

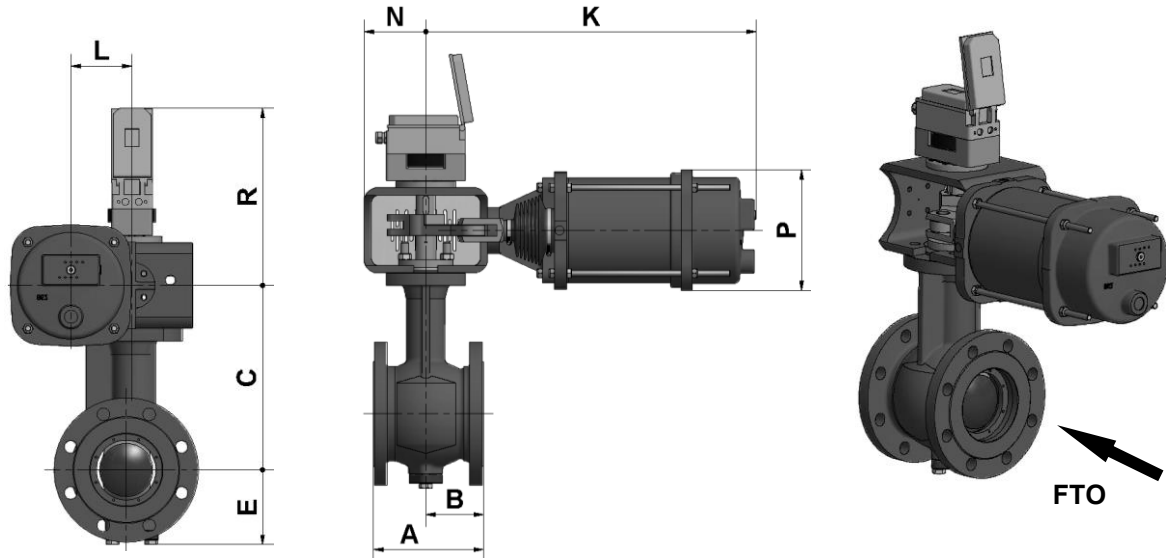

Fig. 23: Dimensions - Control valve Type **82.7-02/R** · Assembly position **A** · **FC** (fail close)

Information may differ slightly. The images shown are for illustration purposes only. The actual product may vary.

Table 11: Control Valve Type **82.7-02/MZ** · Assembly position **B** · **FC** (fail-close)

Valve size	DN	25	40	50	80	100	150	200	250	300	350
Actuator (combination example)						MZ450	MZ450	MZ450v	MZ700	MZ700v	MZ700v
Dimension	Pressure rating	Dimensions in mm									
A	PN 10, 16, 25, 40					194	229	243	297	338	550
B						97	119,5	131,5	163,5	184	275
C						384	479	484	571,5	593	706
E						129	155	175	222,5	243	303
K						1310	1312	1314	1456	1456	1456
L						65	65	65	85	85	85
N						140	138	136	139	139	237
P						557	557	557	756	756	756
R						454	454	454	479	479	479

Table 12: Control Valve Type **82.7-02/MD** · Assembly position **B** · **FC** (fail-close)

Valve size	DN	25	40	50	80	100	150	200	250	300	350
Actuator (combination example)							MD450	MD450	MD700	MD700	MD700
Dimension	Pressure rating	Dimensions in mm									
A	PN 10, 16, 25, 40						229	243	297	338	550
B							119,5	131,5	163,5	184	275
C							481	496	571,5	593	706,2
E							155	175	222,5	243	303,1
K							1120	1122	1557	1557	1557
L							65	65	85	85	85
N							167	165	221	221	221
P							557	557	756	756	756
R							454	454	488	488	488

When piping the accessories, a minimum clearance of 200 mm around the actuator must be planned.

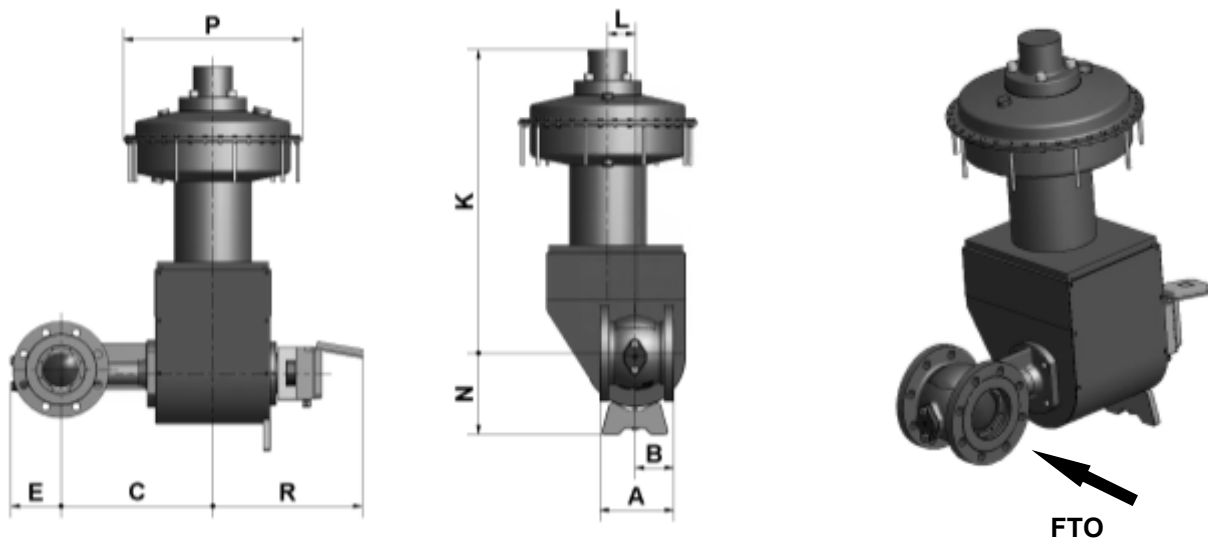

Fig. 24: Dimensions - Control valve Type 82.7-02 with MZ and MD · Assembly position B · FC (fail close)

Information may differ slightly. The images shown are for illustration purposes only. The actual product may vary.

• **Weights for standard versions (*)**

Table 13: Control Valve Type 82.7-02/AT

Actuator size	60	100	150	220	300	450	600	900	1200	2000	3000	4000	5000	10000	
Actuator + bracket in kg	6	7	9	16	19	24	30	42	55	75	112	150	180	238	
DN	Valve w. in kg	Weight control valve (without accessories) in kg													
25	7,5	13,5	14,5	—	—	—	—	—	—	—	—	—	—	—	
40	12,5	—	19,5	21,5	28,5	—	—	—	—	—	—	—	—	—	
50	15,5	—	22,5	24,5	31,5	34,5	—	—	—	—	—	—	—	—	
80	27	—	—	36	43	46	51	57	—	—	—	—	—	—	
100	43	—	—	—	59	62	67	73	85	98	—	—	—	—	
150	73	—	—	—	—	—	97	103	115	128	148	185	—	—	
200	97	—	—	—	—	—	—	127	139	152	173	209	247	—	
250	154	—	—	—	—	—	—	—	196	209	229	266	304	334	
300	169	—	—	—	—	—	—	—	—	224	244	281	319	349	
350	435	—	—	—	—	—	—	—	—	490	510	547	585	615	

Table 14: Control Valve Type 82.7-02/R

Actuator size	R110	R110v	R150	R150v	R200	R200v	R250	R250v	R250vv	
Actuator + bracket in kg	17,5	18	29	30	52	54	79	82	93	
DN	Valve w. in kg	Weight control valve (without accessories) in kg								
25	7,5	25	25,5	—	—	—	—	—	—	
40	12,5	30	30,5	41,5	—	—	—	—	—	
50	15,5	33	33,5	44,5	45,5	—	—	—	—	
80	27	—	45	56	57	79	81	106	—	
100	43	—	61	72	73	95	97	122	—	
150	73	—	—	—	103	125	127	152	155	
200	97	—	—	—	127	149	151	176	179	
250	154	—	—	—	—	206	208	233	236	
300	169	—	—	—	—	221	223	248	251	
350	435	—	—	—	—	487	489	514	517	

Table 15: Control Valve Type 82.7-02/MD

Actuator size	MD450					MD700					
Spring range in bar(g)	0.65-1.1	1.15-2.01	1.56-2.72	1.71-3.13	0.7-1.3	1.51-2.8	1.74-3.1	2.1-3.75	2.51-4.07	2.88-4.66	
Actuator + bracket in kg	350	355	360	370	645	655	670	680	690	700	
DN	Valve w. in kg	Weight control valve (without accessories) in kg									
25	7,5	—	—	—	—	—	—	—	—	—	
40	12,5	—	—	—	—	—	—	—	—	—	
50	15,5	—	—	—	—	—	—	—	—	—	
80	27	—	—	—	—	—	—	—	—	—	
100	43	—	—	—	—	—	—	—	—	—	
150	73	423	428	433	443	—	—	—	—	—	
200	97	447	452	457	467	742	—	—	—	—	
250	154	504	509	514	524	799	809	824	834	844	
300	169	519	524	529	539	814	824	839	849	859	
350	435	785	790	795	805	1080	1090	1105	1115	1125	

Table 16: Control Valve Type 82.7-02/MZ

Actuator size	MZ450	MZ450v	MZ700	MZ700v
Spring range in bar(g)	0.45-1.30	0.88-2.10	0.40-1.28	0.69-2.05
Actuator + bracket in kg	165	170	510	520
DN	Valve w. in kg	Weight control valve (without accessories) in kg		
25	7,5	—	—	—
40	12,5	—	—	—
50	15,5	—	—	—
80	27	—	—	—
100	43	—	—	—
150	73	238	243	583
200	97	262	267	607
250	154	319	324	664
300	169	334	339	679
350	435	600	605	945

(*) Reference values; the weights may vary depending on the pressure rating, seat factor and material.

- **Ordering text**

Rotary plug valves	Type ...
Valve size	DN ...
Pressure rating	PN ...
Material	Acc. to table 2.1/2.2 or special materials
Type of end connection	Flange
Seat/plug seal	Metal sealing, soft sealing
Flow characteristic	Equal percentage or linear
Rotary actuator	Pneumatic, electric, hydraulic
Fail-safe position	Fail-close or fail-open
Process medium	Density and temperature
Max. flow rate	kg/h or m ³ /h
Operating pressure	p1 and p2 in bar (absolute pressure)
Accessories	Positioner/limit switch etc.
Others	Certificates, manufacturer's declaration etc.

Related documents

TY005.069	Max. permissible differential pressures Δp
TY005.085	Kvs / Cv coefficients
TY005.071	Mounting types of the actuators
TY005.xxx	Data sheet of the associated actuator