



1. Design and principle of operation

The **Type 2114/2418** Excess Pressure Valve consists of the **Type 2114** Control Valve and the **Type 2418** Opening Actuator.

The excess pressure valve is used to keep the upstream pressure constantly on the preset set point.
The valve opens when the upstream pressure increases.

The process medium flows through the valve between seat (2) and plug (3) in the direction indicated by the arrow.

The position of the valve plug determines the flow rate, and hence the pressure ratio at the valve. The upstream pressure is transmitted via the control line (19) to the operating diaphragm where it is converted into a positioning force. The positioning force is used to move the valve plug, depending on the force

of the adjustment springs (11). The load of the springs can be adjusted at the set point adjuster (13).

The control valves are equipped with a balancing bellows (5), the outside of which is subject to the upstream pressure and the inside to the downstream pressure. In this way, the forces occurring at the valve plug due to the upstream and downstream pressure can be balanced out.

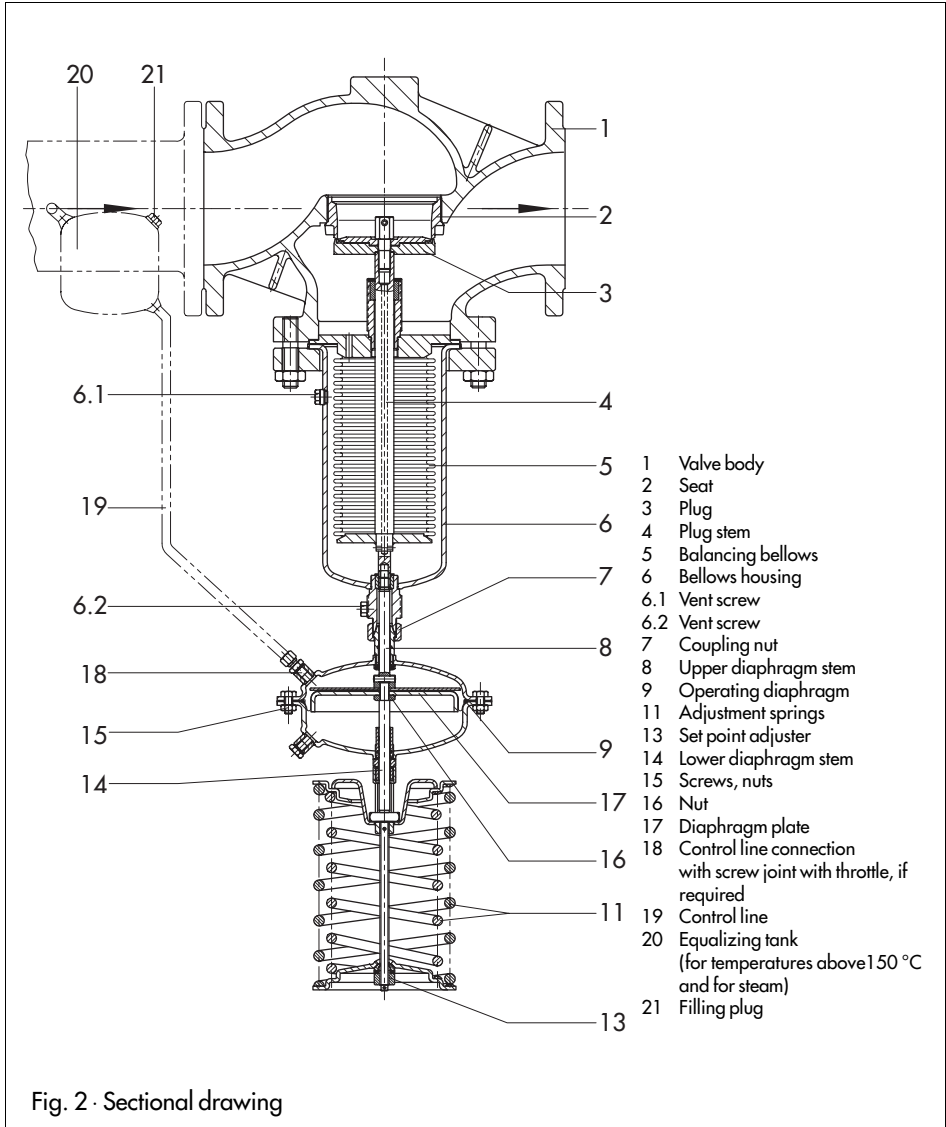

2. Installation

2.1 Assembly

The valve and actuator may be assembled either before or after the control valve has been installed in the pipeline.

DN 15 to 100

Screw the actuator to the bellows housing (6) of the valve using the coupling nut (7). Make sure the control line connection (18) is installed on the side of the valve where the upstream pressure line is located.

DN 125 to 250 – Attention!

The diaphragm stem and the plug stem must be screwed together!

When installing the control valve and actuator later, you are required to check if they fit:

The control valve must have a tapped hole at the end of the plug stem.

Valve versions designed for attachment of a thermostat (Type 4 Temperature Regulator) have a threaded nipple screwed in the end of the plug stem – this nipple must be removed!

The actuator must have a diaphragm stem with a threaded end! Versions without a threaded plug stem cannot be used.

Place the actuator on the valve bonnet and carefully screw in until it stops, now turn back by one turn at maximum.

Hold the actuator tight and fasten it to the bellows housing using the coupling nut (7).

Make sure the control line connection is in the proper position, pointing to the upstream pressure line.

2.2 Mounting position

The excess pressure valve is to be installed in horizontal pipelines, the actuator suspended in downward direction. The process medium must flow in the direction indicated by the arrow on the body.

When choosing the place of installation make sure the valve can still be easily accessed after the completion of the plant.

The valve must be installed free of stress. If needed, support the pipelines near the connecting flanges.

Do not mount any supports on the valve or on the actuator!

Flush the pipeline thoroughly prior to installing the valve, since sealing particles, globules and other impurities carried along by the process medium could impair the proper functioning and, especially the tight shut-off. A strainer (SAMSON Type 2) must be installed upstream of the excess pressure valve.

2.3 Strainer

The strainer is ideally installed upstream of the excess pressure valve and the pressure sensing point. The process medium must flow in the direction indicated by the arrow on the housing. The filter element is to be suspended downwards. Take care to leave enough space for disassembling the filter element.

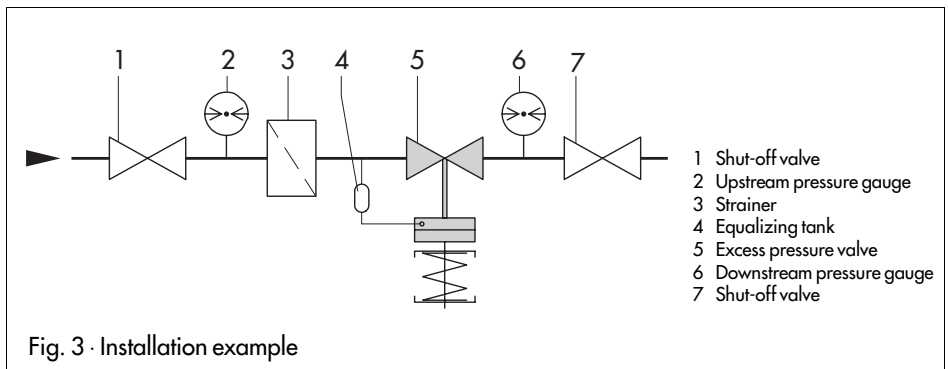

Fig. 3 · Installation example

2.4 Control line, equalizing tank and screw joint with throttle

The control line must be a 3/8" pipe which has to be provided by the customer. If it is to be made of copper, it is recommended to use a 12 x 1 mm pipe.

An equalizing tank is required when using liquids exceeding 150 °C or steam.

If the pressure exceeding valve tends to oscillate, ideally, a SAMSON screw joint with throttle should be installed in the control line connection (18).

The control line must be connected to the upstream pressure line, at least 1 m away from the valve inlet. It must be laterally welded into the center of the pipeline and installed with a steady upward slope of approx. 1 : 10 towards the equalizing tank. The mounting position of the equalizing tank is marked by an adhesive label and an arrow indicating the top of the tank. This mounting position must be strictly observed in order to ensure the reliable functioning of the excess pressure valve.

The pipeline coming from the sensing point is welded to the 3/8" pipe sleeve of the equalizing tank. The equalizing tank must always be located on the highest point of the pipeline, this means, the control line between the equalizing tank and the actuator must have a downward slope. Here, a 3/8" pipe with screw joint is to be provided.

2.5 Shut-off valves

Ideally, hand-operated shut-off valves should be installed upstream of the strainer and downstream of the excess pressure valve. This allows the plant to be shut down for cleaning and maintenance procedures and when the plant is not used for an extended period of time.

2.6 Pressure gauges

For monitoring the pressures prevailing throughout the plant, it is recommended to install pressure gauges upstream and downstream of the excess pressure valve.

3. Operation

3.1 Start-up

Controlling steam:

Screw out the filling plug (21) at the equalizing tank and fill it with water by means of a plastic funnel or a can until the water in the filling plug overflows.

Tightly screw in the filling plug. Now, the excess pressure valve is ready to be operated. Open the hand-operated shut-off valves very slowly in order to prevent water hammer.

Controlling liquids:

Put the excess pressure valve into operation by slowly opening the shut-off valves. For the 640 cm² actuator, loosen the vent screw to release the air. Then, fasten it again. At temperatures above 150 °C, the required equalizing tank must be filled up with the process medium prior to performing the steps mentioned above.

3.2 Adjusting the set point

The desired excess pressure (upstream pressure) is adjusted simply by turning the set point adjuster (6).

Turning clockwise increases the excess pressure, whereas turning anti-clockwise decreases it. The adjusted set point can be checked by reading the pressure gauge installed in the upstream pressure line.

Change of the set point range:

The set point range is determined by the size of the actuator and its adjustment springs. The set point range can only be changed if the whole actuator is replaced. We recommend to consult the manufacturer on this item.

3.3 Troubleshooting

If the excess pressure (pressure gauge in the upstream pressure line) differs considerably from the adjusted set point, first check the control line for blockages and the operating diaphragm for leaks.

If this problem is due to other causes such as a damaged seat and plug, you should contact the customer service or send the valve back to the manufacturer for repair.

If the operating diaphragm is damaged, proceed as described in Section 3.3.1.



When performing any assembly work, first depressurize the relevant part of the plant and drain it, if necessary. Then, remove the excess pressure valve from the pipeline.

3.3.1 Replacing the operating diaphragm

If just the operating diaphragm is defective, drain the relevant part of the plant. Then, screw off the control line and separate the actuator from the valve. The control valve need not be removed from the pipeline. When removing the actuator, the valve must be drained by loosening the coupling nut.

Loosen the screws (15) at the actuator and remove the lower diaphragm case together with the diaphragm stem (14) and the spring assembly.

Unscrew the nut (16), while holding against the lower diaphragm stem with an appropriate tool (for nominal sizes of DN 125 and larger, the upper diaphragm stem is secured through a pin which must be knocked out first).

Lift off the diaphragm plate (17) and pull out the diaphragm. Insert a new diaphragm.

To reassemble, proceed in the reverse order. Make sure the actuator cone seals the control valve properly.

To put back into operation, see section 3.1.

4. Dimensions in mm and weights

Nominal size	DN	15	20	25	32	40	50	65	80	100	125	150	200	250	
Length	L	130	150	160	180	200	230	290	310	350	400	480	600	730	
Height	H1	225			275			380		410	460	590	600	600	
	H2	55			72			100		120	145	175	215	230	
Height H	cm ²	ØD													
	40	170			675			725		830	860	910	1040	1050	1050
	80	170			675			725		830	860	910	1040	1050	1050
	160	225	695			745			850	880	930	1060	1070	1070	
	320	285	695			745			850	880	930	1060	1070	1070	
	640	320	735			785			890	920	970	1100	1110	1110	
Weight approx. kg															
cm ²	40/80	11	12	13	19	20	22	33	38	52	116	166	406	466	
	160	16	17	18	24	25	27	38	43	57	121	171	411	471	
	320	20	21	22	28	29	31	42	47	61	125	175	415	475	
	640	30	31	32	38	39	41	52	57	71	135	185	425	485	

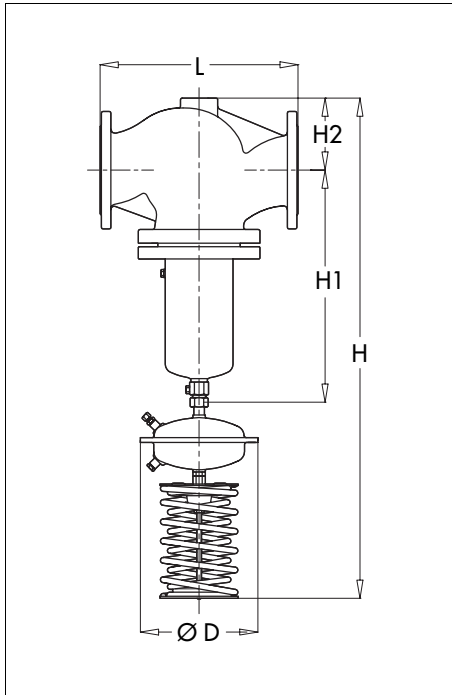

5. Customer inquiries

Should you have any inquiries, please submit the following details:

1. Type and nominal size of the excess pressure valve
2. Order and product number (written on the nameplate)
3. Upstream and downstream pressure
4. Process medium and flow rate in m³/h
5. Has a strainer been installed?
6. Installation drawing



SAMSON AG · MESS- UND REGELTECHNIK
 Weismüllerstraße 3 · D-60314 Frankfurt am Main
 Postfach 10 19 01 · D-60019 Frankfurt am Main
 Telefon (0 69) 4 00 90 · Telefax (0 69) 4 00 95 07

EB 2517-1 EN

S/C 04.98