

MOUNTING AND OPERATING INSTRUCTIONS



EB 3135-1 EN

Translation of original instructions



Pressure-independent Control Valve (PICV)
Type 2488/5xxx-x · Type 2488/TROVIS 5xxx-x
Flow regulator with electric actuator

Edition November 2024



Note on these mounting and operating instructions

These mounting and operating instructions assist you in mounting and operating the device safely. The instructions are binding for handling SAMSON devices. The images shown in these instructions are for illustration purposes only. The actual product may vary.

- For the safe and proper use of these instructions, read them carefully and keep them for later reference.
- If you have any questions about these instructions, contact SAMSON's After-sales Service (aftersaleservice@samsongroup.com).



Documents relating to the device, such as the mounting and operating instructions, are available on our website at www.samsongroup.com > **Downloads > Documentation.**

Definition of signal words

DANGER

Hazardous situations which, if not avoided, will result in death or serious injury

WARNING

Hazardous situations which, if not avoided, could result in death or serious injury

NOTICE

Property damage message or malfunction

Note

Additional information

Tip

Recommended action

1	Safety instructions and measures	5
1.1	Notes on possible severe personal injury	9
1.2	Notes on possible personal injury	10
1.3	Notes on possible property damage	11
2	Markings on the device	14
2.1	Nameplates	14
2.1.1	Nameplate for Type 2488 Valve	14
2.1.2	Electric actuator nameplate	14
2.2	Location of the nameplates	15
2.3	Material identification number	15
2.3.1	Type 2488 Valve	15
2.3.2	Electric actuator (with process controller)	15
3	Design and principle of operation	15
3.1	Technical data	17
4	Shipment and on-site transport	22
4.1	Accepting the delivered goods	22
4.2	Removing the packaging from the valve and actuator	22
4.3	Transporting and lifting the regulator	22
4.4	Storing the regulator	23
5	Installation	24
5.1	Preparation for installation	24
5.2	Installation conditions	25
5.3	Additional fittings	26
6	Start-up and operation	28
6.1	Start-up	28
6.1.1	Pipeline flushing	29
6.1.2	Installing the valve	29
6.1.3	Pressure test	29
6.1.4	Leakage	30
6.1.5	Mounting the actuator	30
6.1.6	Connecting the actuator	30
6.1.7	Configuring the actuator	30
6.1.8	Quick check	30

Contents

6.2	Operation	31
6.3	Starting up the plant.....	31
6.4	Adjusting the set points.....	32
6.4.1	Adjustment of the flow rate	32
6.4.2	Adjustment without electric actuator.....	32
6.4.3	Adjustment with electric actuator	33
6.4.4	Adjusting actuators without fail-safe action	33
6.4.5	Adjusting actuators with fail-safe action	34
7	Servicing.....	37
7.1	Replacing the electric actuator.....	39
7.2	Replacing the restriction.....	40
7.3	Replacing the seat and plug.....	42
7.4	Replacing the operating diaphragm	43
7.5	Tightening torques.....	44
7.6	Lubricants and sealants	45
7.7	Preparation for return shipment.....	45
7.8	Ordering spare parts and operating supplies	45
8	Malfunctions	46
9	Decommissioning and removal	48
9.1	Decommissioning.....	49
10	Disposal.....	49
11	Appendix.....	50
11.1	After-sales service	50
11.2	Certificates	50

1 Safety instructions and measures

Intended use

The Type 2488 Pressure-independent Control Valve (PICV) with an electric actuator is intended for flow control of liquids up to 150 °C and gases up to 80 °C. The pressure-independent control valves are mainly used in district heating supply networks. The regulator and actuator are designed to operate under exactly defined conditions (e.g. operating pressure, process medium, temperature). Therefore, operators must ensure that the valve and actuator are only used in operating conditions that meet the specifications used for sizing the devices at the ordering stage. In case operators intend to use the devices in applications or conditions other than those specified, contact SAMSON.

SAMSON does not assume any liability for damage resulting from the failure to use the device for its intended purpose or for damage caused by external forces or any other external factors.

➔ Refer to the technical data and nameplate for limits and fields of application as well as possible uses.

Reasonably foreseeable misuse

The device is not suitable for the following applications:

- Use outside the limits defined during sizing and by the technical data

Furthermore, the following activities do not comply with the intended use:

- Use of non-original spare parts
- Performing service and repair work not described
- Modification of parts as well as service or repair work on TÜV-tested Type 2488/5827-A and Type 2488/TROVIS 5725-x

Safety features

The Type 2488 Pressure-independent Control Valve (PICV) with an electric actuator without fail-safe action does not have any special safety features.

The Type 2488 Pressure-independent Control Valve (PICV) with an electric actuator with fail-safe action moves to a certain fail-safe position upon supply voltage failure. The fail-safe action of SAMSON actuators is specified on the actuator nameplate.

When relieved of pressure, the valve without actuator and with an open restriction is opened by the force of the compression springs.

Safety instructions and measures

Qualifications of operating personnel

The device must be mounted, started up, serviced and repaired by fully trained and qualified personnel only; the accepted industry codes and practices must be observed. According to these mounting and operating instructions, trained personnel refers to individuals who are able to judge the work they are assigned to and recognize possible hazards due to their specialized training, their knowledge and experience as well as their knowledge of the applicable standards.

Personal protective equipment

SAMSON recommends checking the hazards posed by the process medium being used (e.g.

▶ GESTIS (CLP) hazardous substances database).

- ➔ Provide protective equipment (e.g. safety gloves, eye protection) appropriate for the process medium used.
- ➔ Wear hearing protection when working near the valve. Follow the instructions given by the plant operator.
- ➔ Check with the plant operator for details on further protective equipment.

Revisions and other modifications

Revisions, conversions or other modifications of the product are not authorized by SAMSON. They are performed at the user's own risk and may lead to safety hazards, for example. Furthermore, the product may no longer meet the requirements for its intended use.

Warning against residual hazards

To avoid personal injury or property damage, plant operators and operating personnel must prevent hazards that could be caused in the regulator by the process medium, the operating pressure or by moving parts by taking appropriate precautions. Plant operators and operating personnel must observe all hazard statements, warnings and caution notes in these mounting and operating instructions, especially for installation, start-up and service work.

SAMSON also recommends checking the hazards posed by the process medium being used (e.g. ▶ GESTIS (CLP) hazardous substances database).

- ➔ Observe safety measures for handling the device as well as fire prevention and explosion protection measures.

Responsibilities of the operator

Operators are responsible for proper use and compliance with the safety regulations. Operators are obliged to provide these mounting and operating instructions as well as the referenced documents to the operating personnel and to instruct them in proper operation. Furthermore, operators must ensure that operating personnel or third parties are not exposed to any danger.

Operators are additionally responsible for ensuring that the limits for the product defined in the technical data are observed. This also applies to the start-up and shutdown procedures. Start-up and shutdown procedures fall within the scope of the operator's duties and, as such, are not part of these mounting and operating instructions. SAMSON is unable to make any statements about these procedures since the operative details (e.g. differential pressures and temperatures) vary in each individual case and are only known to the operator.

Responsibilities of operating personnel

Operating personnel must read and understand these mounting and operating instructions as well as the referenced documents and observe the specified hazard statements, warnings and caution notes. Furthermore, operating personnel must be familiar with the applicable health, safety and accident prevention regulations and comply with them.

Referenced standards, directives and regulations

The regulators comply with the requirements of the European Pressure Equipment Directive 2014/68/EU and the Machinery Directive 2006/42/EC. Regulators with a CE marking have a declaration of conformity which includes information about the applied conformity assessment procedure. This declaration of conformity is included in the Appendix of these instructions (see Chapter 11.2).

Non-electric valve versions whose bodies are not lined with an insulating material coating do not have their own potential ignition source according to the hazard assessment stipulated in Clause 5.2 of ISO 80079-36, even in the rare incident of an operating fault. Therefore, such valve versions do not fall within the scope of Directive 2014/34/EU.

→ For connection to the equipotential bonding system, observe the requirements specified in Clause 6.4 of EN 60079-14 (VDE 0165-1).

Referenced documents

The following documents apply in addition to these mounting and operating instructions:

- Mounting and operating instructions for
 - e.g. **Type 1 N or 1 NI Strainer** ▶ EB 1010
 - e.g. **Type 5827 Actuator (version with three-step signal)** ▶ EB 5827-1
 - e.g. **Type 5827 Actuator (version with positioner)** ▶ EB 5827-2
 - e.g. **Type 5857 Actuator** ▶ EB 5857
 - e.g. **TROVIS 5724-3 · TROVIS 5725-3 Actuators** ▶ EB 5724
 - e.g. **TROVIS 5724-8 and TROVIS 5725-8 Actuators** ▶ EB 5724-8
 - e.g. **TROVIS 5757-3 Actuator** ▶ EB 5757
 - e.g. **TROVIS 5757-7 Actuator** ▶ EB 5757-7
- Mounting and operating instructions as well as data sheets for additional components (e.g. shut-off valves, pressure gauges etc.).

1.1 Notes on possible severe personal injury

DANGER

Risk of fatal injury due to electric shock.

- Read and observe all notes on possible severe personal injury specified in the mounting and operating instructions of the electric actuator (with process controller).
- Before connecting wiring, performing any work on the device or opening the device, disconnect the supply voltage and protect it against unintentional reconnection.
- Only use power interruption devices that are protected against unintentional reconnection of the power supply.
- Do not remove any covers to perform adjustment work on live parts.
- Do not open the housing cover.
- The electric actuators are protected against spray water (IP 54). Avoid jets of water.

Risk of bursting in pressure equipment.

Valves and pipelines are pressure equipment. Improper opening can lead to device components bursting.

- Observe the maximum permissible pressure for regulator and plant.
- Before starting any work on the device, depressurize all plant sections affected as well as the valve.
- Drain the process medium from the plant sections affected as well as from the valve.
- If necessary, a suitable overpressure protection must be installed in the plant section.
- Wear personal protective equipment.

1.2 Notes on possible personal injury

WARNING

Damage to health relating to the REACH regulation.

If a SAMSON device contains a substance listed as a substance of very high concern on the candidate list of the REACH regulation, this is indicated on the SAMSON delivery note.

- Information on the safe use of the part affected. ► www.samsongroup.com/en/about-samson/material-compliance/reach-regulation/

Risk of personal injury due to residual process medium in the valve.

While working on the valve, residual medium can flow out of the valve and, depending on its properties, cause personal injury, e.g. (chemical) burns.

- If possible, drain the process medium from the plant sections affected and from the valve.
- Wear protective clothing, safety gloves and eye protection.

Risk of personal injury due to incorrect operation, use or installation as a result of information on the regulator being illegible.

Over time, markings, labels and nameplates on the regulator may become covered with dirt or become illegible in some other way. As a result, hazards may go unnoticed and the necessary instructions not followed. There is a risk of personal injury.

- Keep all relevant markings and inscriptions on the device in a constantly legible state.
- Immediately renew damaged, missing or incorrect nameplates or labels.

Risk of burn injuries due to hot or cold components and pipelines.

Depending on the process medium, valve components and pipelines may get very hot or cold and cause burn injuries.

- Allow components and pipelines to cool down or warm up to the ambient temperature.
- Wear protective clothing and safety gloves.

1.3 Notes on possible property damage

! NOTICE

Risk of valve damage due to contamination (e.g. solid particles) in the pipeline.

The plant operator is responsible for cleaning the pipelines in the plant.

→ Flush the pipelines before start-up.

Risk of valve damage due to unsuitable medium properties.

The valve is designed for process media with defined properties.

→ Only use process media specified for sizing the valve.

Risk of regulator damage due to the use of unsuitable lubricants.

The lubricants to be used depend on the regulator material. Unsuitable lubricants may corrode and damage surfaces.

→ Only use lubricants approved by SAMSON.
When in doubt, consult SAMSON.

Risk of leakage and regulator damage due to over- or under-torquing.

Observe the specified torques when tightening regulator components. Excessive tightening torques lead to parts wearing out more quickly. Parts that are too loose may cause leakage.

→ Observe the specified tightening torques (see Chapter 7.5).

Incorrect control due to the formation of ice on the regulator.

Medium temperatures below 0 °C may cause ice to form on the regulator, depending on the air humidity. This may affect, in particular, the functioning of the restriction stem guide.

→ Prevent the formation of ice by taking appropriate precautions (e.g. enclosure, trace heater etc.). The plant operator is responsible for selecting and implementing appropriate precautions.

! NOTICE

Risk of regulator damage due to the use of unsuitable tools.

Certain tools are required to work on the regulator.

- Only use tools approved by SAMSON.
When in doubt, consult SAMSON.

Risk of regulator damage due to incorrectly attached slings.

- Do not attach load-bearing slings to the actuator housing.

Risk of damage to the electric actuator (with process controller) due to over-torquing.

The connection of the electric actuator (with process controller) must be tightened with certain torques. Excessive tightening torques lead to parts wearing out more quickly.

- Read and observe the instructions and information specified in the mounting and operating instructions of the electric actuator (with process controller).

Risk of damage of the actuator with three-step control due to improper handling and incorrect operating conditions.

The electric actuator must only be used for its intended use.

- Read and observe all notes on possible property damage specified in the mounting and operating instructions of the electric actuator (with process controller).

Manipulation of settings at the electric actuator with process controller due to unauthorized access.

The electric actuator with process controller has a communication interface for data transmission with the TROVIS-VIEW software (firmware 1.1x: Bluetooth®, firmware 2.1x: Modbus RTU). The communication interface is active in the delivered state of the electric actuator with process controller.

- When data transmission is not used, deactivate the communication interface with the operating keys or by setting the 'Protocol' parameter to 'None'.
- Read and observe the instructions and information specified in the mounting and operating instructions of the electric actuator with process controller.

! NOTICE

Risk of damage to the screw heads on the front housing cover due to the use of the wrong tool.

The front housing cover of the electric actuator is fastened using TORX PLUS® screws, size 10IP.

→ To loosen and tighten the screws, only use the following screwdrivers:

- TORX® T10
- TORX PLUS® 10IP
- Flat-blade screwdriver with 0.8 mm blade thickness and 4.0 mm blade width

i Note

SAMSON's After-sales Service can support you concerning lubricant, tightening torques and tools approved by SAMSON.

2 Markings on the device

Several nameplates are affixed to the device. The nameplates shown were up to date at the time of publication of this document. The nameplates on the device may differ from

the ones shown. The nameplates are used to identify the separate regulator components (see Chapter 2.1).

2.1 Nameplates

2.1.1 Nameplate for Type 2488 Valve

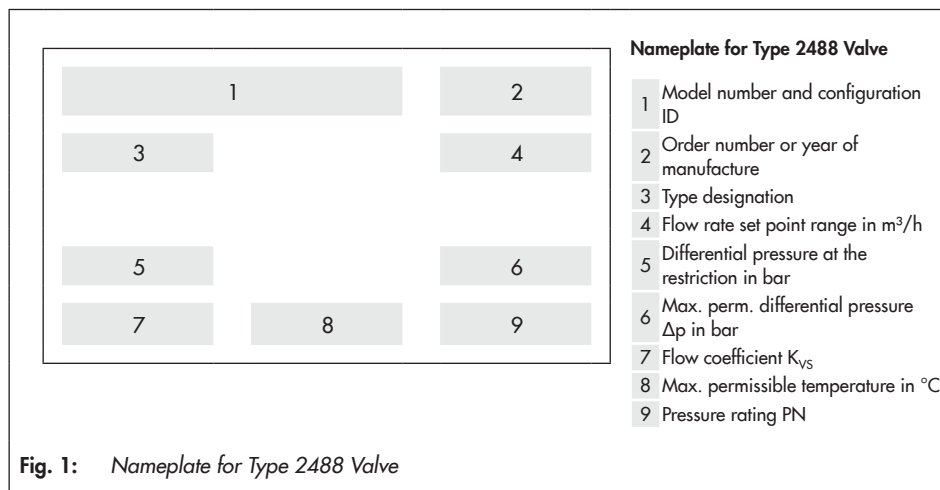

2.1.2 Electric actuator nameplate

See associated actuator documentation.

2.2 Location of the nameplates

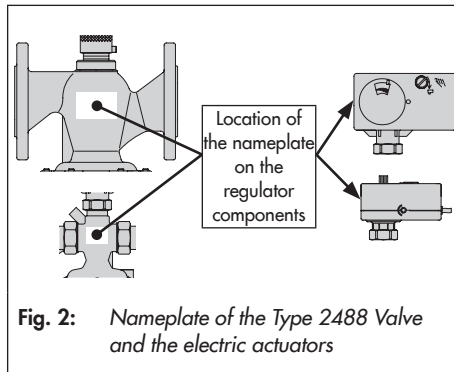

2.3 Material identification number

2.3.1 Type 2488 Valve

The material designation can be found on the cast body or you can contact us (the configuration ID specification is needed) to find out which material is used. For more details on the nameplate, see Chapter 2.1.

2.3.2 Electric actuator (with process controller)

Specifying the configuration ID, you can contact us to find out which material is used. See associated actuator documentation for more details on the nameplate.

3 Design and principle of operation

→ See Fig. 3

The pressure-independent control valve (PICV) consists of the Type 2488 Valve and an electric actuator. The valve is fitted with a connecting piece for connection of an electric actuator. As a result, it is possible to transmit the control signal of an electric control device to achieve additional temperature control by changing the restriction position. A maximum flow rate can be adjusted mechanically at the restriction (orifice). The medium flows through the valve in the direction indicated by the arrow on the valve body. The flow rate is determined by the area released by the restriction (8.5) and the plug (3).

The installed set point spring (5) determines the differential pressure across the restriction of 0.2 bar. The pressure upstream of the restriction (8.5) is transmitted over the control line (7) to the upstream pressure side of the actuator. The pressure downstream of the restriction acts on the low-pressure side of the operating diaphragm (6.1) through a hole in the plug. The differential pressure generated across the restriction is converted into a positioning force by the operating diaphragm. This force is used to move the plug depending on the force of the set point spring (5). The flow rate is adjusted at the adjusting screw (8.3) or set point adjuster (8.2).

Design and principle of operation

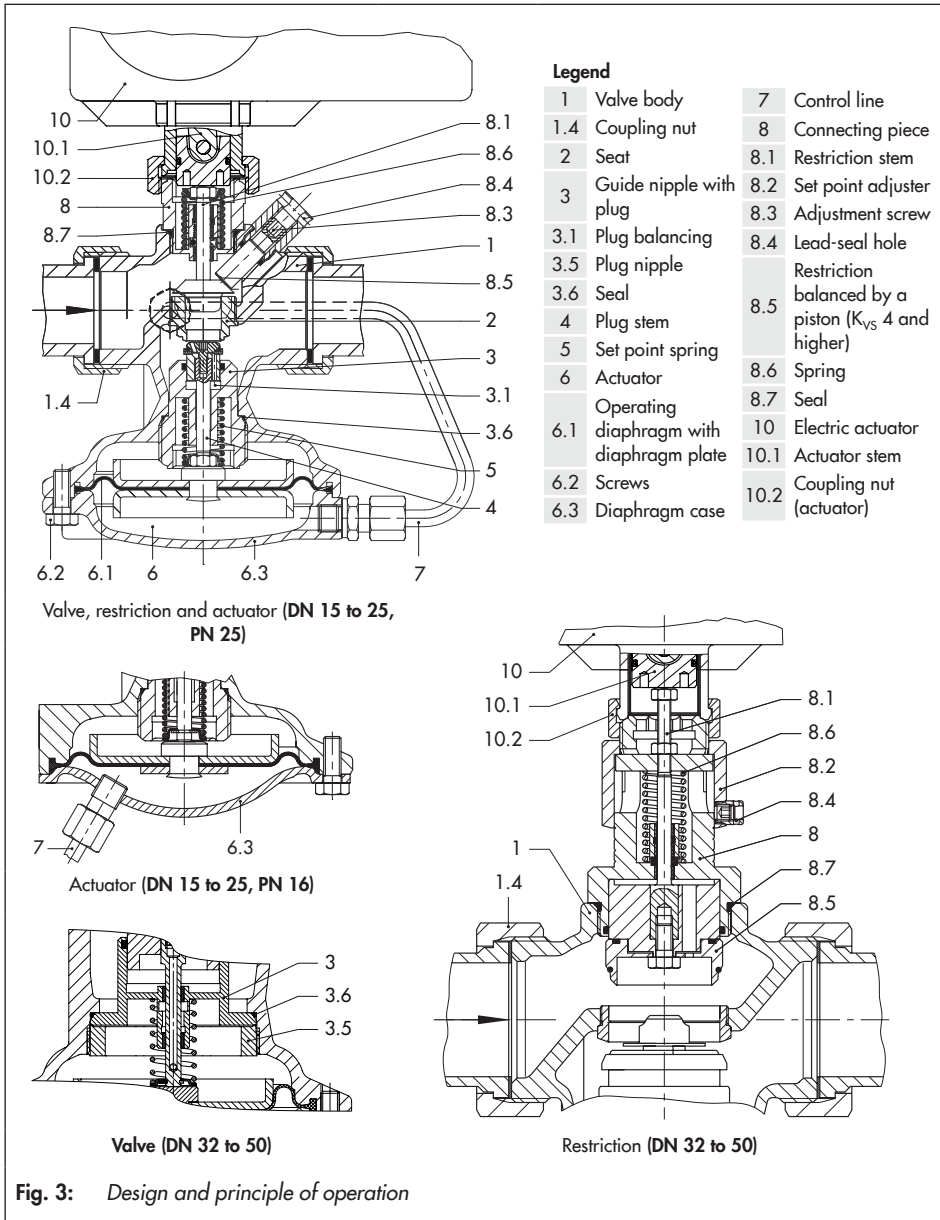

3.1 Technical data

The nameplate on the regulator contains information on the regulator version (see Chapter 2.1).

i Note

More information is available in Data Sheet
▶ T 3135.

Process medium and scope of application

The **Type 2488/5xxx** and **Type 2488/TROVIS 5xxx** Pressure-independent Control Valves (PICV) are used to control the flow rate and temperature in district heating systems or extended heating or cooling networks.

- Suitable for **water** and **non-flammable gases**.
- Non-flammable gases up to **80 °C**
- Liquids up to **150 °C**
- Permissible ambient temperature **0** to **50 °C**

The regulators are open when relieved of pressure. They close (provided the restriction has not been closed manually) depending on the output signal issued by the electric control device.

Conformity

The Type 2488/5xxx and Type 2488/TROVIS 5xxx Regulator bears both the CE and EAC marks of conformity.



Temperature range

The Type 2488/5xxx and 2488/TROVIS 5xxx Regulators are designed for a temperature range from -10 to $+150$ °C.

Leakage class

The metal-seated regulator has the leakage class **I** according to IEC 60534-4.

The soft-seated regulator has the leakage class **IV** according to IEC 60534-4.

Noise emissions

SAMSON is unable to make general statements about noise emissions. The noise emissions depend on the valve version, plant facilities and process medium.

⚠ WARNING

Risk of hearing loss or deafness due to loud noise.

➔ *Wear hearing protection when working near the valve. Follow the instructions given by the plant operator.*

i Note

The Type 2488/5xxx and Type 2488/TROVIS 5xxx Pressure-independent Control Valve (PICV) are not safety valves. If necessary, a suitable overpressure protection must be installed on site in the plant section.

Dimensions and weights

Table 3 provides a summary of the dimensions and weights of the Type 2488/5xxx and 2488/TROVIS 5xxx Regulators. The lengths and heights in Fig. 4 are shown on page 21.

Design and principle of operation

Table 1: Technical data · Valve · All pressures in bar (gauge)

Leakage class according to IEC 60534-4	I: ≤ 0.05 % of K_{VS} coefficient (restriction with metal seal) IV: ≤ 0.01 % of K_{VS} coefficient (restriction with soft seal)					
Max. permissible temperature	For liquids 130 °C (PN 16)/150 °C ⁵⁾ (PN 25) For air and non-flammable gases 80 °C					
Conformity	CE · EAC					
Nominal size, body with screwed ends	DN 15/20/25		DN 15	DN 20	DN 25	
Pressure rating	PN 16/PN 25					
K_{VS} coefficient	0.4 ¹⁾	1.0 ¹⁾	2.5	4.0 ¹⁾	6.3	8.0
x_{FZ} value	0.6					
Restriction	Balancing		None			
	Seal	Metal	Soft	Metal		
Max. perm. differential pressure Δp across the valve	10 bar ³⁾ /20 bar					
Flow rate set point ranges for water in m³/h						
Flow set point range/limitation for water with 0.2 bar diff. press. at restriction	0.03 to 0.2	0.12 to 0.64	0.2 to 1.2	0.6 to 1.3 ⁶⁾ 0.6 to 2.5	0.8 to 2.3 ⁶⁾ 0.8 to 3.6	0.8 to 3.5 ⁶⁾ 0.8 to 4.2 ⁴⁾
Nominal size DN	32		40		50	
Pressure rating	PN 25					
K_{VS} coefficient	Body with screwed ends	12.5		16.0		20.0
	Flanged valve body ²⁾	12.5		20.0		25.0
x_{FZ} value	Body with screwed ends	0.5				0.45
	Flanged valve body ²⁾	0.45				0.4
Restriction	Balancing		Balanced by a piston			
	Seal		Soft			
Max. permissible differential pressure Δp across the valve	20 bar			16 bar		
Flow rate set point ranges for water in m³/h						
Flow rate set point range/limitation for water with 0.2 bar differential pressure at the restriction	2 to 5.8 ⁶⁾ 2 to 10		3 to 9.1 ⁶⁾ 3 to 12.5		4 to 14.1 ⁶⁾ 4 to 15	

¹⁾ Special version

²⁾ Body: spheroidal graphite iron EN-GJS-400-18-LT

³⁾ For PN 16 version

⁴⁾ 5 m³/h with 0.3 bar differential pressure at the restriction (special version)

⁵⁾ With intermediate insulating piece (item number 1992-3132)

⁶⁾ An increase in noise level can be expected when the specified flow rates are exceeded, even if cavitation does not occur (see AGFW (German District Heating Association) document FW 514).

Table 2: *Materials · Material numbers according to DIN EN*

Body		Red brass CC499K (Rg 5) · Spheroidal graphite iron EN-GJS-400-18-LT ¹⁾
Seat		Stainless steel 1.4305
Plug	PN 25	Brass, resistant to dezincification, with EPDM soft seal ²⁾
	PN 16	Brass, resistant to dezincification and plastic with EPDM soft seal
Diaphragm case	PN 25	Red brass CC499K (Rg 5) · Spheroidal graphite iron EN-GJS-400-18-LT ¹⁾
	PN 16	Stainless steel 1.4301
Valve spring		Stainless steel 1.4310
Restriction		Brass, free of dezincification
Operating diaphragm		EPDM ²⁾ with fabric reinforcement
Seals		EPDM ²⁾

¹⁾ Additional version in DN 32 to 50: valve with flanged body made of spheroidal graphite iron

²⁾ Special version, e.g. for mineral oils: FKM

NOTICE

- The technical data of the TROVIS 57xx and Type 58xx Electric Actuators are listed in the actuator documentation ('Referenced documents' on page 8).
- The technical data of the Type 2430 Control Thermostat are listed in the associated documentation ('Referenced documents' on page 8).

Design and principle of operation

Table 3: Dimensions and weights in kg

Nominal size		DN 15	DN 20	DN 25	DN 32 ¹⁾	DN 40 ¹⁾	DN 50 ¹⁾
Pipe Ø d	mm	21.3	26.9	33.7	42.4	48.3	60.3
Thread size R		G ¾	G 1	G 1¼	G 1¾	G 2	G 2½
Width across flats (A/F)	mm	30	36	46	59	65	82
Length L	mm	65	70	75	100	110	130
Height H	mm	155 · 158 ³⁾			216 · 219 ³⁾		
Height H3	mm	122			-		
Height H1	mm	85			105	140	
Version with welding ends							
Length L1	mm	210	234	244	268	294	330
Weight, kg (approx.)		3.0	3.1	3.2	4.4	6.9	7.4
Special versions							
With threaded ends							
Length L2	mm	129	144	159	192	206	228
Male thread A		G ½	G ¾	G 1	G 1¼	G 1½	G 2
Weight, kg (approx.)		3.0	3.1	3.2	4.4	6.9	7.4
With screwed-on flanges ²⁾ (PN 16/25) or with flanged body (DN 32 to 50)							
Length L3	mm	130	150	160	180	200	230
Weight, kg (approx.)		4.4	5.1	5.7	7.6	10.9	12.4

¹⁾ Additional version: valve with flanged body

²⁾ Flanges are already mounted on valves in DN 40 and 50

³⁾ for Type 5827-... Actuator

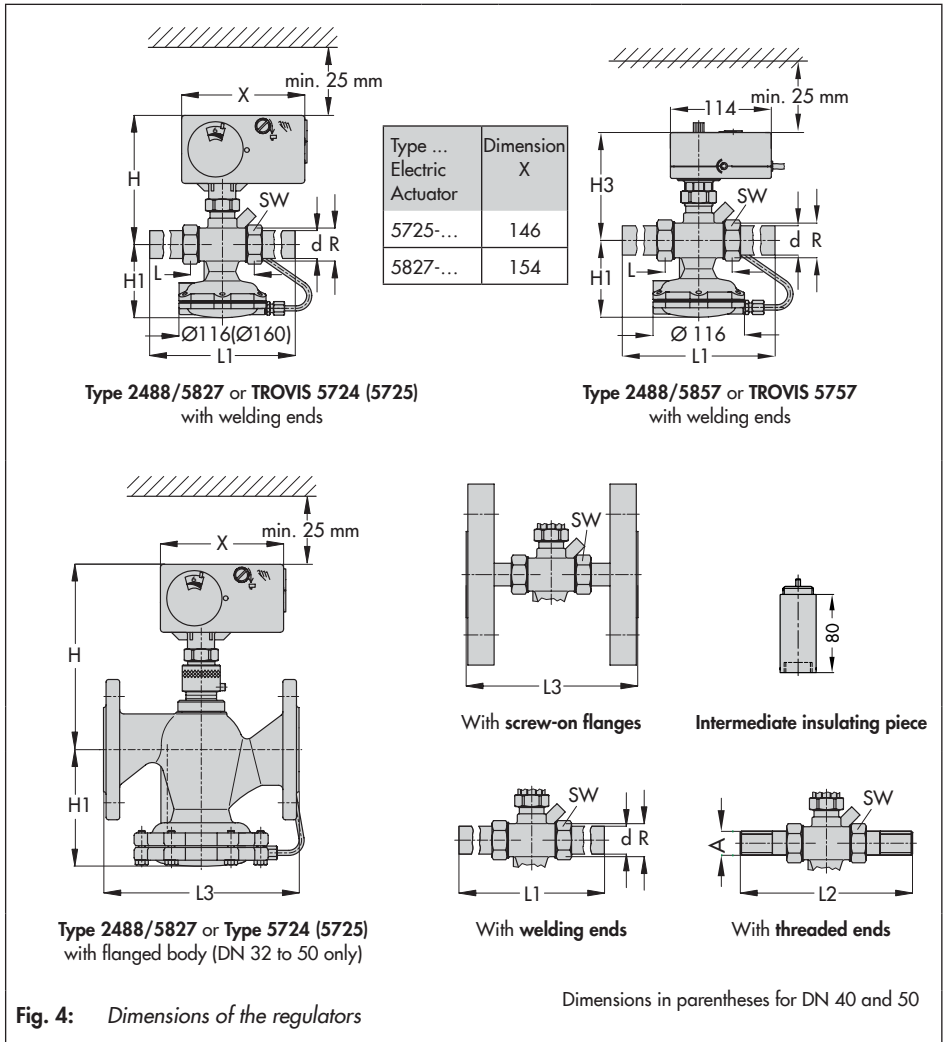

4 Shipment and on-site transport

The work described in this chapter is to be performed only by personnel appropriately qualified to carry out such tasks.

4.1 Accepting the delivered goods

After receiving the shipment, proceed as follows:

1. Check the scope of delivery. Check that the specifications on the valve and actuator nameplate match the specifications in the delivery note. See Chapter 2.1 for more details on the nameplate.
2. Check the shipment for transportation damage. Report any damage to SAMSON and the forwarding agent (refer to delivery note).

4.2 Removing the packaging from the valve and actuator

NOTICE

Risk of regulator damage due to foreign particles entering the valve.

The protective caps fitted on the inlet and outlet of the valve with flanged body prevent foreign particles from entering the valve and damaging it.

Do not remove the protective caps until immediately before installation.

Note

Do not remove the packaging until immediately before installation.

The components (valve and electric actuator) of the regulator are delivered separately.

Proceed as follows to install the regulator:

- Do not open or remove the packaging until immediately before lifting to install the regulator into the pipeline.
- Leave the regulator components in its transport container or on the pallet to transport it on site.
- Do not remove the protective caps from the inlet and outlet until immediately before installing the valve into the pipeline. They prevent foreign particles from entering the valve.
- Dispose and recycle the packaging in accordance with the local regulations.

4.3 Transporting and lifting the regulator

Due to the low service weight, lifting equipment is not required to lift and transport the regulator (e.g. to install it into the pipeline).

Transport instructions

- Protect the regulator against external influences (e.g. impact).
- Do not damage the corrosion protection (paint, surface coatings). Repair any damage immediately.

- Protect the regulator against moisture and dirt.
- Protect the piping and any mounted valve accessories against damage.
- Do not use the attached control lines to lift or carry the regulator.
- Observe the permissible ambient temperatures (see Chapter 3.1).

4.4 Storing the regulator

NOTICE

Risk of regulator damage due to improper storage.

- Observe the storage instructions.
- Avoid longer storage periods.
- Contact SAMSON in case of different storage conditions or longer storage times.

Note

SAMSON recommends to regularly check the regulator and the prevailing storage conditions during long storage periods.

Storage instructions

- Protect the regulator against external influences (e.g. impact).
- Secure the regulator in the stored position against slipping or tipping over.
- Do not damage the corrosion protection (paint, surface coatings). Repair any damage immediately.

- Protect the regulator against moisture and dirt. Store it at a relative humidity of less than 75 %. In damp spaces, prevent condensation. If necessary, use a drying agent or heating.
- Make sure that the ambient air is free of acids or other corrosive media.
- Observe the permissible ambient temperatures (see Chapter 3.1).
- Do not place any objects on the regulator.

Special storage instructions for elastomers

Elastomer, e.g. operating diaphragm

- To keep elastomers in shape and to prevent cracking, do not bend them or hang them up.
- Store elastomers away from lubricants, chemicals, solutions and fuels.
- SAMSON recommends a storage temperature of 15 °C for elastomers.

Tip

Our after-sales service can provide more detailed storage instructions on request.

5 Installation

→ See Fig. 3

The work described in this chapter is to be performed only by personnel appropriately qualified to carry out such tasks.

Valve and electric actuator can be assembled before or after the valve has been installed in the pipeline. SAMSON recommends first installing the valve without the electric actuator into the pipeline.

5.1 Preparation for installation

Valve and actuator can be assembled before or after the valve has been installed in the pipeline. SAMSON recommends first installing the valve without the actuator into the pipeline.

Before installation, make sure the following conditions are met:

- The valve is clean.
- The valve, actuator and all piping are not damaged.
- Install a strainer upstream of the regulator.
- The valve data on the nameplate (type designation, nominal size, material, pressure rating and temperature range) match the plant conditions (nominal size and pressure rating of the pipeline, medium temperature etc.). See Chapter 2.1 for more details on the nameplate.
- The requested or required additional pipe fittings (see Chapter 5.3) have been installed or prepared as necessary before installing the valve.

Proceed as follows:

- Lay out the necessary material and tools to have them ready during installation work.
- Flush the pipeline **before** installing the regulator (see Chapter 6.1).
The plant operator is responsible for cleaning the pipelines in the plant.
- Check any mounted pressure gauges to make sure they function properly.

i Note

The plant operator is responsible for cleaning the pipelines in the plant.

i Note

Any impurities carried along by the process medium may impair the proper functioning of the regulator. Therefore, SAMSON recommends installing a strainer (e.g. SAMSON Type 1 NI) upstream of the regulator (see Chapter 5.3).

5.2 Installation conditions

Work position

The work position for the regulator is the front view onto all operating controls on the regulator (including any additional fittings) seen from the position of operating personnel.

Plant operators must ensure that, after installation of the device, the operating personnel can perform all necessary work safely and easily access the device from the work position.

Make sure the following conditions are met:

- ➔ Install a strainer upstream of the regulator (see Chapter 5.3).
- ➔ Make sure the direction of flow matches the direction indicated by the arrow on the body.
- ➔ Install the regulator free of stress.
- ➔ On insulating the valve, do not insulate the actuator and the coupling nut as well. Make sure the permissible ambient temperature is not exceeded, especially at the actuator stem (10.1). If necessary, an intermediate insulating piece (order no. 1992-3132) must be used. The insulating limit is in this case approx. 25 mm above the top of the valve body.
- ➔ Observe the minimum differential pressure of the plant (see Table 1).

The minimum differential pressure is calculated from:

$$\Delta p_{\min} = \text{Differential pressure across restriction} \\ \Delta p_{\text{restriction}} + (\dot{V}/K_{VS})^2$$

Δp_{\min}	Minimum differential pressure across the valve in bar
$\Delta p_{\text{restriction}}$	Differential pressure created at the restriction for measuring the flow rate in bar
\dot{V}	Flow rate, adjusted in m ³ /h
K_{VS}	Valve flow coefficient in m ³ /h

! NOTICE

Possible malfunction and damage due to adverse weather conditions (temperature, humidity).

- Do not install the regulator outdoors or in rooms prone to frost.
- Protect the regulator against frost if it is used to control freezing media.
- Either heat the regulator or remove it from the plant and completely drain the residual medium.

Mounting orientation

To ensure that the regulator functions properly, proceed as follows:

- ➔ For regulators **DN 15 to 25**:
Installation into **horizontal** and **vertical** pipes.
- ➔ For regulators **DN 32 to 50**:
Install the regulators in **horizontal** pipelines.

Installation

- The electric actuator **must** be mounted above the valve body.

Pipeline routing

The inlet and outlet lengths vary depending on the process medium and the flow conditions in the valve. To ensure the regulator functions properly, follow the installation instructions given below:

- Observe the inlet and outlet lengths (see Table 4). Contact SAMSON if the valve conditions or states of the medium process deviate.
- Install the regulator free of stress and with the least amount of vibrations as possible. If necessary, attach supports to the valve.
- Install the regulator allowing sufficient space to remove the electric actuator and valve or to perform service and repair work on them.

Support and suspension

i Note

The plant engineering company is responsible for selecting and implementing a suitable support or suspension of the installed regulator and the pipeline.

Depending on the regulator version and mounting position, the regulator and pipeline must be supported or suspended.

! NOTICE

Do not attach supports directly to the valve or actuator.

5.3 Additional fittings

Strainers

A strainer (see Fig. 5) installed upstream in the flow pipe holds back any dirt or other foreign particles carried along by the medium. For example, the SAMSON Type 1 NI Strainer is suitable (▶ T 1010).

- Install the strainer upstream of the regulator.
- Make sure the direction of flow matches the direction indicated by the arrow on the body.
- Install the strainer with the filter element facing downward.
- Allow sufficient space to remove the filter.

Shut-off valve

Install a hand-operated shut-off valve both upstream of the strainer and at the outlet of the return flow pipe (see Fig. 5). This allows the plant to be shut down for cleaning and maintenance, and when the plant is not used for longer periods of time.

Pressure gauge

Install a pressure gauge at a suitable point to monitor the pressures prevailing in the plant (see Fig. 5).

Table 4: Inlet and outlet lengths

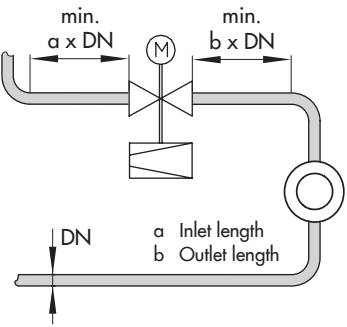
	State of process medium	Valve conditions	Inlet length a	Outlet length b
	Gas	$Ma \leq 0.3$	2	4
	Liquid	Free of cavitation $w < 3 \text{ m/s}$	2	4
		Cavitation producing noise $w \leq 3 \text{ m/s}$	2	4

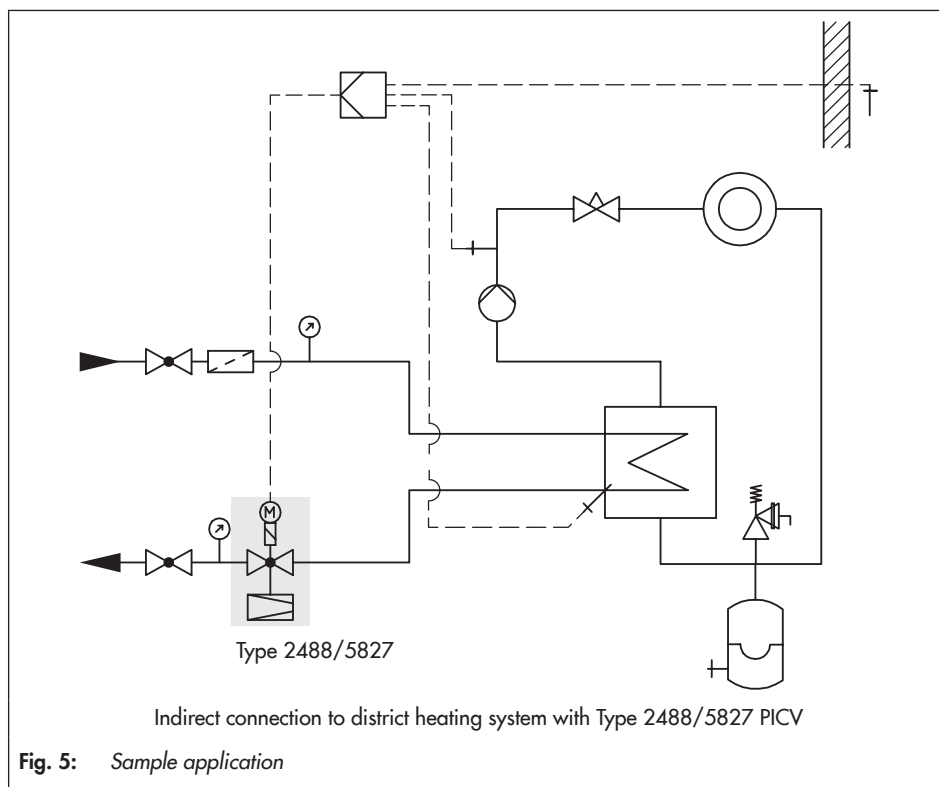

Fig. 5: Sample application

6 Start-up and operation

→ See Fig. 3

6.1 Start-up

⚠ DANGER

Risk of fatal injury due to electric shock.

- Do not remove any covers to perform adjustment work on live parts.
 - Before performing any work on the device and before opening the device, disconnect the supply voltage and protect it against unintentional reconnection.
 - Only use power interruption devices that are protected against unintentional reconnection of the power supply.
 - The electric actuators are protected against spray water (IP 54). Avoid jets of water.
-

⚠ DANGER

Risk of bursting in pressure equipment.

Valves and pipelines are pressure equipment. Improper opening can lead to device components bursting.

- Before starting any work on the device, depressurize all plant sections affected as well as the valve.
 - Drain the process medium from the plant sections affected as well as from the valve.
 - If necessary, a suitable overpressure protection must be installed in the plant section.
 - Wear personal protective equipment.
-

⚠ DANGER

Risk of personal injury due to process medium escaping.

- Do not start up the regulator until all parts have been mounted.
-

⚠ WARNING

Risk of personal injury due to pressurized components and the operating medium being released.

- Do not unscrew the control line while the valve is pressurized.
-

⚠ WARNING

Risk of burn injuries due to hot or cold components and pipeline.

Regulator components and the pipeline may become very hot or cold. Risk of burn injuries.

- Allow components and pipelines to cool down or warm up to the ambient temperature.
 - Wear protective clothing and safety gloves.
-

Before start-up or putting the device back into service, make sure the following conditions are met:

- The regulator is properly installed in the pipeline (see Chapter 5).
- The leak and function tests have been completed successfully.

The prevailing conditions in the plant section affected meet the regulator sizing require-

ments (see section 'Intended use' on page 5).

6.1.1 Pipeline flushing

SAMSON recommends additionally flushing the pipeline with installed regulator before start-up.

Rinsing the plant

1. After filling the plant, first completely open the consumer.
2. Adjust the maximum flow rate at the regulator (see Chapter 6.4).
3. Rinse out the pipeline at full flow rate for several minutes.
4. Check the strainer (e.g. measure the pressure drop) and clean it, if necessary.

6.1.2 Installing the valve

→ See Fig. 3

1. Close the shut-off valves in the pipeline while the valve is being installed.
2. Remove the protective caps from the valve ports, if fitted, before installing the valve.
3. Install the valve into the pipeline. The arrow on the valve indicates the direction of flow.
4. Make sure that the correct gaskets are used.
5. Bolt the pipe to the valve free of stress.

6.1.3 Pressure test

All plant components must be designed for the test pressure.

Observe the following on pressure testing the regulator:

- Remove the regulator from the pipeline for pressure testing the plant.
- OR**
- Fully open the restriction of an installed regulator before pressure testing the plant.
 - Open the shut-off valves slowly preferably starting from the upstream pressure side (to allow the plant to fill gradually over a few minutes).

! NOTICE

Risk of valve damage due to a sudden pressure increase and resulting high flow velocities.

– *Slowly open the shut-off valves.*

! NOTICE

Risk of damage to the regulator due to impermissible excess pressure.

The test pressure must not exceed the pressure rating by 1.5 times on testing the pressure of the plant when the regulator is installed. Do not pressurize the diaphragm from one side.

i Note

The plant operator is responsible for performing the pressure test. SAMSON's

After-sales Service can support you to plan and perform a pressure test for your plant.

6.1.4 Leakage

The plant operator is responsible for performing the leak test and selecting the test method. The leak test must comply with the requirements of the national and international standards that apply at the site of installation.



Tip

Our after-sales service can support you to plan and perform a leak test for your plant.

1. Slowly open the shut-off valve installed upstream of the regulator.
2. Apply the required test pressure.
3. Check the regulator for leakage to the atmosphere.
4. Depressurize the pipeline section and valve.
5. Rework any parts that leak and repeat the leak test.

6.1.5 Mounting the actuator

→ See Fig. 3

1. Place the electric actuator (10) onto the connecting piece (8) of the valve and fasten with the coupling nut (10.2). Observe the tightening torques specified in Chapter 7.5.
2. Connect the supply voltage to the electric actuator (see Chapter 6.1.6).

6.1.6 Connecting the actuator

Connection of the electric actuator to the supply voltage is described in the associated mounting and operating instructions of the electric actuator. See associated actuator documentation.

6.1.7 Configuring the actuator

The electric actuator versions with positioner as well as electric actuators with process controller can be adapted to the control task. Configure the actuator as described in the associated actuator documentation.

i Note

For electric control valves with positioner, an initialization needs to be performed after the initial start-up (see associated actuator documentation).

6.1.8 Quick check

The Type 2488 Valve combined with an electric actuator with fail-safe action (Type 5x25-x and TROVIS 5x25-x) is certified as DIN tested according to DIN EN 14597.

SAMSON valves are delivered ready for use. To test the valve's ability to function, the following quick checks can be performed:

Travel motion

The movement of the actuator stem must be linear and smooth.

- Open and close the valve again. Open and close the valve, observing the movement of the actuator stem.
- Apply the maximum and minimum control signals to check the end positions of the valve.
- Check the travel reading at the travel indicator scale.

Fail-safe position for electric actuators and electric actuators with process controller with fail-safe action

- Switch off the supply voltage.
- Check whether the valve moves to the fail-safe position.

6.2 Operation

The regulator is ready for use when mounting and start-up have been completed.

⚠ WARNING

Risk of burn injuries due to hot components and pipelines.

Valve components and pipelines may get very hot and cause burn injuries. Wear protective clothing and safety gloves.

6.3 Starting up the plant

- See Fig. 3
- Do not start up the regulator until all parts have been mounted.

- Make sure that the restriction (8.5) is open while filling the plant. To do so, de-energize the electric actuator (10) and turn the handwheel on the actuator counterclockwise (↺) as far as it will go.

i Note

The restriction in electric actuators with fail-safe action is automatically closed when the supply voltage is disconnected.

- When an electric actuator with fail-safe action is mounted, open the restriction manually or electrically.

i Note

Refer to the mounting and operating instructions of the electric actuator for more details. See information under 'Referenced documents' on page 8.

- Open the shut-off valves slowly over a time period of several minutes starting from the upstream pressure side. Afterwards, open all the valves on the consumer side (downstream of the regulator).
- Adjust the set point (see Chapter 6.4).

⚠ NOTICE

Risk of valve damage due to a sudden pressure increase and resulting high flow velocities.

Slowly open the shut-off valve in the pipeline during start-up.

Note

To open the restriction, de-energize electric actuators with fail-safe action and remove them from the valve.

6.4 Adjusting the set points

→ (see Fig. 3)

The flow rate can be adjusted either when the electric actuator is mounted on the valve or without a mounted electric actuator.

6.4.1 Adjustment of the flow rate

→ Completely open the control and shut-off valves or the bypass valve in the plant.

To adjust or change the flow rate set point, proceed as follows:

Always adjust the set point based on a completely closed restriction.

NOTICE

Risk of damage to the restriction stem through one-side loading (DN 15 to 25) while turning the adjustment screw clockwise.

First turn the handwheel of the electric actuator or using the manual adjuster Ba43 (▶ T 2176, 1790-8169) to completely close the restriction.

Tip

For exact adjustment, verify adjusted value with a heat or flow meter.

6.4.2 Adjustment without electric actuator

For valve sizes DN 15 to 25, adjust the flow rate by turning the adjustment screw (8.3) at the side using a 4 mm hex wrench.

For valve sizes DN 32 to 50, use the set point adjuster (8.2) to adjust the flow rate.

NOTICE

For valve sizes DN 15 to 25, use the manual adjuster Ba43 (▶ , 1790-8169) to close the restriction. Do not use the side adjustment screw (8.3) to close the restriction. After reaching the closed position, fix this position with the side adjustment screw (8.3) and remove the manual adjuster Ba43. Adjust the flow rate at the adjustment screw (8.3).

1. Close the restriction by:
 - Turning the set point adjuster (8.2) clockwise or
 - Extending the stem of the electric actuator or
 - Using the manual adjuster Ba43.
- For valve sizes DN 15 to 25, the regulator is delivered with an open restriction (8.5).

2. Determine the number of turns required to achieve the desired flow set point from the relevant adjustment diagram.
For nominal size DN 15, the adjustment curve that corresponds with the flow coefficient K_{vs} indicated on the nameplate must be selected.
3. Based on a closed restriction (screw/adjuster turned clockwise as far it will go), adjust the flow set point by turning the screw or adjuster counterclockwise. Check the flow rate and correct it, if necessary.
4. Guide the wire through the lead-seal hole and lead-seal it to fix the adjusted flow rate.

6.4.3 Adjustment with electric actuator

NOTICE

The electric actuators are designed for use in low voltage installations. For wiring and maintenance, you are required to observe the relevant safety regulations. Only use power interruption devices that are protected against unintentional reconnection of the power supply. Do not remove any covers to perform adjustment work on live parts.

6.4.4 Adjusting actuators without fail-safe action

WARNING

Observe the relevant safety regulations on mounting or removing the electric actuator.

1. Extend the actuator stem (10.1) by turning the handwheel counterclockwise or by applying a corresponding control signal from the control device.
2. Use a suitable tool (Allen key, SW 4) to turn the adjustment screw (8.3) or the set point adjuster (8.2) clockwise (↻) as far as it will go to retract the stem of the electric actuator.
3. Refer to Fig. 6 or Fig. 7 to find out how many turns are required to set the flow rate.
4. Use a suitable tool (Allen key, SW 4) to turn the adjustment screw (8.3) or the set point adjuster (8.2) by the required number of turns.
Turn it counterclockwise (↺) to open the restriction. The flow rate rises.
5. Guide the wire through the lead-seal hole and lead-seal it to fix the adjusted flow rate.

6.4.5 Adjusting actuators with fail-safe action

WARNING

Observe the relevant safety regulations on mounting or removing the electric actuator.

The restriction in electric actuators with fail-safe action is automatically closed when the supply voltage is disconnected.

The actuator can be moved over the manual override when no control signal is available. In this case, remove the front housing cover, place a 4 mm Allen key on the red actuating shaft and turn it counterclockwise. Turn the Allen key only to the point where the torque switch in the actuator is activated.

Once the magnet has been released, the spring mechanism pushes the actuator stem back to the fail-safe position.

1. Switch the control device to manual mode and change the control signal to retract the actuator stem all the way and compress the spring mechanism.
2. Use a suitable tool (Allen key, SW 4) to turn the adjustment screw (8.3) or the set point adjuster (8.2) clockwise (↻) as far as it will go.
3. Refer to Fig. 6 or Fig. 7 to find out how many turns are required to set the flow rate.
4. Use a suitable tool (Allen key, SW 4) to turn the adjustment screw (8.3) or the set point adjuster (8.2) by the required number of turns.

Turn it counterclockwise (↺) to open the restriction. The flow rate rises.

5. Guide the wire through the lead-seal hole and lead-seal it to fix the adjusted flow rate.

Note

*The flow rate indicated in the diagram is reduced by approximately 20 % for valves in sizes **DN 32 to 50** which are combined with **Type 5821/5822 Actuators**.*

Table 5: K_{VS} coefficients and flow rates

Nominal size	DN 15				DN 20	DN 25	DN 32	DN 40 ¹⁾	DN 50 ¹⁾	
K_{VS} coefficient	0.4	1	2.5	4	6.3	8	12.5	16/20 ³⁾	16/25 ³⁾	
Set point range in m ³ /h with 0.2 bar diff. pressure at the restriction $\Delta p_{restriction}$	-				0.6 to 1.3 ²⁾	0.8 to 2.3 ²⁾	0.8 to 3.5 ²⁾	2 to 5.8 ²⁾	3 to 9.1 ²⁾	4 to 14.1 ²⁾
	0.03 to 0.2	0.1 to 0.64	0.2 to 1.2	0.6 to 2.5	0.8 to 3.6	0.8 to 4.2 ⁴⁾	2 to 10	3 to 12.5	4 to 15	

1) Version with flanged valve body

2) An increase in noise level can be expected when the specified flow rates are exceeded.

3) K_{VS} coefficient with flanged valve body

4) 5 m³/h with 0.3 bar differential pressure at the restriction ($\Delta p_{restriction}$, special version)

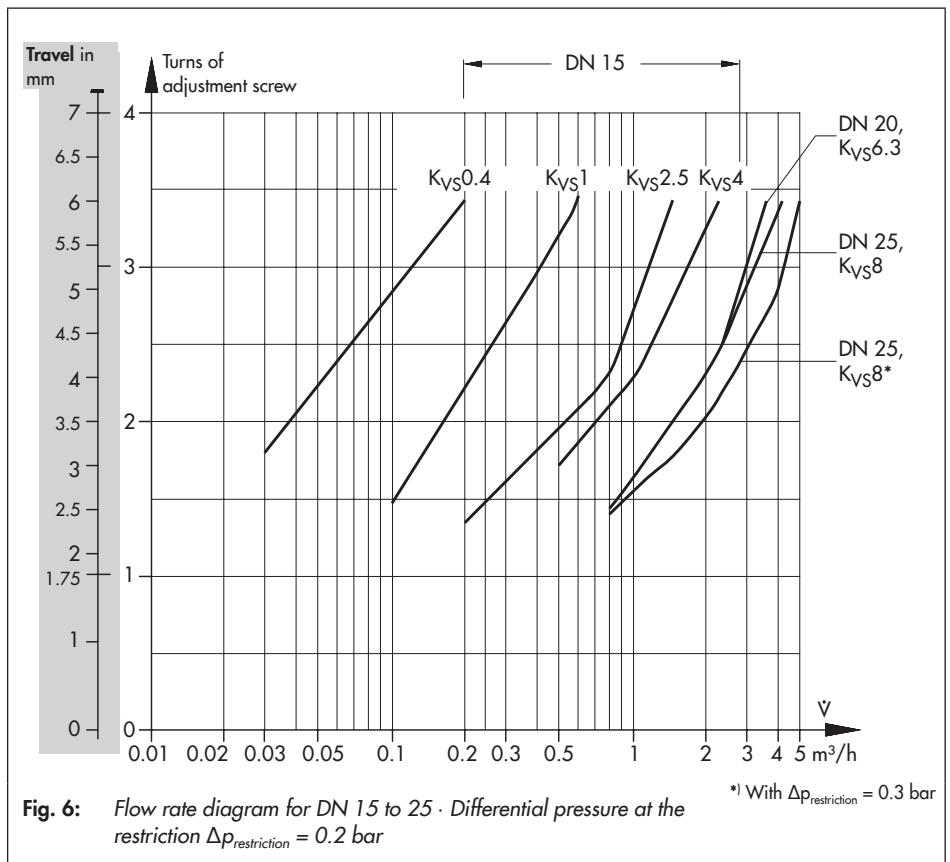

Start-up and operation

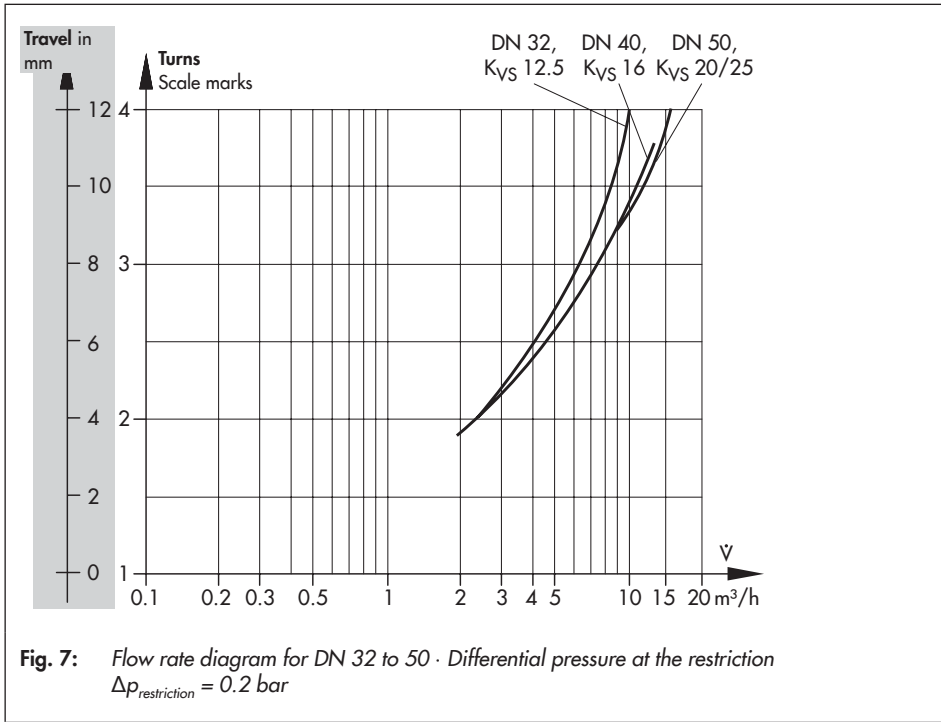

Fig. 7: Flow rate diagram for DN 32 to 50 · Differential pressure at the restriction $\Delta p_{restriction} = 0.2 \text{ bar}$

7 Servicing

The regulators do not require much maintenance. Nevertheless, they are subject to natural wear, particularly at the actuator, seat, plug, bellows seal and operating diaphragm. Depending on the operating conditions, check the regulator at regular intervals to avoid possible malfunctions. Plant operators are responsible for drawing up an inspection and test plan. Details on faults and how to remedy them can be found in Table 7.

SAMSON recommends removing the regulator from the pipeline before performing any maintenance or service work.



Tip

SAMSON's After-sales Service can support you in drawing up an inspection and test plan for your plant.

⚠ DANGER

Risk of bursting in pressure equipment.

Valves and pipelines are pressure equipment. Improper opening can lead to device components bursting.

- Before starting any work on the device, depressurize all plant sections affected as well as the valve.
- Drain the process medium from the plant sections affected as well as from the valve.
- If necessary, a suitable overpressure protection must be installed in the plant section.
- Wear personal protective equipment.

⚠ DANGER

Risk of fatal injury due to electric shock.

- ➔ Do not remove any covers to perform adjustment work on live parts.
- ➔ Before performing any work on the device and before opening the device, disconnect the supply voltage and protect it against unintentional reconnection.
- ➔ Only use power interruption devices that are protected against unintentional reconnection of the power supply.
- ➔ The electric actuators are protected against spray water (IP 54). Avoid jets of water.

⚠ WARNING

Risk of personal injury due to residual process medium in the valve.

While working on the valve, residual medium can flow out of the valve and, depending on its properties, cause personal injury, e.g. (chemical) burns.

- If possible, drain the process medium from the plant sections affected and from the valve.
- Wear protective clothing, safety gloves and eye protection.

⚠ WARNING

Risk of burn injuries due to hot or cold components and pipelines.

Depending on the process medium, valve components and pipelines may get very hot or cold and cause burn injuries.

- Allow components and pipelines to cool down or warm up to the ambient temperature.
 - Wear protective clothing and safety gloves.
-

ⓘ NOTICE

Risk of regulator damage due to incorrect servicing or repair.

Only allow trained staff to perform service and repair work.

ⓘ NOTICE

Risk of regulator damage due to over- or under-torquing.

Observe the specified torques when tightening regulator components. Excessive tightening torques lead to parts wearing out more quickly. Parts that are too loose may cause leakage.

Observe the tightening torques specified in Chapter 7.5.

i Note

The regulator was checked by SAMSON before delivery.

- The product warranty becomes void if service or repair work not described in these instructions is performed without prior agreement by SAMSON's After-sales Service.
 - Only use original spare parts by SAMSON, which comply with the original specifications.
-

7.1 Replacing the electric actuator

→ See Fig. 3

The electric actuator can be replaced while the process is running or after a plant shut-down.

The mounting procedure is described in the associated mounting and operating instructions of the electric actuator.

! DANGER

Risk of fatal injury due to electric shock.

- Do not remove any covers to perform adjustment work on live parts.
- Before performing any work on the device and before opening the device, disconnect the supply voltage and protect it against unintentional reconnection.
- Only use power interruption devices that are protected against unintentional reconnection of the power supply.
- The electric actuators are protected against spray water (IP 54). Avoid jets of water.

i Note

The actuator stem of electric actuators with fail-safe action must be retracted before mounting or removing the electric actuator. Refer to the mounting and operating instructions of the electric actuator with fail-safe action for more details. See information under 'Referenced documents' on page 8.

i Note

Refer to the mounting and operating instructions of the electric actuator for more details. See information under 'Referenced documents' on page 8.

Removing the electric actuator

The procedure described below refers to electric actuators without fail-safe action.

6. Disconnect the supply voltage from the electric actuator (see information under 'Referenced documents' on page 8).
7. Unscrew the coupling nut (10.2). Remove the electric actuator (10) from the connecting piece (8) of the valve.

Mounting the electric actuator

The procedure described below refers to electric actuators without fail-safe action.

1. Place the electric actuator (10) onto the connecting piece (8) of the valve and fasten with the coupling nut (10.2). Observe the tightening torques specified in Chapter 7.5.
2. Connect the supply voltage to the electric actuator (see information under 'Referenced documents' on page 8).

7.2 Replacing the restriction

⚠ DANGER

Risk of fatal injury due to electric shock.

- ➔ Do not remove any covers to perform adjustment work on live parts.
- ➔ Before performing any work on the device and before opening the device, disconnect the supply voltage and protect it against unintentional reconnection.
- ➔ Only use power interruption devices that are protected against unintentional reconnection of the power supply.
- ➔ The electric actuators are protected against spray water (IP 54). Avoid jets of water.

ⓘ NOTICE

Risk of regulator damage due to over- or under-torquing.

Observe the specified torques when tightening regulator components. Excessive tightening torques lead to parts wearing out more quickly. Parts that are too loose may cause leakage.

Observe the specified tightening torques.

ⓘ NOTICE

Risk of damage to the facing of the seat and plug due to incorrect service or repair.

Always replace both the seat and plug.

ⓘ NOTICE

DN 15 to 25: Unscrew the adjustment screw (8.3) before removing the connecting piece (8).

ⓘ Note

SAMSON's After-sales Service can support you concerning lubricant, tightening torques and tools approved by SAMSON.

ⓘ Note

The socket wrench for DN 15 to 25 can also be made, for example from a GEDORE screwdriver bit (IN 19-19) by drilling a 17-mm-deep hole ($\varnothing 17$) into a 17 mm hex bit.

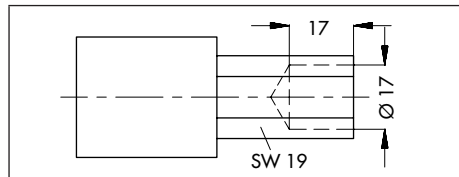

SAMSON order no. 1280-3001

ⓘ Note

The actuator stem of electric actuators with fail-safe action must be retracted before mounting or removing the electric actuator. Refer to the mounting and operating instructions of the electric actuator with fail-safe action for more details. See information under 'Referenced documents' on page 8.

Removing the restriction

The procedure described below refers to electric actuators without fail-safe action.

1. Put the regulator out of operation (see Chapter 9.1).
2. **DN 15 to 25:** undo the side adjustment screw (8.3) and unscrew the connecting piece (8) belonging to the restriction using a socket wrench.
DN 32 to 50: unscrew the connecting piece (8) belonging to the restriction.
3. Remove the seal (8.7).

i Note

The actuator stem of electric actuators with fail-safe action must be retracted before mounting or removing the electric actuator. Refer to the mounting and operating instructions of the electric actuator with fail-safe action for more details. See information under 'Referenced documents' on page 8.

Assembly of the restriction

The procedure described below refers to electric actuators without fail-safe action.

1. Insert the seal (8.7).
2. **DN 15 to 25:** screw the connecting piece (8) belonging to the restriction using a socket wrench. Screw in the side adjustment screw (8.3). Observe the tightening torques specified in Chapter 7.5.
DN 32 to 50: screw the connecting piece (8) belonging to the restriction. Observe the tightening torques specified in Chapter 7.5.
3. Install the regulator into the pipeline.
4. Fasten the electric actuator (10) using the coupling nut (10.2) to the connecting piece (8) of the valve. Observe the tightening torques specified in Chapter 7.5.
5. Connect the supply voltage to the electric actuator (see Chapter 6.1.1).
6. Put the regulator into operation (see Chapter 6).

7.3 Replacing the seat and plug

! NOTICE

Risk of regulator damage due to over- or under-torquing.

Observe the specified torques when tightening regulator components. Excessive tightening torques lead to parts wearing out more quickly. Parts that are too loose may cause leakage.

Observe the specified tightening torques.

! NOTICE

Risk of damage to the facing of the seat and plug due to incorrect service or repair.

Always replace both the seat and plug.

i Note

The socket wrench for DN 15 to 25 can also be made, for example from a GEDORE screwdriver bit (IN 19-19) by drilling a 17-mm-deep hole (Ø17) into a 17 mm hex bit.

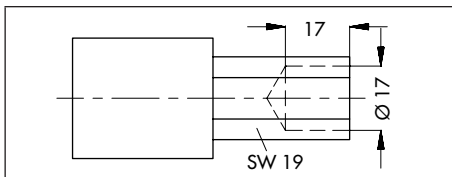

SAMSON order no. 1280-3001

i Note

SAMSON's After-sales Service can support you concerning lubricant, tightening torques and tools approved by SAMSON.

Disassembly

1. Put the regulator out of operation (see Chapter 9.1).
2. Unscrew the control line (7).
3. Unscrew the screws (6.2). Remove the diaphragm case (6.3) together with the operating diaphragm with diaphragm plate (6.1).
4. **DN 15 to 25:** unscrew the guide nipple (3.6) using a socket wrench and pull it out.
DN 32 to 50: unscrew the plug nipple (3.5) and pull out the guide nipple (3).
5. Remove the seal (3.6).
6. Thoroughly clean the seat (2), plug (3) and balancing mechanism (3.1). Replace damaged parts with new ones.
7. Check the control line (7) for any blockages.
8. Unscrew the seat (2) using a seat wrench if the seat facing is damaged.

Assembly

1. Screw in the seat (2) using a seat wrench. Observe the tightening torques specified in Chapter 7.5.
2. Renew the seal (3.6) and insert it into the body.
3. **DN 15 to 25:** insert the guide nipple (3) and screw it in using a socket wrench. Observe the tightening torques specified in Chapter 7.5.
DN 32 to 50: insert the the guide nipple (3.6) and screw in the plug nipple (3.5). Observe the tightening torques specified in Chapter 7.5.
4. Check the facings of the diaphragm case (6.3) and the valve body (1) for dirt and clean them, if necessary.
5. Place the operating diaphragm (6.1) and diaphragm case (6.3) onto the valve body (1).
6. Tighten the screws in a crisscross pattern. Observe the tightening torques specified in Chapter 7.5.
7. Screw on the control line (7). Observe the tightening torques specified in Chapter 7.5.
8. Install the regulator into the pipeline.
9. Fasten the electric actuator (10) using the coupling nut (10.2) to the connecting piece (8) of the valve. Observe the tightening torques specified in Chapter 7.5.
10. Connect the supply voltage to the electric actuator (see Chapter 6.1.1).
11. Put the regulator into operation (see Chapter 6).

7.4 Replacing the operating diaphragm

→ See Fig. 3

NOTICE

Risk of regulator damage due to over- or under-torquing.

Observe the specified torques when tightening regulator components. Excessive tightening torques lead to parts wearing out more quickly. Parts that are too loose may cause leakage.

Observe the specified tightening torques.

Note

SAMSON's After-sales Service can support you concerning lubricant, tightening torques and tools approved by SAMSON.

Note

The stem surface is roller-burnished. Do not reface the stem.

After replacing the diaphragm stem, the nipple (guide bushing) in the actuator case must be replaced as well.

Tip

The associated order number is written on the actual rolling diaphragm.

Servicing

Removal

1. Put the regulator out of operation (see Chapter 9.1).
2. Unscrew the control line (7).
3. Unscrew the screws (6.2). Remove the diaphragm case (6.3) together with the operating diaphragm with diaphragm plate (6.1).

Mounting

i Note

Before refastening the actuator, make sure that the operating diaphragm has been inserted properly into the ring groove.

1. Check the facings of the valve body (1) and the diaphragm case (6.3) for dirt and clean them, if necessary.
2. Place the operating diaphragm (6.1) and diaphragm case (6.3) onto the valve body (1).
3. Tighten the screws in a crisscross pattern. Observe the tightening torques specified in Chapter 7.5.
4. Screw on the control line (7). Observe the tightening torques specified in Chapter 7.5.
5. Install the regulator into the pipeline.
6. Fasten the electric actuator (10) using the coupling nut (10.2) to the connecting piece (8) of the valve. Observe the tightening torques specified in Chapter 7.5.
7. Connect the supply voltage to the electric actuator (see Chapter 6.1.1).

8. Put the regulator into operation (see Chapter 6).

7.5 Tightening torques

→ See Fig. 3

Table 6: Tightening torques of the regulator components

Part	Nominal size	Tightening torque in Nm
Coupling nut (1.4)	DN 15	80
	DN 20	95
	DN 25	110
	DN 32	130
	DN 40	160
Seat (2)	DN 15 to 25	45
	DN 32 to 50	110
Guide nipple with plug (3)	DN 15 to 25	70
Plug nipple (3.5)	DN 32 to 50	110
Screws (6.2)	DN 15 to 32	8
	DN 40 to 50	18
Control line connection (7)	DN 15 to 50	22
Connecting piece (8)	DN 15 to 25	80
	DN 32 to 50	110
Coupling nut (10.2) (actuator)	DN 15 to 50	20

7.6 Lubricants and sealants

i Note

SAMSON's After-sales Service can support you concerning lubricants and sealants approved by SAMSON.

7.7 Preparation for return shipment

Defective devices can be returned to SAMSON for repair. Proceed as follows to return devices to SAMSON:

1. Put the regulator out of operation (see Chapter 9.1).
2. If necessary, decontaminate the regulator. Remove any residual process medium.
3. Fill in the Declaration on Contamination. The declaration form can be downloaded from our website at
▶ www.samsongroup.com > SERVICE > After Sales Service.
4. Send the device together with the filled-in form to your nearest SAMSON subsidiary. SAMSON subsidiaries are listed on our website at
▶ www.samsongroup.com > About SAMSON > Sales offices.

7.8 Ordering spare parts and operating supplies

Contact your nearest SAMSON subsidiary or SAMSON's After-sales Service for information on spare parts, lubricants and tools.

8 Malfunctions

The malfunctions listed in Table 7 are caused by mechanical faults and incorrect regulator sizing. In the simplest case, the functioning can be restored following the recommended action. Special tools may be required for repair work.

Exceptional operating and installation conditions may lead to changed situations that may affect the control response and lead to malfunctions. For troubleshooting, the conditions, such as installation, process medium, temperature and pressure conditions, must be taken into account.

SAMSON's After-sales Service can help during troubleshooting. Further information is available in Chapter 11.1.

DANGER

Risk of bursting in pressure equipment.

Valves and pipelines are pressure equipment. Improper opening can lead to device components bursting.

- Before starting any work on the device, depressurize all plant sections affected as well as the valve.
 - Drain the process medium from the plant sections affected as well as from the valve.
 - If necessary, a suitable overpressure protection must be installed in the plant section.
 - Wear personal protective equipment.
-

DANGER

Risk of fatal injury due to electric shock.

- Do not remove any covers to perform adjustment work on live parts.
 - Before performing any work on the device and before opening the device, disconnect the supply voltage and protect it against unintentional reconnection.
 - Only use power interruption devices that are protected against unintentional reconnection of the power supply.
 - The electric actuators are protected against spray water (IP 54). Avoid jets of water.
-

Note

Contact SAMSON's After-sales Service for malfunctions not listed in the table and when the malfunction cannot be remedied as described.

Tip

SAMSON's After-sales Service can support you in drawing up an inspection and test plan for your plant.

Table 7: Troubleshooting

Malfunction	Possible reasons	Recommended action
Flow rate exceeds adjusted set point	Insufficient pressure pulses on the operating diaphragm.	→ Clean the control line, needle valve and screw fittings.
	Foreign particles blocking the plug	→ Remove foreign particles. → Replace damaged parts. → Contact SAMSON's After-sales Service.
	Seat and plug are worn or leak.	→ Replace the damaged seat and plug. → Contact SAMSON's After-sales Service.
	Regulator or K_{VS} coefficient too large	→ Check the sizing. → Change K_{VS} coefficient, if necessary or install a different sized regulator. → Contact SAMSON's After-sales Service.
	Defective operating diaphragm	→ Replace damaged operating diaphragm.
Flow set point not reached.	Safety device, e.g. pressure limiter, has been triggered.	→ Check plant. → Unlock safety device.
	Stem of electric actuator is extended.	→ Check control signal issued by the electric control device.
	Plant differential pressure too low.	→ Compare differential pressure in the plant with the plant's drag. → Contact SAMSON's After-sales Service.
	Regulator or K_{VS} coefficient too small	→ Check the sizing. → Change K_{VS} coefficient, if necessary or install a different sized regulator. → Contact SAMSON's After-sales Service.
	Foreign particles blocking the plug	→ Remove foreign particles. → Replace damaged parts. → Contact SAMSON's After-sales Service.
	Control line blocked	→ Clean the control line and screw fittings.
	Strainer blocked.	→ Clean the strainer.
	Regulator installed against the flow.	→ Install the regulator so that the direction of flow matches the direction indicated by the arrow on the body.
Control loop hunts.	Regulator or K_{VS} coefficient too large	→ Check the sizing. → Change K_{VS} coefficient, if necessary or install a different sized regulator. → Contact SAMSON's After-sales Service.

9 Decommissioning and removal

⚠ DANGER

Risk of bursting in pressure equipment.

Regulators and pipelines are pressure equipment. Improper opening can lead to bursting of the regulator.

- Before starting any work on the regulator, depressurize all plant sections affected as well as the regulator.
 - Drain the process medium from the plant sections affected as well as from the regulator.
 - Wear personal protective equipment.
-

⚠ DANGER

Risk of fatal injury due to electric shock.

- Before performing any work on the device and before opening the device, disconnect the supply voltage and protect it against unintentional reconnection.
 - Only use power interruption devices that are protected against unintentional reconnection of the power supply.
-

⚠ WARNING

Risk of burn injuries due to hot or cold components and pipeline.

Regulator components and the pipeline may become very hot or cold. Risk of burn injuries.

- Allow components and pipelines to cool down or warm up to the ambient temperature.
 - Wear protective clothing and safety gloves.
-

⚠ WARNING

Risk of personal injury due to residual process medium in the regulator.

While working on the regulator, residual process medium can escape and, depending on its properties, may lead to personal injury, e.g. (chemical) burns.

Wear protective clothing, safety gloves and eye protection.

9.1 Decommissioning

⚠ WARNING

Observe the relevant safety regulations on mounting or removing the electric actuator.

To decommission the regulator for service and repair work or disassembly, proceed as follows:

1. Close the shut-off valve on the upstream side of the valve.
2. Close the shut-off valve on the downstream side of the valve.
3. Completely drain the pipelines and valve.
4. Depressurize the plant. Shut off or disconnect the control line.
5. If necessary, allow the pipeline and regulator to cool down or warm up to the ambient temperature.
6. Remove the electric actuator from the valve (see Chapter 7.1).
7. Remove the valve from the pipeline.

10 Disposal



SAMSON is a producer registered at the following European institution ▶ <https://www.samsongroup.com/en/about-samson/environment-social-governance/material-compliance/waste-electrical-and-electronic-equipment-weee-and-its-safe-disposal/>.
WEEE reg. no.: DE 62194439

Information on substances listed as substances of very high concern (SVHC) on the candidate list of the REACH regulation can be found in the document "Additional Information on Your Inquiry/Order", which is added to the order documents, if applicable. This document includes the assigned SCIP number, which can be entered into the database on the European Chemicals Agency (ECHA) website (▶ <https://www.echa.europa.eu/scip-database>) to find out more information on the SVHC.

i Note

SAMSON can provide you with a recycling passport on request. Simply e-mail us at aftersaleservice@samsongroup.com giving details of your company address.

💡 Tip

On request, SAMSON can appoint a service provider to dismantle and recycle the product as part of a distributor take-back scheme.

- Observe local, national and international refuse regulations.
- Do not dispose of components together with your other household waste.

11 Appendix

11.1 After-sales service

Contact SAMSON's After-sales Service for support concerning service or repair work or when malfunctions or defects arise.

E-mail address

You can reach our after-sales service at aftersalesservice@samsongroup.com.

Addresses of SAMSON AG and its subsidiaries

The addresses of SAMSON, its subsidiaries, representatives and service facilities worldwide can be found on our website (▶ www.samsongroup.com) or in all SAMSON product catalogs.

To assist diagnosis and in case of an unclear mounting situation, specify the following details (so far as possible). See Chapter 2:

- Type designation (valve, actuator) and nominal size
- Model number and configuration ID
- Upstream and downstream pressure
- Medium temperature and process medium
- Min. and max. flow rate
- Is a strainer installed?

- Installation drawing showing the exact location of the regulator and all the additionally installed components (shut-off valves, pressure gauge etc.)

11.2 Certificates

The EU declarations of conformity are included on the next pages:

- EU declaration of conformity in compliance with Pressure Equipment Directive 2014/68/EU on page 51.
- EU declaration of conformity in compliance with Machinery Directive 2006/42/EC for Type 2488 Ventil on page 55.
- Declaration of incorporation in compliance with Machinery Directive 2006/42/EC for the Type 2488 Valve with other actuators on page 55.

EU DECLARATION OF CONFORMITY TRANSLATION



Module D / N° CE-0062-PED-D-SAM 001-22-DEU

For the following products, SAMSON hereby declares under its sole responsibility:

Devices	Series	Type	Version
Control valve for hot water and steam with fail-safe action in heating systems	Actuator 3374-21/-26 (Force 2000 N)		with Type 3241, 2811, 2814, 2823, 3321 EU-Type examination (production type), Module B, Certificate no.: 01 202 931/B-15-0030-01, type-tested according to standard DIN EN 14597:2015
Control valve for water and water-steam with fail-safe action in heating systems	Actuator 5725-310/-313/-320/-323 5725-410/-420 5825-10/-13/-20/-23 (Force 500 N) (Product number 2770)		with Type 3214 (2814), 2423 (2823), 3213 (2710), 3222 (2710), 2458 (2730), 2493 (2730) EU-Type examination (production type), Module B, Certificate no.: 01 202 641/B-19-0017-01 type-tested according to standard DIN EN 14597:2015, appendix DX

that the products mentioned above comply with the requirements of the following standards:

Directive of the European Parliament and of the Council on the harmonization of the laws of the Member States relating to the making available on the market of pressure equipment	2014/68/EU	of 15 May 2014
Applied conformity assessment procedure for fluids according to Article 4(1)	Module D	Certificate-No.: N°CE-0062-PED-D-SAM 001-22-DEU by Bureau Veritas 0062

The manufacturer's quality management system is monitored by the following notified body:
Bureau Veritas Services SAS, 8 Cours du Triangle, 92800 PUTEAUX – LA DEFENSE

Applied harmonised standards and technical specifications: EN 12516-2, EN 12516-3, EN 12266-1, ASME B16.34

Manufacturer: SAMSON AKTIENGESELLSCHAFT, Weismüllerstraße 3, 60314 Frankfurt am Main, Germany

Frankfurt am Main, 15th November 2022

Dr. Andreas Wild
Chief Executive Officer (CEO)

Dr. Thomas Steckenreiter
Chief Technology Officer (CTO)

Revision 09

Classification: Public · SAMSON AKTIENGESELLSCHAFT · Weismüllerstraße 3 · 60314 Frankfurt am Main, Germany

Page 1 of 1

EU DECLARATION OF CONFORMITY
TRANSLATION



Module A

For the following products, SAMSON hereby declares under its sole responsibility:

Devices	Series	Type	Version			
Self-operated Regulators	43	2432	DIN EN, body, CC499K and EN-GJS-400-18-LT, DN 50, PN 25, fluids G2, L2, L1 ¹⁾			
	43	2436	DIN EN, body, CC499K and EN-GJS-400-18-LT, DN 50, PN 25, fluids G2, L2, L1 ¹⁾			
	43	2437	DIN EN, body, CC499K and EN-GJS-400-18-LT, DN 50, PN 25, fluids G2, L2, L1 ¹⁾			
Self-operated Regulators	---	2111	DIN EN, body, EN-GJS-400-18-LT, DN 50, PN 25, fluids G2, L2, L1 ¹⁾ DIN EN, body, 1.0619 and 1.4408, DN 40-50, PN 40, fluids G2, L2, L1 ¹⁾ ANSI, body, A216 WCC and A351 CF8M, NPS 1½-2, Class 300, fluids G2, L2, L1 ¹⁾			
	Three-way valve	---	2119	DIN EN, body, EN-GJL-250 and 1.0619, DN 65-125, PN 16, fluids G2, L2, L1 ¹⁾ DIN EN, body, 1.0619, DN 50-80, PN 25, fluids G2, L2, L1 ¹⁾ DIN EN, body, 1.0619 and 1.4408, DN 40-50, PN 40, fluids G2, L2, L1 ¹⁾ ANSI, body, A216 WCC and A351 CF8M, NPS 2½-4, Class 150, fluids G2, L2, L1 ¹⁾ ANSI, body, A216 WCC and A351 CF8M, NPS 1½, Class 300, fluids G2, L2, L1 ¹⁾		
				Control valve	---	3222
Three-way valve						
Three-way valve	---	3260	DIN EN, body, EN-GJL-250, DN 65-200, PN 16, fluids G2, L2 ²⁾			
Globe valve Three-way valve	V2001	3531	DIN EN, body, EN-GJS-400-18-LT, DN 50-80, PN 25, fluids G2, L2, L1 ¹⁾			
		3535	DIN EN, body, 1.0619 and 1.4408, DN 32-40, PN 25, all fluids ANSI, body, A216 WCC and A351 CF8M, NPS 1½-2, Class 150, all fluids			
Control valve	---	3214	DIN EN, body, EN-GJL-250, DN 65-125, PN 16, fluids G2, L2, L1 ¹⁾ DIN EN, body, EN-GJS-400-18-LT, DN 50-80, PN 25, fluids G2, L2, L1 ¹⁾ ANSI, body, A126 B, NPS 3-4, Class 125, fluids G2, L2, L1 ¹⁾ ANSI, body, A216 WCC and A351 CF8M, NPS 1½-2, Class 150, all fluids			
			Self-operated Regulators	42	2423	DIN EN, body, EN-GJL-250 and EN-GJS-400-18-LT, DN 65-125, PN 16, fluids G2, L2, L1 ¹⁾ DIN EN, body, EN-GJS-418-LT, DN 50-80, PN 25, fluids G2, L2, L1 ¹⁾ DIN EN, body, 1.0619 and 1.4408, DN 32-50, PN 16, all fluids DIN EN, body, 1.0619 and 1.4408, DN 32-40, PN 25, all fluids ANSI, body, A126 B, NPS 3-4, Class 125, fluids G2, L2, L1 ¹⁾ ANSI, body, A216 WCC and A351 CF8M, NPS 1½-2, Class 150, all fluids
Self-operated Regulators	42	2422				DIN EN, body, EN-GJL-250 and EN-GJS-400-18-LT, DN 65-125, PN 16, fluids G2, L2, L1 ¹⁾ DIN EN, body, EN-GJS-400-18-LT, DN 50-80, PN 25, fluids G2, L2, L1 ¹⁾ DIN EN, body, 1.0619, 1.4408 and 1.6220+QT, DN 32-50, PN 16, all fluids ANSI, body, A126 B, NPS 3-4, Class 125, fluids G2, L2, L1 ¹⁾ ANSI, body, A216 WCC, A351 CF8M and A352 LCC, NPS 1½-2, Class 150, all fluids
			Strainers	1N/1NI	2601	DIN EN, body, CB752S, G 2 (DN50), PN25, fluids G2, L2 ³⁾
Strainers	2N/2NI	2602	DIN EN, body, EN-GJL-250, DN 200-250, PN 10, fluids G2, L2, L1 ¹⁾ DIN EN, body, EN-GJL-250, DN 65-125, PN 16, fluids G2, L2, L1 ¹⁾ DIN EN, body, EN-GJS-400-18-LT, DN 100-125, PN 16, fluids G2, L2, L1 ¹⁾ DIN EN, body, EN-GJS-400-18-LT, DN 50-80, PN 25, fluids G2, L2, L1 ¹⁾ DIN EN, body, 1.4408, DN 32-50, PN 16, all fluids			
			Self-operated Regulators	44	2373/2375	ANSI, body, A995 4A and A995 5A, NPS 1½-2, Class 150, all fluids
					2440 (44-0B) 2441 (44-1B) 2446 (44-6B)	DIN EN, body, EN-GJS-400-18-LT, DN 50, PN 25, fluids G2, L2, L1 ¹⁾
			Self-operated Regulators	44	2442 (44-2) 2443 (44-3) 2444 (44-4) 2447 (44-7) 2448 (44-8) 2449 (44-9)	DIN EN, body, EN-GJS-400-18-LT and CC499K, DN 50, PN 25, fluids G2, L2, L1 ¹⁾

Revision 00

EU DECLARATION OF CONFORMITY TRANSLATION



Devices	Series	Type	Version	
Self-operated Regulators	45	2451 (45-1)	DIN EN, body, EN-GJS-400-18-LT and CC499K, DN 50, PN 25, fluids G2, L2, L1 ¹⁾	
		2452 (45-2)		
		2453 (45-3)		
		2454 (45-4)		
		2456 (45-6)		
	46	2465 (46-5)	DIN EN, body, EN-GJS-400-18-LT and CC499K, DN 50, PN 25, fluids G2, L2, L1 ¹⁾	
		2486 (46-6)		
		2487 (46-7)		
		2469 (46-9)		
	47	2471 (47-1)	DIN EN, body, EN-GJS-400-18-LT and CC499K, DN 50, PN 25, fluids G2, L2, L1 ¹⁾	
		2474 (47-4)		
		2475 (47-5)		
		2479 (47-9)		
	40	2405	2488	DIN EN, body, EN-GJS-400-18-LT and CC499K, DN 50, PN 25, fluids G2, L2, L1 ¹⁾
			2489	
		2406	DIN EN, body, EN-GJS-400-18-LT, DN 50, PN 25, fluids G2, L2, L1 ¹⁾	
			ANSI, body, A216 WCC and A351 CF8M, NPS 1½-2, Class 150, all fluids	
			DIN EN, body, EN-GJL-250, DN 65-125, PN 16, fluids G2, L2, L1 ¹⁾	
			DIN EN, body, EN-GJS-400-18-LT, DN 50, PN 25, fluids G2, L2, L1 ¹⁾	
			ANSI, body, A126 B, NPS 3-4, Class 125, fluids G2, L2, L1 ¹⁾	
			ANSI, body, A216 WCC and A351 CF8M, NPS 1½-2, Class 150, all fluids	
		41	2412	DIN EN, body, EN-GJL-250, DN 65-100, PN 16, fluids G2, L2, L1 ¹⁾
			2417	DIN EN, body, EN-GJS-400-18-LT, DN 50-80, PN 25, fluids G2, L2, L1 ¹⁾
	42	2421 RS	ANSI, body, A126 B, NPS 3-4, Class 150, all fluids	
			ANSI, body, A216 WCC and A351 CF8M, NPS 1½-2, Class 150, all fluids	
	---	2331 2337	DIN EN, body, 1.0619, 1.4408, 1.4571 and 1.4401/1.4404, DN 32-50, PN 16, all fluids	
			DIN EN, body, 1.0619, 1.4408, 1.4571 and 1.4401/1.4404, DN 32-40, PN 25, all fluids	
ANSI, body, A216 WCC, A351 CF8M and A182 F316/A182 F316L, NPS 1½-2, Class 150, all fluids				
DIN EN, body, EN-GJL-250, DN 65-200, PN 16, fluids G2, L2 ²⁾				
DIN EN, body, EN-GJS-400-18-LT, DN 65-150, PN 16, fluids G2, L2 ²⁾				
---	2333 2335	DIN EN, body, EN-GJS-400-18-LT, DN 65-125, PN 25, fluids G2, L2, L1 ¹⁾		
		ANSI, body, A126 B, NPS 3-4, Class 125, fluids G2, L2, L1 ¹⁾		
---	2334	DIN EN, body, EN-GJL-250, DN 65-125, PN 16, fluids G2, L2, L1 ¹⁾		
		DIN EN, body, EN-GJS-400-18-LT, DN 65-125, PN 16, fluids G2, L2, L1 ¹⁾		
		DIN EN, body, EN-GJS-400-18-LT, DN 65-80, PN 25, fluids G2, L2, L1 ¹⁾		
---	2404-1	ANSI, body, A126 B, NPS 3-4, Class 125, fluids G2, L2, L1 ¹⁾		
		ANSI, body, A216 WCC und A351 CF8M, NPS 1½-2, Class 150, all fluids		
---	2404-2	DIN EN, body, EN-GJL-250, DN 65-125, PN16, fluids G2, L2, L1 ¹⁾		
		ANSI, body, A126 B, NPS 3-4, Class 125, fluids G2, L2, L1 ¹⁾		

¹⁾ Gases according to Article 4(1)(c.i), second indent
Liquids according to Article 4(1)(c.ii)

²⁾ Gases according to Article 4(1)(c.i), second indent
Liquids according to Article 4(1)(c.ii), second indent

Revision 00

Classification: Public · SAMSON AKTIENGESELLSCHAFT · Weismuellerstrasse 3 · 60314 Frankfurt am Main, Germany

Page 2 of 3

EU DECLARATION OF CONFORMITY
TRANSLATION



That the products mentioned above comply with the requirements of the following standards:

Directive of the European Parliament and of the Council on the harmonization of the laws of the Member States relating to the making available on the market of pressure equipment	2014/68/EU	of 15. May 2014
Applied conformity assessment procedure for fluids according to Article 4(1)	Module A	

Technical standards applied: DIN EN 12516-2, DIN EN 12516-3, ASME B16.34

Manufacturer: SAMSON AG, Weismüllerstraße 3, 60314 Frankfurt am Main, Germany

Frankfurt am Main, 26. August 2022

ppa. Norbert Tollas
Senior Vice President
Global Operations

i.V. Peter Scheermesser
Director
Product Maintenance & Engineered Products

Revision 00

DECLARATION OF INCORPORATION TRANSLATION



Declaration of Incorporation in Compliance with Machinery Directive 2006/42/EC

For the following product:
Type 2488 Valve

We certify that the Type 2488 Valve is partly completed machinery as defined in the Machinery Directive 2006/42/EC and that the safety requirements stipulated in Annex I, 1.1.2, 1.1.3, 1.1.5, 1.3.2, 1.3.4 and 1.3.7 are observed. The relevant technical documentation described in Annex VII, part B has been compiled.

Products we supply must not be put into service until the final machinery into which it is to be incorporated has been declared in conformity with the provisions of the Machinery Directive 2006/42/EC.

Operators are obliged to install the products observing the accepted industry codes and practices (good engineering practice) as well as the mounting and operating instructions. Operators must take appropriate precautions to prevent hazards that could be caused by the process medium and operating pressure in the valve as well as by the signal pressure and moving parts.

The permissible limits of application and mounting instructions for the products are specified in the associated mounting and operating instructions; the documents are available in electronic form on the Internet at www.samsongroup.com.

For product descriptions refer to:

- Type 2488/5xxx-x and Type 2488/TROVIS 5xxx-x Pressure-independent Control Valves: Mounting and Operating Instructions EB 3135-1

Referenced technical standards and/or specifications:

- VCI, VDMA, VGB: "Leitfaden Maschinenrichtlinie (2006/42/EG) – Bedeutung für Armaturen, Mai 2018" [German only]
- VCI, VDMA, VGB: "Zusatzdokument zum Leitfaden Maschinenrichtlinie (2006/42/EG) – Bedeutung für Armaturen vom Mai 2018" [German only], based on DIN EN ISO 12100:2011-03

Comments:

- See mounting and operating instructions for residual hazards.
- Also observe the referenced documents listed in the mounting and operating instructions.

Persons authorized to compile the technical file:

SAMSON AG, Weismüllerstraße 3, 60314 Frankfurt am Main, Germany
Frankfurt am Main, 10 November 2021



Stephan Giesen
Director
Product Management

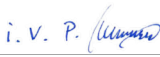

Peter Scheermesser
Director
Product Life Cycle Management and ETO
Development for Valves and Actuators

Revision no. 00

Classification: Public · SAMSON AKTIENGESELLSCHAFT · Weismüllerstraße 3 · 60314 Frankfurt, Germany

Page 1 of 1



SAMSON AKTIENGESELLSCHAFT
Weismüllerstraße 3 · 60314 Frankfurt am Main, Germany
Phone: +49 69 4009-0 · Fax: +49 69 4009-1507
samson@samsongroup.com · www.samsongroup.com