

Series 3730

Type 3730-3 Electropneumatic Positioner

with HART® communication

SAMSON



HART
COMMUNICATION PROTOCOL

Mounting and Operating Instructions

EB 8384-3 EN (1300-1612)

Firmware version 1.5x

Edition April 2016

CE Ex
certified

EB + CD

Definition of signal words



DANGER!

Hazardous situations which, if not avoided, will result in death or serious injury



WARNING!

Hazardous situations which, if not avoided, could result in death or serious injury



NOTICE

Property damage message or malfunction



Note:

Additional information



Tip:

Recommended action

1	Important safety instructions	8
2	Article code	9
3	Design and principle of operation	10
3.1	Additional equipment.....	11
3.2	Communication	12
3.2.1	Configuration using the TROVIS-VIEW software	13
3.3	Technical data	14
4	Attachment to the control valve – Mounting parts and accessories	20
4.1	Direct attachment.....	22
4.1.1	Type 3277-5 Actuator	22
4.1.2	Type 3277 Actuator	24
4.2	Attachment according to IEC 60534-6.....	26
4.3	Attachment according to VDI/VDE 3847	28
4.4	Attachment to Type 3510 Micro-flow Valve	34
4.5	Attachment to rotary actuators	34
4.5.1	Heavy-duty version	36
4.6	Reversing amplifier for double-acting actuators	38
4.6.1	Reversing amplifier (1079-1118 or 1079-1119).....	40
4.7	Attachment of external position sensor.....	42
4.7.1	Mounting the position sensor with direct attachment.....	43
4.7.2	Mounting the position sensor with attachment according to IEC 60534-6	45
4.7.3	Mounting the position sensor to Type 3510 Micro-flow Valve.....	46
4.7.4	Mounting on rotary actuators.....	47
4.8	Mounting the leakage sensor	48
4.9	Attaching positioners with stainless steel housings.....	49
4.10	Air purging function for single-acting actuators	49
4.11	Required mounting parts and accessories.....	50
5	Connections	55
5.1	Pneumatic connections.....	55
5.1.1	Signal pressure gauges	55
5.1.2	Supply pressure	55
5.1.3	Signal pressure (output).....	56
5.2	Electrical connections	56

5.2.1	Switching amplifier	59
5.2.1	Establishing communication	59
6	Operating controls and readings.....	61
6.1	Serial interface	63
6.2	HART® communication	63
6.2.1	Dynamic HART® variables	64
7	Start-up and settings	66
7.1	Defining the fail-safe position	66
7.2	Adjusting the volume restriction Q	67
7.3	Adapting the display direction	67
7.4	Limiting the signal pressure	68
7.5	Checking the operating range of the positioner	68
7.6	Initialization	69
7.6.1	MAX – Initialization based on maximum range	71
7.6.2	NOM – Initialization based on nominal range	72
7.6.3	MAN – Initialization based on a manually selected range	73
7.6.4	SUB – Substitute calibration	74
7.7	Zero calibration	77
7.8	Reset to default settings.....	78
8	Operation	79
8.1	Enabling and selecting parameters	79
8.2	Operating modes.....	79
8.2.1	Automatic and manual modes	79
8.2.2	Fail-safe position (SAFE)	80
8.3	Fault/malfunction.....	81
8.3.1	Confirming error messages.....	82
9	Adjusting the limit switch	83
9.1	Retrofitting an inductive limit switch	84
10	Maintenance	86
11	Servicing explosion-protected devices	86
12	Firmware update (serial interface).....	86
13	Maintenance, calibration and work on equipment	87

14	Code list	88
15	Dimensions in mm	106
15.1	Fixing levels according to VDI/VDE 3845 (September 2010)	109
16	Valve characteristic selection	110
	Index	129

**Note:**

The functions of the **EXPERTplus** Valve Diagnostics are described in the Operating Instructions ► **EB 8389**.

EB 8389 EN is included on the enclosed CD-ROM and is available on our website.

Firmware revisions	
Old	New
1.01	1.10
	The HART protocol as per HART® specification revision 5 is supported by default. The setting can be changed to HART® revision 6 in the TROVIS-VIEW software. HART® tools as well as AMS or handheld communicators are currently not supported by the revision 6 version.
	The following status messages have been added: <ul style="list-style-type: none"> • Code 76 – No emergency mode • Code 77 – Program load error Reading indicates the number of zero calibrations performed since the last initialization.
	For initialization of "AIR TO CLOSE" actuators, the direction of action (Code 7) is automatically set to increasing/decreasing.
	Code 3, the activation period of the enabled configuration function has been extended to 120 s.
1.10	1.20
	Electronics changed, no new functions added.
1.20	1.30
	New EXPERTplus diagnostics functions (Code 48) added. Positioner in EXPERTplus version with extended diagnostics features.
	An initialization procedure in progress can be canceled by pressing the rotary pushbutton.
	The position transmitter (Code 37) and solenoid valve (Code 45) options are automatically detected.
1.30	1.40
	All EXPERTplus functions can be used over HART® communication in this firmware version and higher.
	The fault alarm contact is triggered by the condensed state of the positioner. It is always active with "Maintenance alarm" condensed state. <ul style="list-style-type: none"> • When Code 32 = YES: also active with "Function check" condensed state • When Code 33 = YES: also active with "Maintenance required/Maintenance demanded" condensed state
	The Function check condensed state is additionally set for Test A1, A2, fault alarm output and position transmitter.
	The min./max. values of the temperature monitoring can be reset.

Firmware revisions	
Old	New
1.40	1.41
	Internal revisions
1.41	1.42
	Internal revisions
1.42	1.51
	All EXPERTplus diagnostic functions are available without having to activate them in the positioner (► EB 8389 on EXPERTplus Valve Diagnostics).
	Optional binary input with following actions: <ul style="list-style-type: none"> • Transmit switching state • Activate local write protection • Switch between automatic and manual modes • Various diagnostic functions ► EB 8389 (EXPERTplus valve diagnostics)
	The pressure limit (Code 16) is no longer automatically set during initialization.
1.51	1.54
	Internal revisions
1.54	1.55
	Analog input x option to connect commercially available position sensors with a 4 to 20 mA signal
	Code 4: the setting for 300 mm has been added to the pin position
1.55	1.56
	Internal revisions

1 Important safety instructions

For your own safety, follow these instructions concerning the mounting, start-up and operation of the device:

- The device is to be mounted, started up or operated only by trained and experienced personnel familiar with the product. According to these mounting and operating instructions, trained personnel is referred to as individuals who are able to judge the work they are assigned to and recognize possible dangers due to their specialized training, their knowledge and experience as well as their knowledge of the applicable standards.
- Explosion-protected versions of this device are to be operated only by personnel who has undergone special training or instructions or who is authorized to work on explosion-protected devices in hazardous areas. Refer to section 11.
- Any hazards that could be caused in the valve by the process medium, the signal pressure or by moving parts are to be prevented by taking appropriate precautions.
- If inadmissible motions or forces are produced in the pneumatic actuator as a result of the supply pressure level, it must be restricted using a suitable supply pressure reducing station.

To avoid damage to any equipment, the following also applies:

- Do not operate the positioner with the back of the positioner/vent opening facing upwards. The vent opening must not be sealed or restricted when the positioner is installed on site.

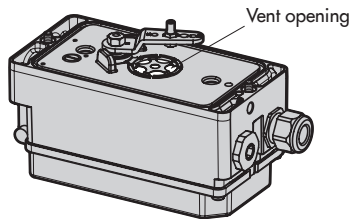

- Proper shipping and storage are assumed.
- Do not ground electric welding equipment near to the positioner.



Note: The device with a CE marking fulfills the requirements of the Directive 2014/34/EU and the Directive 2014/30/EU.
The declaration of conformity is included on the enclosed CD-ROM.

3 Design and principle of operation

The electropneumatic positioner is mounted on pneumatic control valves and is used to assign the valve position (controlled variable x) to the control signal (set point w). The electric signal from a controlling system is compared to the travel or the rotational angle of the control valve and a signal pressure (output variable y) is produced for the actuator.

The positioner consists of a travel sensor system (2) proportional to resistance, an analog

i/p converter with a downstream air capacity booster (7) and the electronics with microcontroller (5).

The positioner is fitted with three binary contacts as standard: A fault alarm output indicates a fault to the control room and two configurable software limit switches are used to indicate the end positions of the valve.

The valve position is transmitted as either an angle of rotation or travel to the pick-up lever and to the travel sensor (2) and supplied to an analog PD controller. An A/D converter (4) transmits the position of the valve to the microcontroller (5). The PD controller com-

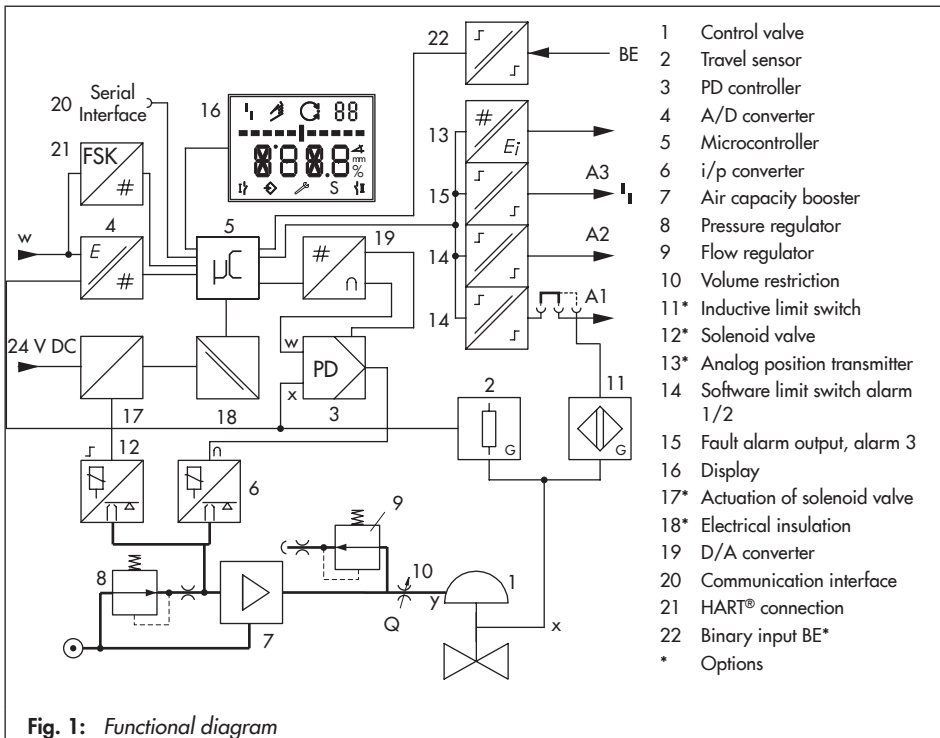

Fig. 1: Functional diagram

compares this actual position to the 4 to 20 mA DC control signal after it has been converted by the A/D converter (4). In case of a set point deviation, the activation of the i/p converter (6) is changed so that the actuator (1) is pressurized or vented accordingly over the downstream booster (7). As a result, the closure member of the valve (e.g. plug) is moved to the position determined by the set point.

The supply air is supplied to the booster (7) and the pressure regulator (8). An intermediate flow regulator (9) with fixed settings is used to purge the positioner and, at the same time, guarantees trouble-free operation of the booster. The output signal pressure supplied by the booster can be limited by software.

The volume restriction Q (10) is used to optimize the positioner.

The extended EXPERTplus diagnostics are integrated into the positioner. They provide information on the positioner and generate diagnostic and status messages, which allow faults to be pinpointed quickly.

The positioner is suitable for the following types of attachment using the corresponding accessories:

- Direct attachment to SAMSON Type 3277 Actuators
- Attachment to actuators according to IEC 60534-6 (NAMUR)
- Attachment according to VDI/VDE 3847
- Attachment to Type 3510 Micro-flow Valve
- Attachment to rotary actuators according to VDI/VDE 3845

3.1 Additional equipment

Solenoid valve

If the operating voltage for the solenoid valve (12) fails, the signal pressure for the booster is vented to the atmosphere. As a result, the actuator is vented and the valve moves to its fail-safe position.



NOTICE

The manual set point is automatically reset to 0 % after the solenoid valve is activated.

A different manual set point must be entered again (Code 1).

Position transmitter

The position transmitter (13) is a two-wire transmitter and issues the travel sensor signal as a 4 to 20 mA signal processed by the microcontroller.

Since this signal is issued independent of the positioner's input signal (minimum current 3.8 mA), the momentary travel/angle of rotation is controlled in real-time. Additionally, the position transmitter allows positioner faults to be indicated over a signal current of <2.4 mA or >21.6 mA.

Inductive limit switch

In this version, the rotary shaft of the positioner carries an adjustable tag which actuates the built-in proximity switch. The optional inductive contact (11) is connected to A1, while the remaining software limit switch is connected to A2.

External position sensor

In this version, only the sensor is mounted to the control valve. The positioner is located separately from the valve. The connection of x and y signals to the valve is established by cable and piping for air (only without inductive limit switch).

Analog input x

The **analog input x** option allows commercially available external linear or angle position sensors that use a 4 to 20 mA signal to be connected to the positioner. The analog input x is protected against reverse polarity and overload up to 24 V AC/DC. The positioner switches to open-loop operation (no closed-loop operation) as soon as the input signal falls below 2.5 mA.

Leakage sensor



By upgrading the positioner with a leakage sensor, it is possible to detect seat leakage when the valve is in the closed position.

Binary input

Positioners can be optionally fitted with a binary input. The following actions can be triggered by changing the edge state:

- **Transmit switching state** [default]
The switching state of the binary input is logged.
- **Set on-site operation write protection**
While the binary input is active, no settings can be changed at the positioner. Enabling configuration over Code 3 is not active.

– Switch between AUTO/MAN

The positioner changes from the automatic mode  (AUTO) to the manual mode  (MAN) or vice versa.

This function is not performed if the positioner is in the fail-safe position mode (SAFE).

- Various diagnostic functions ► EB 8389 (EXPERTplus valve diagnostics)



Note:

- The optional binary input can only be configured using the TROVIS-VIEW software and using the DD parameters (► EB 8389 on EXPERTplus valve diagnostics).
- The default switching state is with an open switch.

3.2 Communication

The positioner is equipped with an interface for HART® protocol (Highway Addressable Remote Transducer) for communication purposes. Data are transmitted in a superimposed frequency (FSK = Frequency Shift Keying) on the existing signal loop for the 4 to 20 mA set point.

Either a HART® capable handheld communicator or a computer with FSK modem can be used to establish communication and operate the positioner.

**Note:**

The HART® device revision as well as the indicating and operating modules supported by the Type 3730-3 Positioner can be found on the SAMSON website:

3.2.1 Configuration using the TROVIS-VIEW software

The positioner can be configured with SAMSON's TROVIS-VIEW Configuration and Operator Interface.

The positioner has for this purpose a **serial interface** to allow the RS-232 or USB port of a computer to be connected to it over an adapter cable.

The TROVIS-VIEW software enables the user to easily configure the positioner as well as view process parameters online.

**Note:**

TROVIS-VIEW provides a uniform user interface that allows users to configure and parameterize various SAMSON devices using device-specific database modules. The 3730-3 device module can be downloaded free of charge from our website (www.samson.de at Services > Software > TROVIS-VIEW). Additional information on TROVIS-VIEW (e.g. system requirements) can be found on the SAMSON website and in the Data Sheet ► T 6661.

3.3 Technical data

Type 3730-3 Positioner		The listed technical data may be restricted by the limits of the test certificate for explosion-protected devices.
Valve travel	Adjustable	Direct attachment to Type 3277 Actuator 3.6 to 30 mm
		Attachment according to IEC 60534-6 (NAMUR) 3.6 to 300 mm
		Attachment according to VDI/VDE 3847 3.6 to 300 mm
		Attachment to rotary actuators (VDI/VDE 3845) 24 to 100° opening angle
Travel range	Adjustable	Adjustable within the initialized travel/angle of rotation of the valve; travel can be restricted to 1/5 at the maximum.
Set point w	Signal range	4 to 20 mA · Two-wire device, reverse polarity protection · Minimum span 4 mA
	Static destruction limit	100 mA
Minimum current		3.6 mA for display · 3.8 mA for operation
Load impedance		≤ 8.2 V (corresponds to 410 Ω at 20 mA)
Supply air	Pressure	1.4 to 7 bar (20 to 105 psi)
	Air quality acc. to ISO 8573-1	Max. particle size and density: Class 4 · Oil content: Class 3 · Pressure dew point: Class 3 or at least 10 K below the lowest ambient temperature to be expected
Signal pressure (output)		0 bar up to the capacity of the supply pressure · Can be limited to 1.4 bar/2.4 bar/3.7 bar ± 0.2 bar by software
Characteristic	Adjustable	Linear/Equal percentage/Reverse equal percentage User-defined (over operating software and communication) Butterfly valve, rotary plug valve and segmented ball valve: Linear/equal percentage
	Deviation	≤ 1 %
Hysteresis		≤ 0.3 %
Sensitivity		≤ 0.1 %
Transit time		Venting or filling with air adjustable separately up to 240 s by software
Direction of action		Reversible
Air consumption, steady state		Independent of supply air approx. 110 l _n /h
Air output capacity	Actuator filled with air	At Δp = 6 bar: 8.5 m _n ³ /h · At Δp = 1.4 bar: 3.0 m _n ³ /h · K _{vmax(20 °C)} = 0.09
	Actuator vented	At Δp = 6 bar: 14.0 m _n ³ /h · At Δp = 1.4 bar: 4.5 m _n ³ /h · K _{vmax(20 °C)} = 0.15
Permissible ambient temperature		-20 to +80 °C All versions -45 to +80 °C With metal cable gland -25 to +80 °C With inductive limit switch (SJ2-S1N) and metal cable gland The listed technical data may be restricted by the limits of the test certificate for explosion-protected devices.

Type 3730-3 Positioner		The listed technical data may be restricted by the limits of the test certificate for explosion-protected devices.	
Influences	Temperature	≤0.15 %/10 K	
	Supply air	None	
	Effect of vibration	≤ 0.25 % up to 2000 Hz and 4 g according to IEC 770	
Electromagnetic compatibility		Complying with EN 61000-6-2, EN 61000-6-3, EN 61326-1 and NAMUR Recommendation NE 21	
Electrical connections		One M20 x 1.5 cable gland for 6 to 12 mm clamping range Second M20 x 1.5 threaded connection additionally available Screw terminals for 0.2 to 2.5 mm ² wire cross-section	
Degree of protection		IP 66/NEMA 4X	
Use in safety-instrumented systems (SIL)		Observing the requirements of IEC 61508, the systematic capability of the pilot valve for emergency venting as a component in safety-instrumented systems is given.	
Emergency venting at 0 mA set point and using optional solenoid valve		Use is possible on observing the requirements of IEC 61511 and the required hardware fault tolerance in safety-instrumented systems up to SIL 2 (single device/HFT = 0) and SIL 3 (redundant configuration/HFT = 1).	
Explosion protection		See Table Summary of explosion protection certificates for Type 3730-3 Positioner	
Communication (local)		SAMSON SSP interface and serial interface adapter	
Software requirements (SSP)		TROVIS-VIEW with database module 3730-3	
Communication (HART®)		HART® field communication protocol Impedance in HART® frequency range: Receiving 350 to 450 Ω · Sending approx. 115 Ω	
Software requirements	For handheld communicator	Device description for Type 3730-3	
	For computer	DTM file according to specification 1.2, suitable for integrating the device into frame applications that support the use of FDT/DTM (e.g. PACTware); other integrations (e.g. AMS, PDM) available	
Binary contacts			
For connection to		Binary input of the PLC acc. to IEC 61131-2, P _{max} = 400 mW or for connection to NAMUR switching amplifier acc. to EN 60947-5-6	NAMUR switching amplifier acc. to EN 60947-5-6
Two software limit switches, reverse polarity protection, floating, configurable switching characteristics (default settings in table)			
Signal state	Version	No explosion protection	Ex
	No response	Effectively non-conducting	≤1.0 mA
	Response	Conductive (R = 348 Ω)	≥2.2 mA
One fault alarm contact, floating			
Signal state	Version	No explosion protection	Ex
	No fault alarm	Conductive (R = 348 Ω)	≥2.2 mA
	Fault alarm	Effectively non-conducting	≤1.0 mA







Design and principle of operation



Type 3730-3 Positioner	The listed technical data may be restricted by the limits of the test certificate for explosion-protected devices.
Materials	
Housing	Die-cast aluminum EN AC-AlSi12(Fe) (EN AC-44300) acc. to DIN EN 1706 · Chromated and powder paint coated · Special version: stainless steel 1.4581
External parts	Stainless steel 1.4571 and 1.4301
Cable gland	M20 x 1.5, black polyamide
Weight	Die-cast aluminum housing: approx. 1.0 kg Stainless steel housing: approx. 2.2 kg
Compliance	
	

Options for Type 3730-3 Positioner	
Solenoid valve · Approval acc. to IEC 61508/SIL	
Input	24 V DC · Reverse polarity protection · Static destruction limit 40 V Current consumption $I = \frac{U - 5.7 \text{ V}}{3840 \Omega}$ (corresponding to 4.8 mA at 24 V/114 mW)
Signal '0' (no response)	<12 V (emergency shutdown at 0 V)
Signal '1' (response)	> 19 V
Service life	> 5 x 10 ⁶ switching cycles
K _v coefficient	0.15
Analog position transmitter	
Power supply	12 to 30 V DC · Reverse polarity protection · Static destruction limit 40 V
Output signal	4 to 20 mA
Operating direction	Reversible
Operating range	-10 to +114 %
Characteristic	Linear
Hysteresis	Same as positioner
High-frequency influence	Same as positioner
Other influences	Same as positioner
Fault alarm	Can be issued as current signal 2.4 ±0.1 mA or 21.6 ±0.1 mA
Pepperl+Fuchs inductive limit switch	
For connection to switching amplifier according to EN 60947-5-6. Can be used in combination with a software limit switch	
SJ2-SN proximity switch	Measuring plate not detected: ≥3 mA · Measuring plate detected: ≤1 mA
SJ2-S1N proximity switch	Measuring plate not detected: ≤1 mA · Measuring plate detected: ≥3 mA

Options for Type 3730-3 Positioner		
External position sensor		
Valve travel	Same as positioner	
Cable	10 m · Flexible and durable · With M12x1 connector · Flame-retardant acc. to VDE 0472 Resistant to oils, lubricants and coolants as well as other aggressive media	
Permissible ambient temperature	-60 to +105 °C with fixed connection between the positioner and position sensor · The limits in the test certificate additionally apply for explosion-protected versions	
Immunity to vibration	Up to 10 g in the range of 10 to 2000 Hz	
Degree of protection	IP 67	
Leakage sensor · Suitable for operation in hazardous areas		
Temperature range	-40 to +130 °C	
Tightening torque	20 ±5 Nm	
Binary input · Galvanically isolated · Switching behavior configured over software (e.g. TROVIS-VIEW, DTM)		
Active switching behavior (default setting)		
Connection	For external switch (floating contact) or relay contact	
Electric data	Open-circuit voltage when contact is open: max. 10 V Pulsed DC current reaching peak value of 100 mA and RMS value of 0.01 mA when contact is closed	
Contact	Closed, $R < 20 \Omega$	ON switching state (default setting)
	Open, $R > 400 \Omega$	OFF switching state (default setting)
Passive switching behavior		
Connection	For externally applied DC voltage, reverse polarity protection	
Electric data	3 to 30 V · Static destruction limit 40 V · Current consumption 3.7 mA at 24 V	
Voltage	> 6 V	ON switching state (default setting)
	<1 V	OFF switching state (default setting)
Analog input x · Galvanically isolated · Input for externally measured valve position		
Input signal	4 to 20 mA · Reverse polarity protection · Minimum span 6.4 mA	
Electric data	Load impedance at 20 mA: 6.0 V · Impedance at 20 mA: 300 Ω · Overload capacity: 24 V AC/DC	

Summary of explosion protection certificates for Type 3730-3 Positioner

Type	Certification	Type of protection/comments
-3	INMETRO On request	
	STCC Number 972 Valid until 2017-10-01	0Ex ia IIC T6X; 2Ex s II T6X
	CCoE Number A/P/HQ/MH/104/1105 Date 2011-01-27 Valid until 2016-01-26	Ex ia IIC T6
3730 -31	 EU type examination certificate Number PTB 02 ATEX 2174 Date 2014-10-14	II 2 G Ex ia IIC Gb; II 2 D Ex ia IIIC T80°C Db
	 Number RU C-DE08.B.00113 Date 2013-11-15 Valid until 2018-11-14	1Ex ia IIC T6/T5/T4 Gb X; Ex tb IIIC T80°C Db X
	 Number IECEX PTB 05.0008 Date 2005-02-21	Ex ia IIC T6/T5/T4
	KCS Number 11-KB4BO-0224 Date 2011-11-10 Valid until 2015-11-10	Ex ia IIC T6/T5/T4
	 Number GYJ12.1486X Date 2012-10-08 Valid until 2017-10-07	Ex ia IIC T4~T6 Ga
	 Number 1330129 Date 2009-02-19	Ex ia IIC T6; Class I, Zone 0; Class I, Groups A, B, C, D; Class II, Groups E, F, G; Class I, Zone 2; Class I, Div.2, Groups A, B, C, D; Class II, Div.2, Groups E, F, G
-33	 Number 3012394 Date 2008-11-30	Class I, Zone 0 AEx ia IIC; Class I, II, III, Div.1, Groups A, B, C, D, E, F, G; Class I, Div.2, Groups A, B, C, D; Class II, Div.2, Groups F, G
	 EU type examination certificate Number PTB 02 ATEX 2174 Date 2014-10-14	II 2 D Ex tb IIIC T80°C Db
-35		

Type	Certification	Type of protection/comments
3730 -38	 Statement of conformity Number PTB 03 ATEX 2180 X Date 2013-07-30	II 3G Ex nA II T6; II 3G Ex ic IIC T6; II 3D Ex tc IIIC T80°C IP66
	 Number RU C-DE08.B.00113 Date 2013-11-15 Valid until 2018-11-14	2Ex nA IIC T6/T5/T4 Gc X; 2Ex ic IIC T6/T5/T4 Gc X; Ex tc IIIC T80°C Dc X
	 Number GYJ12.1487X Date 2012-10-08 Valid until 2017-10-07	Ex nL IIC T4~T6 Gc; Ex nA IIC T4~T6 Gc

4 Attachment to the control valve – Mounting parts and accessories



NOTICE

Risk of malfunction due to incorrect sequence of mounting, installation and start-up!

Keep the following sequence.

1. Remove the protective film from the pneumatic connections.
2. Mount the positioner on the control valve.
3. Connect the supply air.
4. Connect the electrical power.
5. Perform the start-up settings.

The positioner is suitable for the following types of attachment:

- Direct attachment to SAMSON Type 3277 Actuator
- Attachment to actuators according to IEC 60534-6 (NAMUR)
- Attachment according to VDI/VDE 3847
- Attachment to Type 3510 Micro-flow Valve
- Attachment to rotary actuators



NOTICE

Risk of malfunction due to incorrect mounting parts/accessories or incorrect assignment of lever and pin position.

Attach the positioner to the control valve only using the mounting parts and accessories as specified in Table 1 to Table 6. Observe the type of attachment.

Observe the assignment between lever and pin position (see travel tables on page 21).

Lever and pin position

The positioner is adapted to the actuator and to the rated travel by the lever on the back of the positioner and the pin inserted into the lever.

The travel tables on page 21 show the maximum adjustment range at the positioner. The travel that can be implemented at the valve is additionally restricted by the selected fail-safe position and the required compression of the actuator springs.

The positioner is equipped with the M lever (pin position 35) as standard.

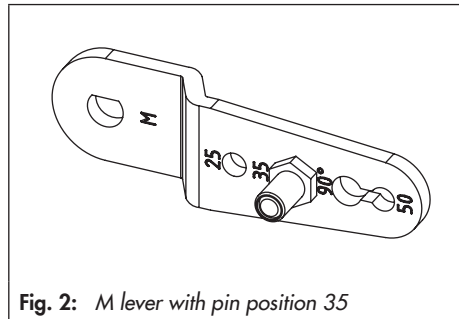

Fig. 2: M lever with pin position 35



NOTICE

Risk of malfunction because the newly mounted lever has not been adapted to the internal measuring lever.

Move the newly mounted lever (1) once all the way as far as it will go in both directions.

Travel tables

**Note:**

The **M** lever is included in the scope of delivery.

S, L, XL levers for attachment according to IEC 60534-6 (NAMUR) are available as accessories (see Table 3). The **XXL** lever is available on request.

Direct attachment to Type 3277-5 and Type 3277 Actuators

Actuator size [cm ²]	Rated travel [mm]	Adjustment range at positioner ¹⁾ Travel [mm]	Required lever	Assigned pin position
120	7.5	5.0 to 25.0	M	25
120/175/240/350	15	7.0 to 35.0	M	35
355/700/750	30	10.0 to 50.0	M	50

Attachment according to IEC 60534-6 (NAMUR)

SAMSON valves with Type 3271 Actuator		Adjustment range at positioner ¹⁾ Other control valves		Required lever	Assigned pin position
Actuator size [cm ²]	Rated travel [mm]	Min. travel [mm]	Max. travel [mm]		
60 and 120 with Type 3510 Valve	7.5	3.6	18.0	S	17
120	7.5	5.0	25.0	M	25
120/175/240/350	15	7.0	35.0	M	35
700/750	7.5				
355/700/750	15 and 30	10.0	50.0	M	50
1000/1400/2800	30	14.0	70.0	L	70
	60	20.0	100.0	L	100
1400/2800	120	40.0	200.0	XL	200
See manufacturer's specifications	200	See manufacturer's specifications		XXL	300

Rotary actuators Opening angle	Required lever	Assigned pin position
24 to 100°	M	90°

¹⁾ The min./max. adjustment range is based on the **NOM (nominal range)** initialization mode

4.1 Direct attachment

4.1.1 Type 3277-5 Actuator

- Required mounting parts and accessories: Table 1 on page 50
- Observe the travel table on page 21.

Actuator with 120 cm² (see Fig. 3)

Depending on the type of positioner attachment, the signal pressure is routed either left or right of the yoke through a hole to the actuator diaphragm. Depending on the fail-safe action of the actuator "actuator stem extends" or "actuator stem retracts" (valve closes or opens upon supply air failure), the switchover plate (9) must first be attached to the actuator yoke. Align the switchover plate with the corresponding symbol for left or right attachment according to the marking (view looking onto the switchover plate).

1. Mount connecting plate (6) or pressure gauge bracket (7) with pressure gauges on the positioner, making sure the two seals are seated properly.
2. Remove screw plug (4) on the back of the positioner and seal the signal pressure output (38) on the connecting plate (6) or on the pressure gauge bracket (7) with the stopper (5) included in the accessories.
3. Place follower clamp (3) on the actuator stem, align it and screw tight so that the mounting screw is located in the groove of the actuator stem.
4. Mount cover plate (10) with narrow side of the cut-out (Fig. 3, on the left) pointing towards the signal pressure connection.

Make sure that the gasket (14) points towards the actuator yoke.

5. **15 mm travel:** Keep the follower pin (2) on the **M** lever (1) on the back of the positioner in the pin position **35** (delivered state).
7.5 mm travel: Remove the follower pin (2) from the pin position **35**, reposition it in the hole for pin position **25** and screw tight.
6. Insert formed seal (15) into the groove of the positioner housing and insert the seal (10.1) on the back of the housing.
7. Place positioner on the cover plate (10) in such a manner that the follower pin (2) rests on the top of the follower clamp (3). Adjust the lever (1) correspondingly and open the positioner cover to hold the positioner shaft in position at the cap or rotary pushbutton. The lever (1) must rest on the follower clamp with spring force. Mount the positioner on the cover plate (10) using the two fixing screws.



Note applying to all types of attachment except for direct attachment to Type 3277-5:

The signal pressure output at the back must be sealed by the screw plug (4, order no. 0180-1254) and the associated O-ring (order no. 0520-0412).

8. Mount cover (11) on the other side. Make sure that the vent plug is located at the bottom when the control valve is installed to allow any condensed water that collects to drain off.

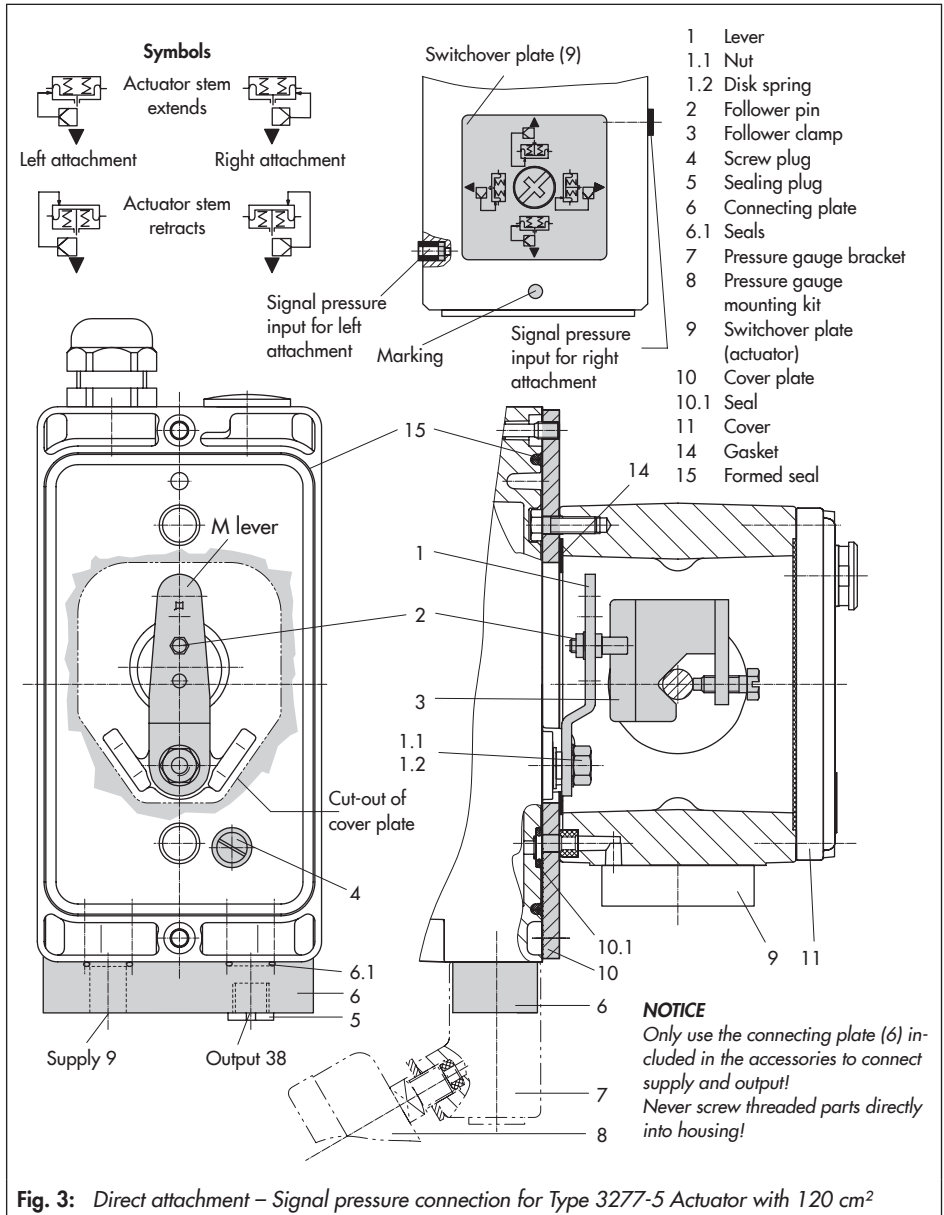

Fig. 3: Direct attachment – Signal pressure connection for Type 3277-5 Actuator with 120 cm²

4.1.2 Type 3277 Actuator

- Required mounting parts and accessories: Table 2 on page 51
- Observe the travel table on page 21.

Actuators with 175 to 750 cm² effective areas (see Fig. 4)

Mount the positioner on the yoke. The signal pressure is routed to the actuator over the connection block (12), for actuators with fail-safe action "actuator stem extends" internally through a hole in the valve yoke and for "actuator stem retracts" through an external pipe.

1. Place follower clamp (3) on the actuator stem, align it and screw tight so that the mounting screw is located in the groove of the actuator stem.
2. Mount cover plate (10) with narrow side of the cut-out (Fig. 4, on the left) pointing towards the signal pressure connection. Make sure that the gasket (14) points towards the actuator yoke.
3. For actuators with 355, 700 or 750 cm², remove the follower pin (2) on the **M** lever (1) on the back of the positioner from pin position **35**, reposition it in the hole for pin position **50** and screw tight. For actuators 175, 240 and 350 cm² with 15 mm travel, keep the follower pin (2) in pin position **35**.
4. Insert formed seal (15) into the groove of the positioner housing.
5. Place positioner on the cover plate in such a manner that the follower pin (2) rests on the top of the follower clamp (3).

Adjust the lever (1) correspondingly and open the positioner cover to hold the positioner shaft in position at the cap or rotary pushbutton. The lever (1) must rest on the follower clamp with spring force. Mount the positioner on the cover plate (10) using the two fixing screws.

6. Make sure that the tip of the gasket (16) projecting from the side of the connection block is positioned to match the actuator symbol for the actuator's fail-safe action "actuator stem extends" or "actuator stem retracts". If this is not the case, unscrew the three fastening screws and lift off the cover. Turn the gasket (16) by 180° and re-insert it. The old connection block version (Fig. 4, bottom) requires the switch plate (13) to be turned to align the actuator symbol with the arrow marking.
7. Place the connection block (12) with the associated seals against the positioner and the actuator yoke and fasten using the screw (12.1). For actuators with fail-safe action "actuator stem retracts", additionally remove the stopper (12.2) and mount the external signal pressure pipe.
8. Mount cover (11) on the other side. Make sure that the vent plug is located at the bottom when the control valve is installed to allow any condensed water that collects to drain off.

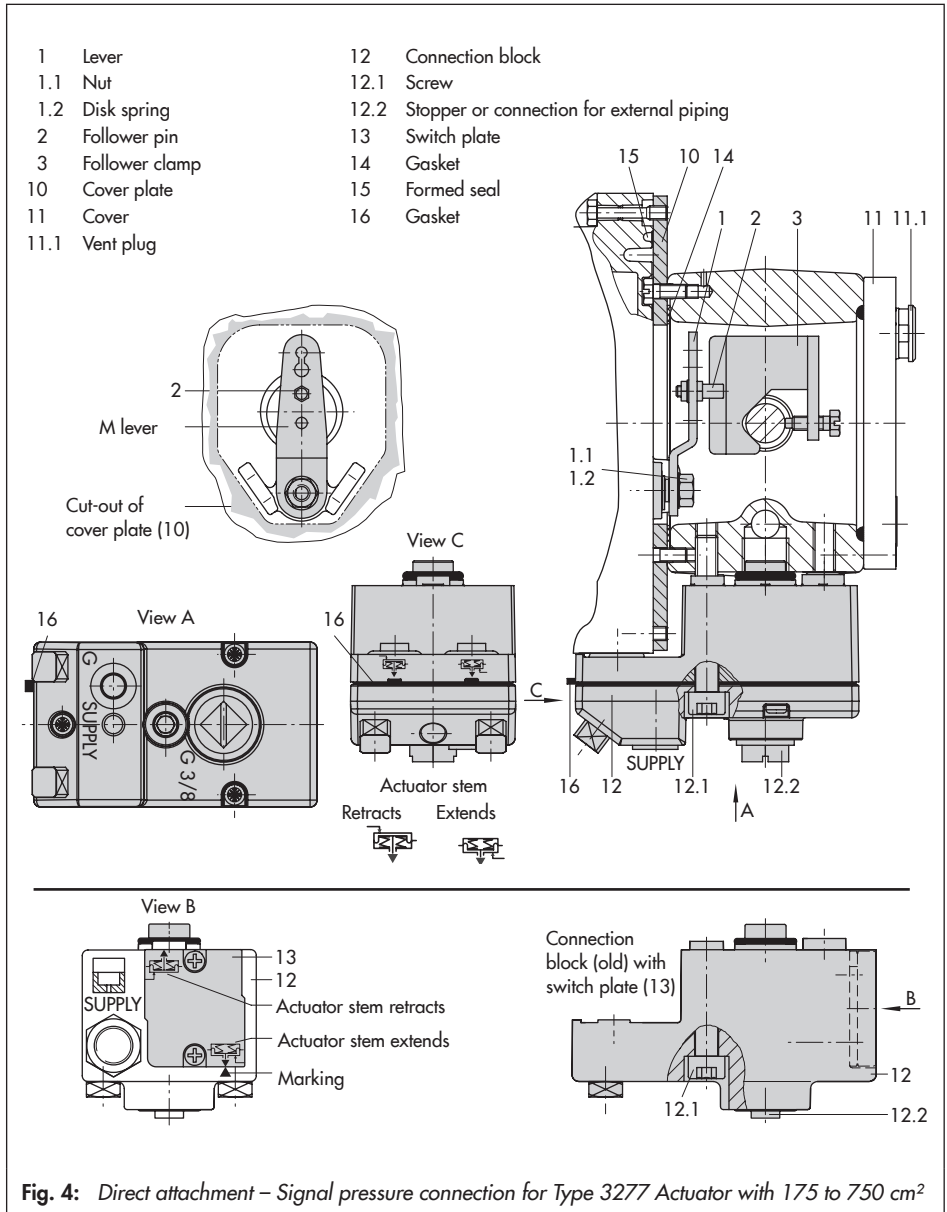

4.2 Attachment according to IEC 60534-6

- Required mounting parts and accessories: Table 3 on page 52
- Observe the travel table on page 21.

Fig. 5

The positioner is attached to the control valve using a NAMUR bracket (10).

1. Screw the two bolts (14) to the bracket (9.1) of the stem connector (9), place the follower plate (3) on top and use the screws (14.1) for fastening.

Actuator sizes 2800 cm² and 1400 cm² with 120 mm travel:

- For a travel of 60 mm or smaller, screw the longer follower plate (3.1) directly to the stem connector (9).
 - For a travel exceeding 60 mm, mount the bracket (16) first and then the follower plate (3) to the bracket together with the bolts (14) and screws (14.1).
2. Mount NAMUR bracket (10) to the control valve as follows:
 - For **attachment to the NAMUR rib**, use an M8 screw (11) and toothed lock washer directly in the yoke hole.
 - For attachment to **valves with rod-type yokes**, use two U-bolts (15) around the yoke. Align the NAMUR bracket (10) according to the embossed scale so that the follower plate (3) is shifted by half the angle range to the NAMUR bracket (the slot of the follower plate is centrally

aligned with the NAMUR bracket at mid valve travel).

3. Mount connecting plate (6) or pressure gauge bracket (7) with pressure gauges on the positioner, making sure the two seals (6.1) are seated properly.
4. Select required lever size (1) **M**, **L** or **XL** and pin position according to the actuator size and valve travel listed in the travel table on page 21.

Should a pin position other than position **35** with the standard **M** lever be required, or an **L** or **XL** lever size be required, proceed as follows:

5. Screw the follower pin (2) in the assigned lever hole (pin position as specified in the travel table). Only use the longer follower pin (2) included in the mounting kit.
6. Place the lever (1) on the shaft of the positioner and fasten it tight using the disk spring (1.2) and nut (1.1). Move lever once all the way as far as it will go in both directions.
7. Place positioner on the NAMUR bracket in such a manner that the follower pin (2) rests in the slot of the follower plate (3, 3.1). Adjust the lever (1) correspondingly.
Screw the positioner to the NAMUR bracket using both its mounting screws.

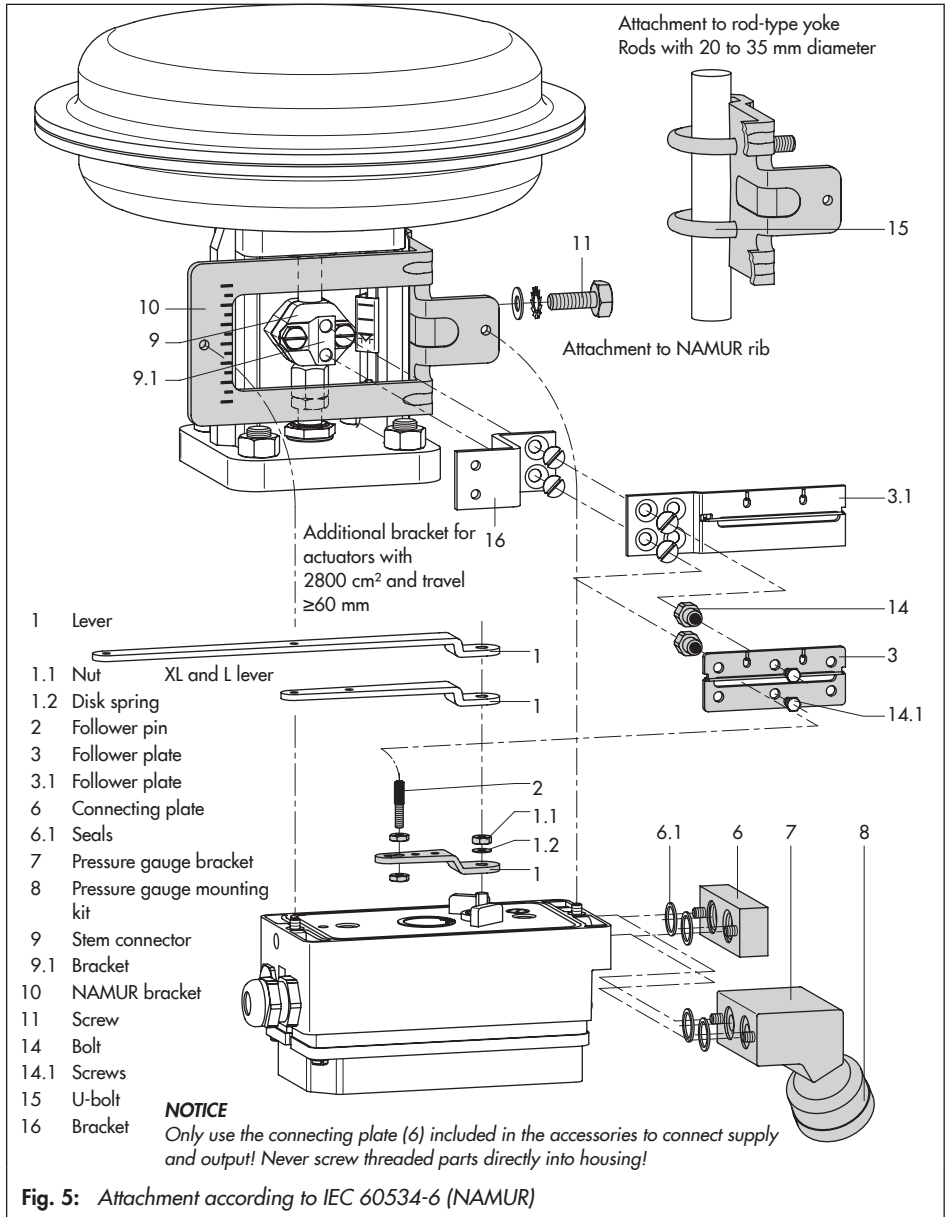

4.3 Attachment according to VDI/VDE 3847

Type 3730-3xxx0xxxx0x0060xx and Type 3730-3xxx0xxxx0x0070xx Positioners with air purging of the actuator's spring chamber can be attached according to VDI/VDE 3847.

Type 3730-3xxx0xxxx0x0000xx Positioner without air purging of the actuator's spring chamber can be attached according to VDI/VDE 3847.

This type of attachment allows the positioner to be replaced quickly while the process is running by blocking the air in the actuator.

The signal pressure can be blocked in the actuator by unscrewing the red retaining screw (20) and then turning the air blocker (19) on the bottom of the adapter block.

Attachment to Type 3277 Actuator (see Fig. 6)

– Required mounting parts and accessories: Table 4 on page 52

Mount the positioner on the yoke as shown in Fig. 6. The signal pressure is routed to the actuator over the connecting plate (12), for actuators with fail-safe action "actuator stem extends" internally through a bore in the valve yoke and for "actuator stem retracts" through external piping.

Only the Y1 port is required for positioner attachment. The Y2 port can be used for air purging of the spring chamber.

1. Place follower clamp (3) on the actuator stem, align it and screw tight so that the

mounting screw is located in the groove of the actuator stem.

2. Place the adapter bracket (6) on the positioner and mount using the screws (6.1). Make sure that the seals are correctly seated. For positioners **with air purging**, remove the stopper (5) before mounting the positioner. For positioners **without air purging**, replace the screw plug (4) with a vent plug.
3. For actuators with 355, 700 or 750 cm², remove the follower pin (2) on the M lever (1) on the back of the positioner from pin position 35, reposition it in the hole for pin position 50 and screw tight.

For actuators 175, 240 and 350 cm² with 15 mm travel, keep the follower pin (2) in pin position 35.

4. Insert the formed seal (6.2) in the groove of the adapter bracket (6).
5. Insert the formed seal (17.1) into the turnboard (17) and mount the turnboard to the adapter block (13) using the screws (17.2).
6. Mount the blank plate (18) to the turnboard (17) using the screws (18.1). Make sure that the seals are correctly seated.



Note:

A solenoid valve can also be mounted in place of the blank plate (18). The orientation of the turnboard (17) determines the mounting position of the solenoid valve. Alternatively, a restrictor plate can be mounted (► AB 11).

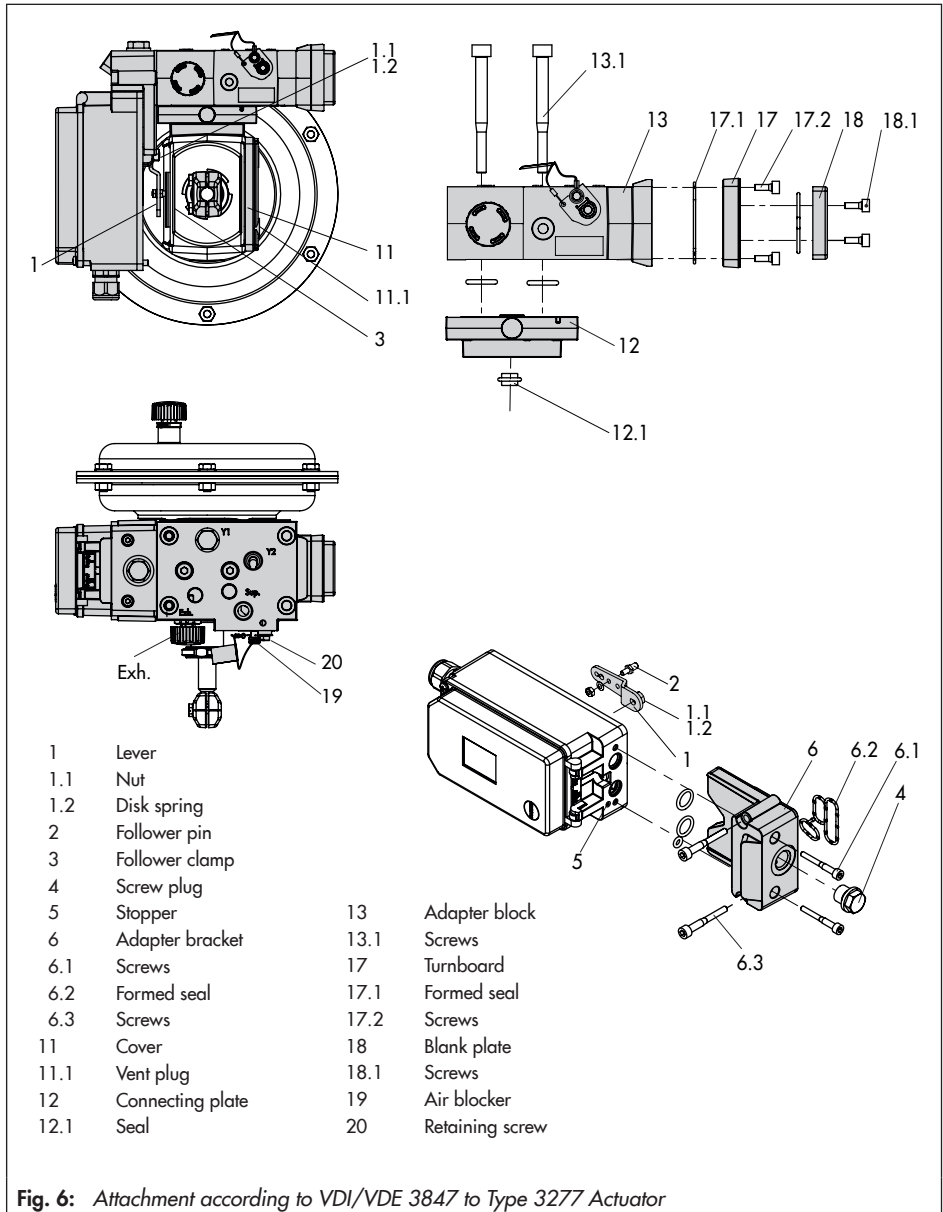
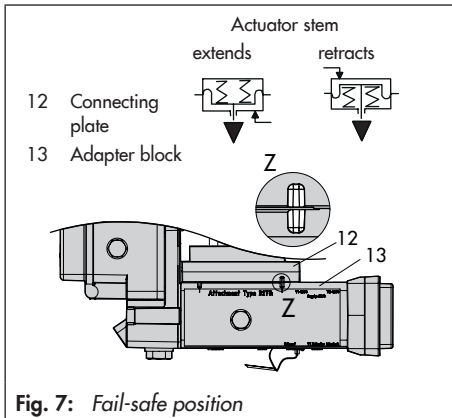

Fig. 6: Attachment according to VDI/VDE 3847 to Type 3277 Actuator

7. Insert the screws (13.1) through the middle holes of the adapter block (13).
8. Place the connecting plate (12) together with the seal (12.1) onto the screws (13.1) corresponding to the fail-safe action "actuator stem extends" or "actuator stem retracts". The fail-safe action that applies is determined by aligning the groove of the adapter block (13) with the groove of the connecting plate (12) (Fig. 7).



9. Mount the adapter block (13) together with the connecting plate (12) to the actuator using the screws (13.1).
10. Insert the vent plug (11.1) into the **Exh.** connection.
11. For fail-safe action "actuator stem extends", seal the Y1 port with a blanking plug.
For fail-safe action "actuator stem retracts", connect the Y1 port to the signal pressure connection of the actuator.

Place positioner on the adapter block (13) in such a manner that the follower pin (2) rests on the top of the follower clamp (3). Adjust the lever (1) correspondingly and open the positioner cover to hold the positioner shaft in position at the cap or rotary pushbutton.

The lever (1) must rest on the follower clamp with spring force.

Fasten the positioner to the adapter block (13) using the two fixing screws (6.3). Make sure the formed seal (6.2) is properly seated.

12. Mount cover (11) on the other side to the yoke. Make sure that the vent plug is located at the bottom when the control valve is installed to allow any condensed water that collects to drain off.

Attachment to NAMUR rib (see Fig. 8)

- Required mounting parts and accessories: Table 4 on page 52
- Observe the travel table on page 21.

1. **Series 240 Valves, actuator size up to 1400-60 cm²:** Screw the two bolts (14) to the bracket of the stem connector or directly to the stem connector (depending on the version), place the follower plate (3) on top and use the screws (14.1) to fasten it.

Type 3251 Valve, 350 to 2800 cm²:

Screw the longer follower plate (3.1) to the bracket of the stem connector or directly to the stem connector (depending on the version).

Type 3254 Valve, 1400-120 to

2800 cm²: Screw the two bolts (14) to the bracket (16). Fasten the bracket (16) onto the stem connector, place the follower plate (3) on top and use the screws (14.1) to fasten it.

Mount the positioner on the NAMUR rib as shown in Fig. 8.

2. For **attachment to the NAMUR rib**, fasten the NAMUR connection block (10) directly into the existing yoke bore using the screw and toothed lock washer (11). Align the marking on the NAMUR valve connection (on the side marked '1') to 50 % travel.
For attachment to **valves with rod-type yokes** using the formed plate (15), which is placed around the yoke: screw the four studs into the NAMUR connection block (10). Place the NAMUR connection block

on the rod and position the formed plate (15) on the opposite side. Use the nuts and toothed lock washers to fasten the formed plate onto the studs. Align the marking on the NAMUR valve connection (on the side marked '1') to 50 % travel.

3. Place the adapter bracket (6) on the positioner and mount using the screws (6.1). Make sure that the seals are correctly seated. For positioners **with air purging**, remove the stopper (5) before mounting the positioner. For positioners **without air purging**, replace the screw plug (4) with a vent plug.
4. Select required lever size (1) M, L or XL and pin position according to the actuator size and valve travel listed in the travel table on page 21.

Should a pin position other than position 35 with the standard M lever be required, or an L or XL lever size be required, proceed as follows:

- Screw the follower pin (2) in the assigned lever hole (pin position as specified in the travel table). Only use the longer follower pin (2) included in the mounting kit.
- Place the lever (1) on the shaft of the positioner and fasten it tight using the disk spring (1.2) and nut (1.1).
- Move lever once all the way as far as it will go in both directions.

5. Insert the formed seal (6.2) in the groove of the adapter bracket.
6. Insert the formed seal (17.1) into the turnboard (17) and mount the turnboard to the adapter block (13) using the screws (17.2).
7. Mount the blank plate (18) to the turnboard using the screws (18.1). Make sure that the seals are correctly seated.



Note:

A solenoid valve can also be mounted in place of the blank plate (18). The orientation of the turnboard (17) determines the mounting position of the solenoid valve. Alternatively, a restrictor plate can be mounted (► AB 11).

8. Fasten the adapter block (13) to the NAMUR connection block using the screws (13.1).
9. Insert the vent plug into the Exh. connection.
10. Place the positioner on the adapter block (13) in such a manner that the follower pin (2) rests on the top of the follower plate (3, 3.1). Adjust the lever (1) correspondingly.
Fasten the positioner to the adapter block (13) using the two fixing screws (6.3). Make sure the formed seal (6.2) is properly seated.
11. For **single-acting actuators without air purging**, connect the Y1 port of the adapter block to the signal pressure con-

nection of the actuator. Seal the Y2 port with a blanking plug.

For **double-acting actuators and actuators with air purging**, connect the Y2 port of the adapter block to the signal pressure connection of the second actuator chamber or spring chamber of the actuator.

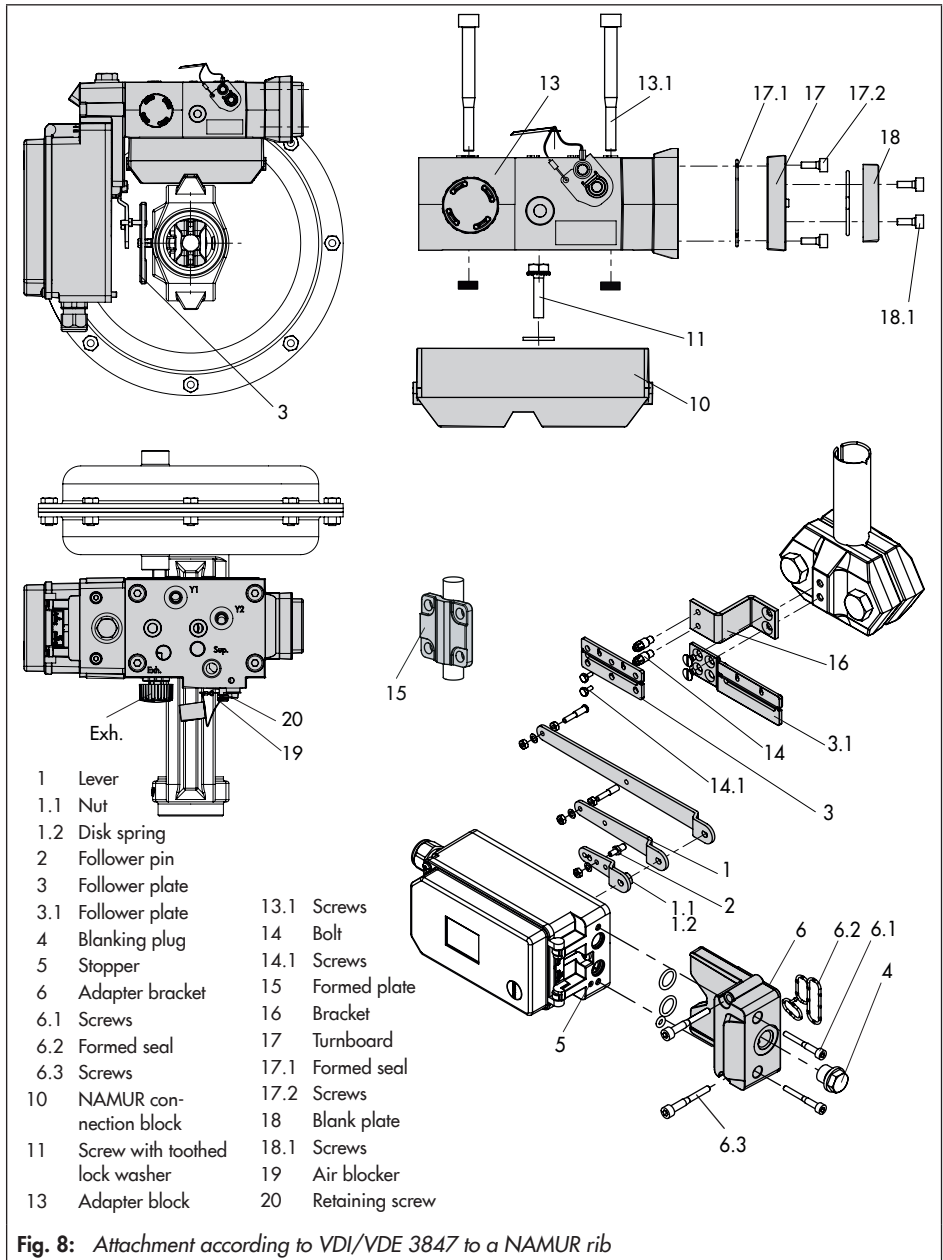

Fig. 8: Attachment according to VDI/VDE 3847 to a NAMUR rib

4.4 Attachment to Type 3510 Micro-flow Valve

Fig. 9

- Required mounting parts and accessories: Table 3 on page 52
- Observe the travel table on page 21.

The positioner is attached to the valve yoke using a bracket.

1. Fasten the bracket (9.1) to the stem connector.
2. Screw the two bolts (9.2) to the bracket (9.1) of the stem connector (9), place the follower plate (3) on top and use the screws (9.3) for fastening.
3. Mount the travel indication scale (accessories) to the outer side of the yoke using the hex screws (12.1), ensuring that the scale is aligned with the stem connector.
4. Fasten the hex bar (11) onto the outer side of yoke by screwing the M8 screws (11.1) directly into the holes on the yoke.
5. Fasten the bracket (10) to the hex bar (11) using the hex screw (10.1), washer and tooth lock washer.
6. Mount connecting plate (6) or pressure gauge bracket (7) with pressure gauges on the positioner, making sure the two seals are seated properly.
7. Unscrew the standard M lever (1) including follower pin (2) from the positioner shaft.
8. Take the S lever (1) and screw the follower pin (2) in the hole for pin position 17.

9. Place the S lever on the positioner shaft and screw tight using the disk spring (1.2) and nut (1.1).
Move lever once all the way as far as it will go in both directions.
10. Place positioner on the bracket (10) in such a manner that the follower pin slides into the groove of the follower pin (3). Adjust the lever (1) correspondingly. Screw the positioner to the bracket (10) using both its screws.

4.5 Attachment to rotary actuators

Fig. 11

- Required mounting parts and accessories: Table 5 on page 53
- Observe the travel table on page 21.

The positioner is mounted to the rotary actuator using two pairs of brackets.

Prior to attaching the positioner to the SAMSON Type 3278 Rotary Actuator, mount the associated adapter (5) to the free end of the rotary actuator shaft.



Note:

On attaching the positioner as described below, it is imperative that the actuator's direction of rotation is observed.

1. Place follower clamp (3) on the slotted actuator shaft or adapter (5).

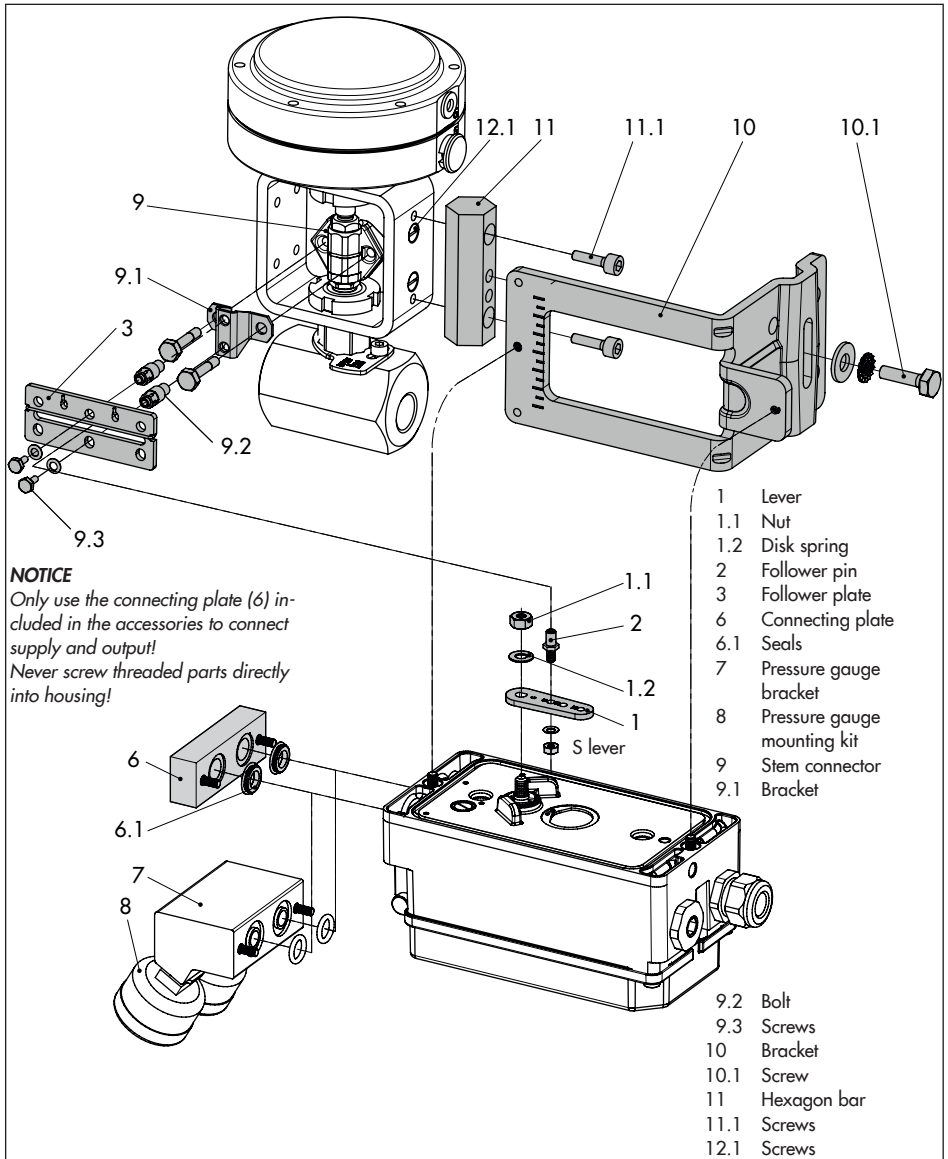

Fig. 9: Attachment to Type 3510 Micro-flow Valve

2. Place coupling wheel (4) with flat side facing the actuator on the follower clamp (3). Refer to Fig. 11 to align slot so that it matches the direction of rotation when the valve is in its closed position.
3. Fasten the coupling wheel (4) and follower clamp (3) tightly onto the actuator shaft using screw (4.1) and disk spring (4.2).
4. Fasten the bottom pair of brackets (10.1) with the bends pointing either facing to the inside or to the outside (depending on the actuator size) onto the actuator housing. Position the top pair of brackets (10) and fasten.
5. Mount connecting plate (6) or pressure gauge bracket (7) with pressure gauges on the positioner, making sure the two seals are seated properly. **Double-acting** springless rotary actuators require the use of a reversing amplifier on the connection side of the positioner housing (see section 4.6).
6. Unscrew the standard follower pin (2) from the positioner's **M** lever (1). Use the metal follower pin (\varnothing 5 mm) included in the mounting kit and screw tight into the hole for pin position **90°**.
7. Place positioner on the top bracket (10) and fasten tight. Taking the actuator's direction of rotation into account, adjust lever (1) so that it engages in the slot of the coupling wheel (4) with its follower pin (Fig. 11). It must be guaranteed that the lever (1) is parallel to the long side of the positioner when the actuator is at half its angle of rotation.
8. Stick the scale plate (4.3) on the coupling wheel so that the arrow tip indicates the closed position and it can be easily read when the valve is installed.

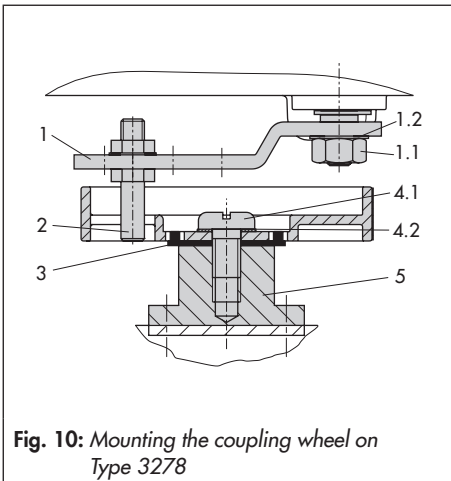

Fig. 10: Mounting the coupling wheel on Type 3278

4.5.1 Heavy-duty version

Fig. 12

- Required mounting parts and accessories: Table 5 on page 53

Both mounting kits contain all the necessary mounting parts. The parts for the actuator size used must be selected from the mounting kit.

Prepare actuator, and mount required adapter supplied by the actuator manufacturer, if necessary.

1. Mount the housing (10) onto the rotary actuator. In case of VDI/VDE attachment,

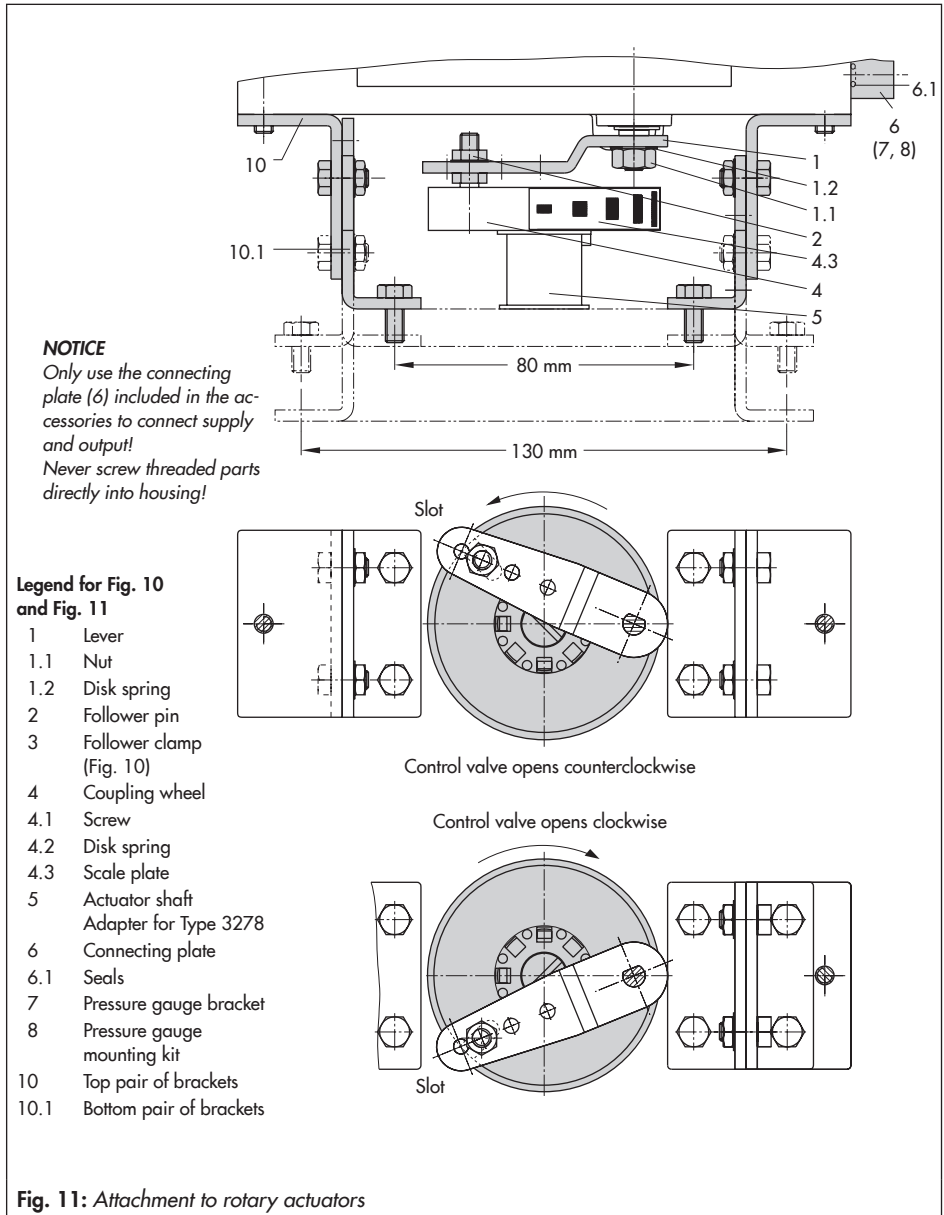

- place spacers (11) underneath, if necessary.
- For **SAMSON Type 3278 and VETEC S160 Rotary Actuators**, screw the adapter (5) onto the free end of the shaft or place adapter (5.1) onto the shaft of the **VETEC R Actuator**. Place adapter (3) onto **Type 3278, VETEC S160 and VETEC R Actuators**. For **VDI/VDE version**, this step depends on the actuator size.
 - Stick adhesive label (4.3) onto the coupling in such a manner that the yellow part of the sticker is visible in the window of the housing when the valve is OPEN. Adhesive labels with explanatory symbols are enclosed and can be stuck on the housing, if required.
 - Fasten coupling (4) on the slotted actuator shaft or adapter (3) using screw (4.1) and disk spring (4.2).
 - Unscrew the standard follower pin (2) from the positioner's M lever (1). Attach the follower pin (\varnothing 5 mm) included in the mounting kit to pin position 90° .
 - Mount connecting plate (6) for required G $\frac{1}{4}$ connecting thread or pressure gauge bracket (7) with pressure gauges on the positioner, making sure the two seals (6.1) are seated properly. Double-acting springless rotary actuators require the use of a reversing amplifier on the connection side of the positioner housing (refer to section 4.6).
 - For actuators with a volume of less than 300 cm³, fit the restriction (order no. 1400-6964) into the signal pressure output of the positioner (or the output of the pressure gauge bracket or connecting plate).
 - Place positioner on housing (10) and screw it tight. Taking the actuator's direction of rotation into account, adjust lever (1) so that it engages in the correct slot with its follower pin (Fig. 13).

4.6 Reversing amplifier for double-acting actuators

For the use with double-acting actuators, the positioner must be fitted with a reversing amplifier, e.g. the SAMSON Type 3710 Reversing Amplifier (see Mounting and Operating Instructions ► EB 8392).

If a different reversing amplifier (item no. 1079-1118 or 1079-1119) is used, follow the mounting instructions described in section 4.6.1.

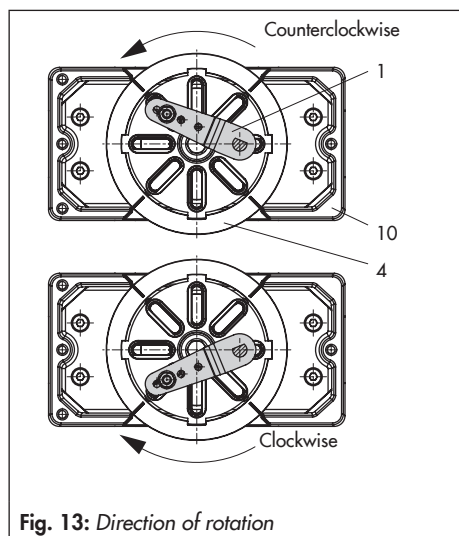

Fig. 13: Direction of rotation

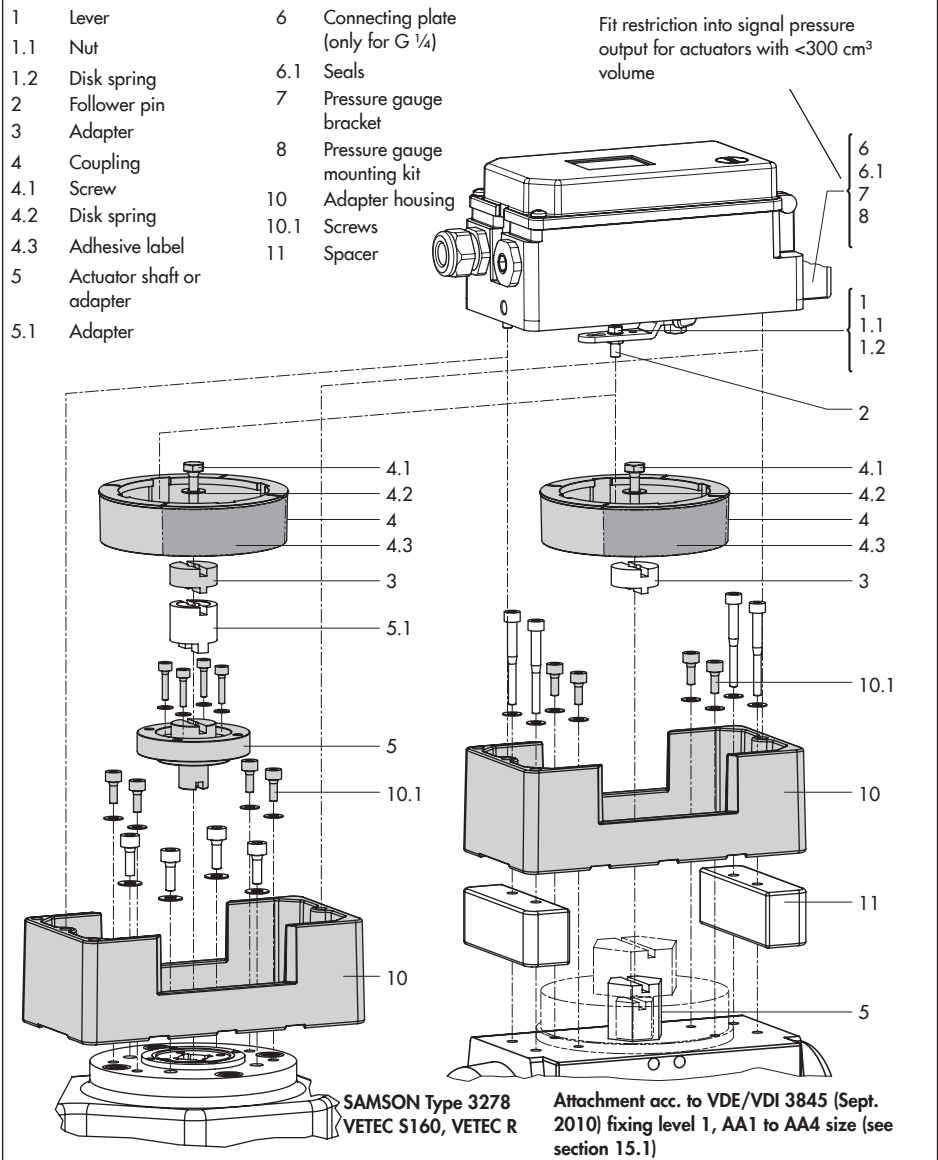

Fig. 12: Attachment to rotary actuators (heavy-duty version)

The following applies to all reversing amplifiers:

The signal pressure of the positioner is supplied at the output 1 of the reversing amplifier. An opposing pressure, which equals the required supply pressure (Z) when added to the pressure at output 1, is applied at output 2.

The following relationship applies:

Output 1 + Output 2 = Supply pressure (Z).

Connect output 1 to the loading pressure connection on the actuator that causes the valve to open when the pressure rises.

Connect output 2 to the loading pressure connection on the actuator that causes the valve to close when the pressure rises.

→ Set slide switch on positioner to AIR TO OPEN.



Note:

How the outputs are marked depends on the reversing amplifier used:

– **Type 3710:** Output 1/2 = Y_1/Y_2

– **1079-1118 and 1079-1119:**

Output 1/2 = A_1/A_2

4.6.1 Reversing amplifier (1079-1118 or 1079-1119)

Fig. 14

1. Mount the connecting plate (6) from the accessories in Table 5 to the positioner. Make sure that both O-rings (6.1) are seated correctly.

2. Thread the special nuts (1.3) from the accessories of the reversing amplifier into the boreholes of the connecting plate.
3. Insert the gasket (1.2) into the recess of the reversing amplifier and slide both the hollowed special screws (1.1) into the connecting boreholes **A₁** and **Z**.
4. Place the reversing amplifier onto the connecting plate (6) and screw tight using both the special screws (1.1).
5. Use a screwdriver (8 mm wide) to screw the enclosed filters (1.6) into the connection boreholes **A₁** and **Z**.



NOTICE

Air can escape uncontrolled from the signal pressure connection.

Do not unscrew the sealing plug (1.5) out of the reversing amplifier.



Note:

The rubber seal (1.4) is not required and can be removed when the sealing plug is used.

6. After initialization, set Code 16 (Pressure limit) to No.

Pressure gauge attachment

The mounting sequence shown in Fig. 14 remains unchanged. Screw a pressure gauge bracket onto the connections **A₁** and **Z**.

Pressure gauge	G 1/4	1400-7106
bracket	1/4 NPT	1400-7107

Pressure gauges for supply air Z and output **A₁** as listed in Table 1 to Table 7.

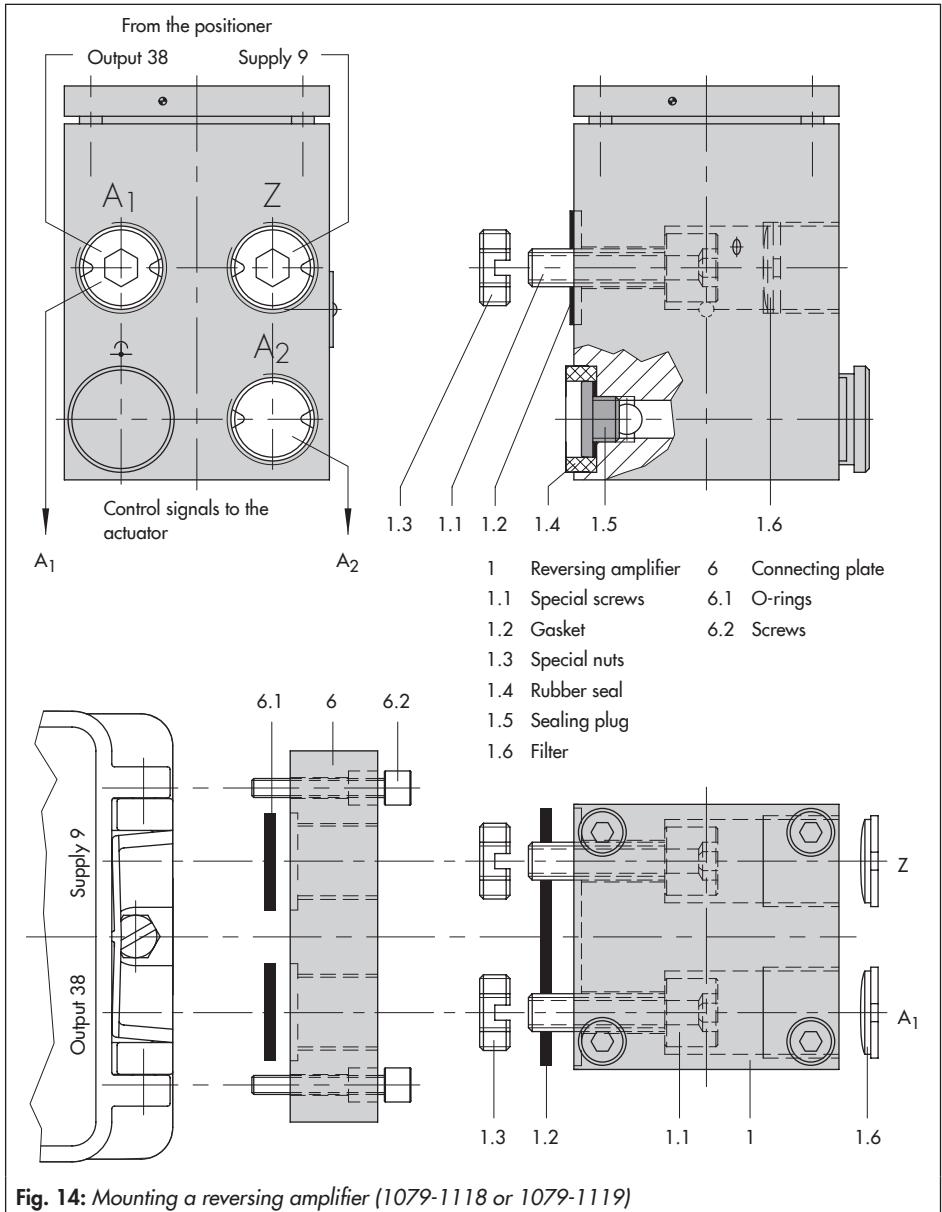

4.7 Attachment of external position sensor

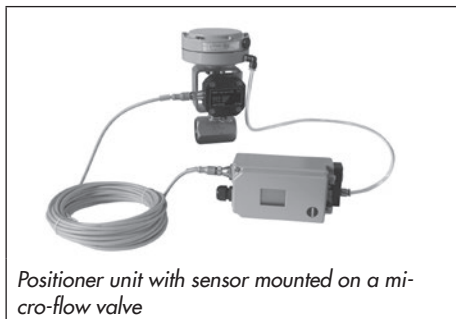

Positioner unit with sensor mounted on a micro-flow valve

- Required mounting parts and accessories: Table 7 on page 54

In the positioner version with an external position sensor, the sensor located in a separate housing is attached over a plate or bracket to the control valve. The travel pick-off corresponds to that of a standard device.

The positioner can be mounted as required to a wall or a pipe.

For the pneumatic connection either a connecting plate (6) or a pressure gauge bracket (7) must be fixed to the housing, depending on the accessory chosen. Make sure the seals (6.1) are correctly inserted (see Fig. 5, bottom right).

For the electrical connection a 10 meter connecting lead with M12x1 connectors is included in the scope of delivery.

pneumatic and electrical connection.

Operation and setting are described in sections 7 and 8.

- *Since 2009, the back of the position sensor (20) is fitted with two pins acting as mechanical stops for the lever (1). If this position sensor is mounted using old mounting parts, two corresponding $\varnothing 8$ mm holes must be drilled into the mounting plate/bracket (21). A template is available for this purpose. See Table 7.*



Note:

- *In addition, the instructions in sections 5.1 and 5.2 apply for the*

4.7.1 Mounting the position sensor with direct attachment

Type 3277-5 Actuator with 120 cm² (Fig. 15)

The signal pressure from the positioner is routed over the signal pressure connection of the connecting plate (9, Fig. 15 left) to the actuator diaphragm chamber. To proceed, first screw the connecting plate (9) included in the accessories onto the actuator yoke.

- Turn the connecting plate (9) so that the correct symbol for the fail-safe action "actuator stem extends" or "actuator stem

retracts" is aligned with the marking (Fig. 15, below).

- Make absolutely sure that the gasket for the connecting plate (9) is correctly inserted.
- The connecting plate has threaded holes with NPT and G threads. Seal the threaded connection that is not used with the rubber seal and square plug.

Type 3277 Actuator with 175 to 750 cm²:

The signal pressure is routed to the connection at the side of the actuator yoke for the version with "actuator stem extends" fail-safe

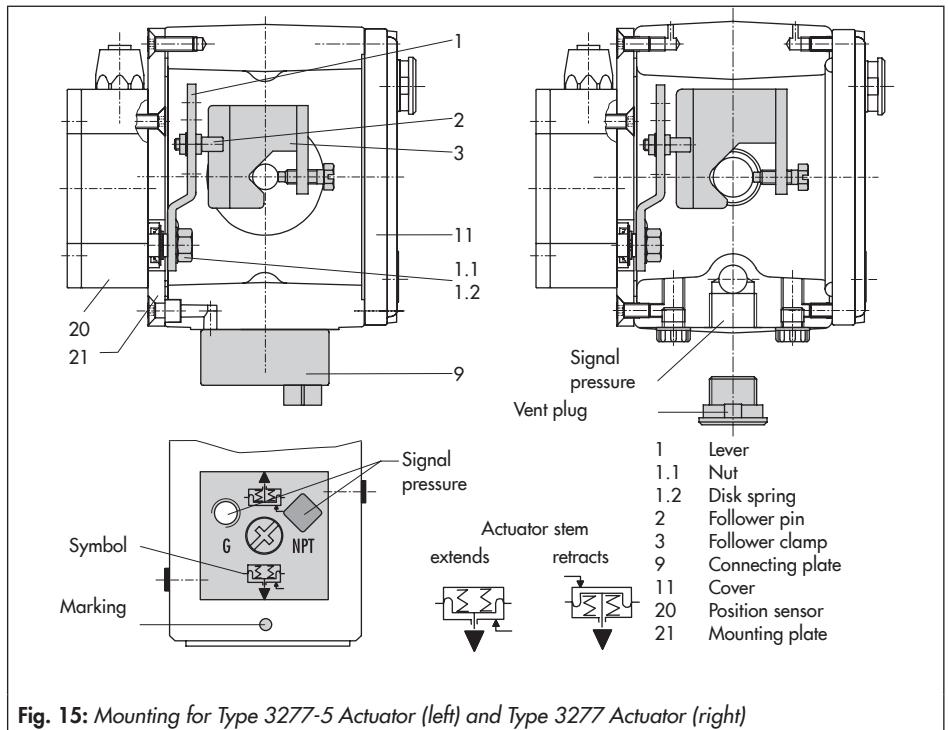

action. For the fail-safe action "actuator stem retracts" the connection on the top diaphragm case is used. The connection at the side of the yoke must be fitted with a venting plug (accessories).

Mounting the position sensor

1. Place the lever (1) on the sensor in mid-position and hold it in place. Unthread the nut (1.1) and remove the lever together with the disk spring (1.2) from the sensor shaft.
2. Screw the position sensor (20) onto the mounting plate (21).
3. Depending on the actuator size and rated valve travel, determine which lever and position of the follower pin (2) is to be used from the travel table on page 21. The positioner is delivered with the **M** lever in pin position **35** on the sensor. If necessary, remove the follower pin (2) from its pin position and move it to the hole for the recommended pin position and screw tight.
4. Place the lever (1) and disk spring (1.2) on the sensor shaft. Place the lever in **mid-position** and **hold it in place**. Screw on the nut (1.1).
5. Place follower clamp (3) on the actuator stem, align it and screw tight so that the mounting screw is located in the groove of the actuator stem.
6. Place the mounting plate together with the sensor onto the actuator yoke so that the follower pin (2) rests on the top of the follower clamp (3). It must rest on it with spring force. Fasten the mounting plate

(21) onto the actuator yoke using both fixing screws.

7. Mount cover (11) on the other side. Make sure that the vent plug is located at the bottom when the control valve is installed to allow any condensed water that collects to drain off.

4.7.2 Mounting the position sensor with attachment according to IEC 60534-6

- Required mounting parts and accessories: Table 7 on page 54

Fig. 16

1. Place the lever (1) on the position sensor in **mid-position** and **hold it in place**. Unthread the nut (1.1) and remove the lever together with the disk spring (1.2) from the sensor shaft.
2. Screw the position sensor (20) onto the bracket (21).

The standard attached **M** lever with the follower pin (2) at position **35** is designed for

120 to 350 cm² actuators with 15 mm rated travel. For other actuator sizes or travels, select the lever and pin position from the travel table on page 21. **L** and **XL** levers are included in the mounting kit.

3. Place the lever (1) and disk spring (1.2) on the sensor shaft. Place the lever in **mid-position** and **hold it in place**. Screw on the nut (1.1).
4. Screw the two bolts (14) to the bracket (9.1) of the stem connector (9), place the follower plate (3) on top and use the screws (14.1) for fastening.
5. Place the bracket with the sensor at the NAMUR rib in such a manner that the follower pin (2) rests in the slot of the follower plate (3), then screw the bracket using its fixing screws onto the valve.

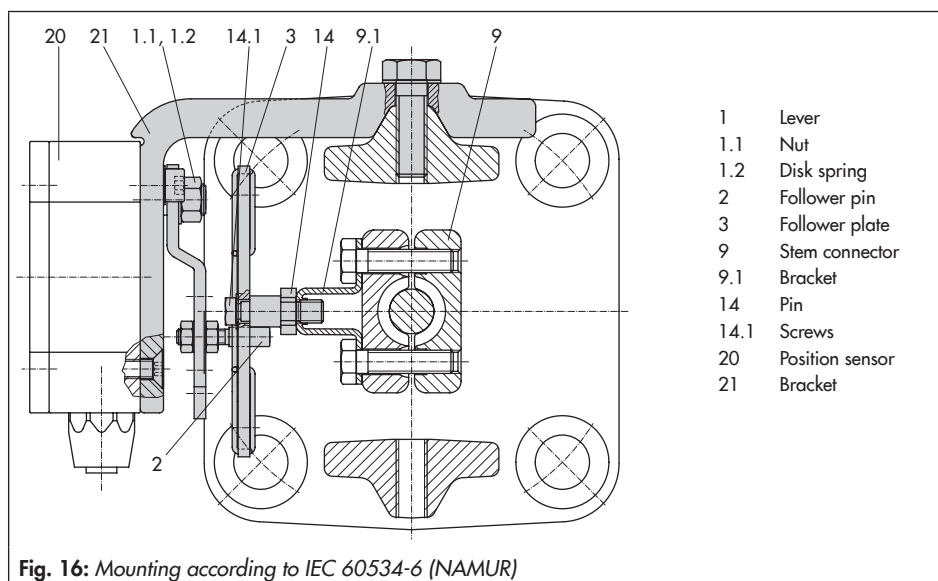

4.7.3 Mounting the position sensor to Type 3510 Micro-flow Valve

– Required mounting parts and accessories: Table 7 on page 54

Fig. 17

1. Place the lever (1) on the position sensor in **mid-position** and **hold it in place**. Unscrew the nut (1.1) and remove the standard attached **M** lever (1) together with the disk spring (1.2) from the sensor shaft.
2. Screw the position sensor (20) onto the bracket (21).
3. Select the **S** lever (1) from the accessories and screw the follower pin (2) into the

hole for pin position **17**. Place the lever (1) and disk spring (1.2) on the sensor shaft. Place the lever in mid-position and hold it in place. Screw on the nut (1.1).

4. Place follower clamp (3) on the valve stem connector, align at a right angle and screw tight.
5. Position the bracket (21) with the position sensor on the valve yoke and screw tight, making sure the follower pin (2) slides into the groove of the follower clamp (3).

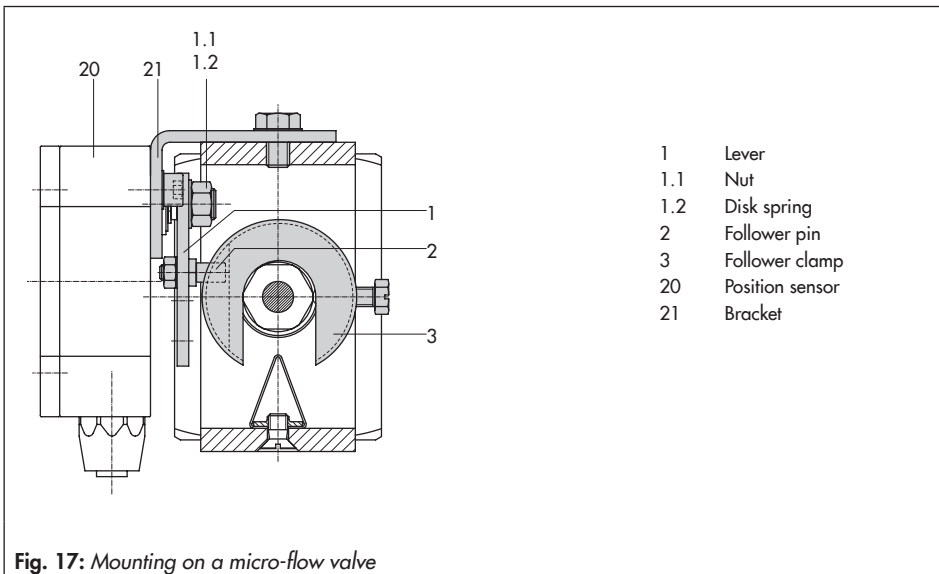

4.7.4 Mounting on rotary actuators

- Required mounting parts and accessories: Table 7 on page 54

Fig. 18

1. Place the lever (1) on the position sensor in **mid-position** and **hold it in place**. Unthread the nut (1.1) and remove the lever together with the disk spring (1.2) from the sensor shaft.
2. Screw the position sensor (20) onto the mounting plate (21).
3. Replace the follower pin (2) normally attached to the lever (1) with the metal follower pin (\varnothing 5 mm) from the accessories and screw it into the hole for pin position 90°.

4. Place the lever (1) and disk spring (1.2) on the sensor shaft. Place the lever in **mid-position** and **hold it in place**. Screw on the nut (1.1).

Follow the instructions describing attachment to the standard positioner in section 4.5.

Instead of the positioner, attach the position sensor (20) with its mounting plate (21).

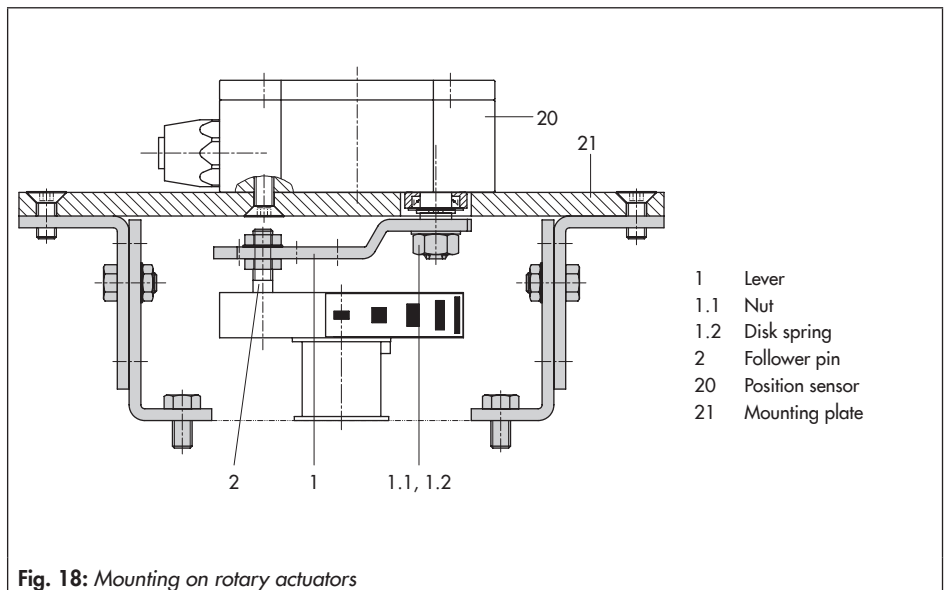

Fig. 18: Mounting on rotary actuators

4.8 Mounting the leakage sensor

Fig. 19

Normally, the control valve is delivered with positioner and leakage sensor already mounted.

If the leakage sensor is mounted after the valve has been installed or it is mounted on to another control valve, proceed as described in following.



NOTICE

Risk of malfunction due to incorrect fastening!

Fasten the leakage sensor using a torque of 20 ± 5 Nm.

The M8 threaded connection on the NAMUR rib should preferably be used to mount the sensor (Fig. 19).



Tip:

If the positioner was mounted directly onto the actuator (integral attachment), the NAMUR interfaces on either side of the valve yoke can be used to mount the leakage sensor.

The start-up of the leakage sensor is described in detail in the Operating Instructions for EXPERTplus Valve Diagnostics

▶ EB 8389.

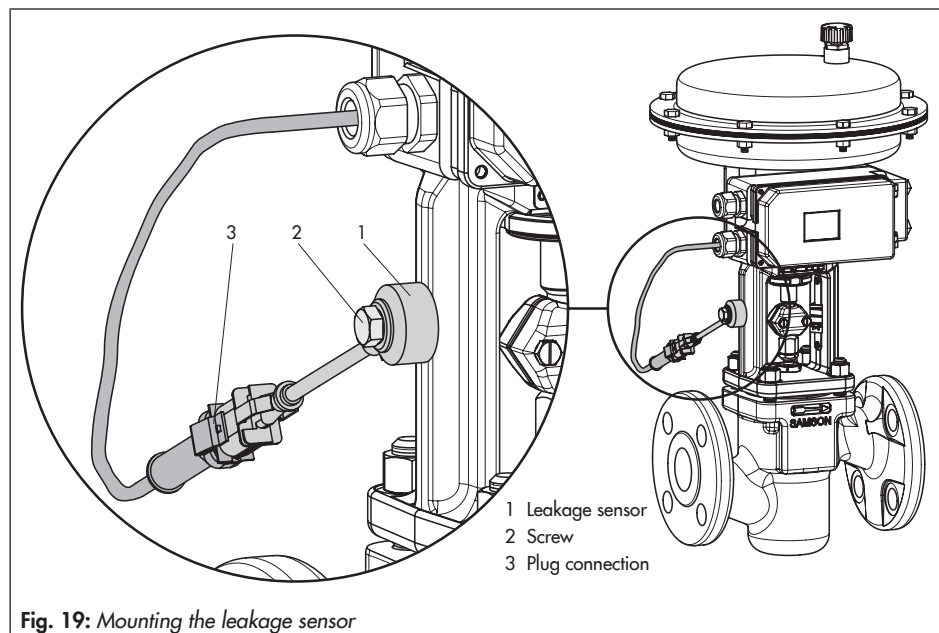

Fig. 19: Mounting the leakage sensor

4.9 Attaching positioners with stainless steel housings

Positioners with stainless steel housings require mounting parts that are completely made of stainless steel or free of aluminum.



Note:

The pneumatic connecting plate and pressure gauge bracket are available in stainless steel (order numbers listed below). The Type 3710 Pneumatic Reversing Amplifier is also available in stainless steel.

Connecting plate (stainless steel)	G ¼ ¼ NPT	1400-7476 1400-7477
Pressure gauge bracket (stainless steel)	G ¼ ¼ NPT	1402-0265 1400-7108

Table 1 to Table 6 apply for attaching positioners with stainless steel housings with the following restrictions:

Direct attachment

All mounting kits from Table 1 and Table 2 can be used. The connection block is not required. The stainless steel version of the pneumatic connecting plate routes the air internally to the actuator.

Attachment according to IEC 60534-6 (NAMUR rib or attachment to rod-type yokes)

All mounting kits from Table 3 can be used. Connecting plate in stainless steel.

Attachment to rotary actuators

All mounting kits from Table 5 can be used except for the heavy-duty version. Connecting plate in stainless steel.

4.10 Air purging function for single-acting actuators

The instrument air leaving from the positioner is diverted to the actuator spring chamber to provide corrosion protection inside the actuator. The following must be observed:

Direct attachment to Type 3277-5 (stem extends FA/stem retracts FE)

The air purging function is automatically provided.

Direct attachment to Type 3277, 175 to 750 cm²

FA: Remove the stopper (12.2, Fig. 4) at the black connection block and make a pneumatic connection to the spring chamber on the vented side.



NOTICE

Mounting possibly incorrect when old powder-paint-coated aluminum connection blocks are used.

Mount old powder-paint-coated aluminum connection blocks as described in sections on „Attachment according to IEC 60534-6 (NAMUR rib or attachment to rod-type yokes)“ and „Attachment to rotary actuators“.

FE: The air purging function is automatically provided.

Attachment according to IEC 60534-6 (NAMUR rib or attachment to rod-type yokes) and to rotary actuators

The positioner requires an additional port for the exhaust air that can be connected over piping. An adapter available as an accessory is used for this purpose:

Threaded bushing (M20 x 1.5)	G ¼ ¼ NPT	0310-2619 0310-2550
------------------------------	--------------	------------------------

Should other valve accessories be used which vent the actuator (e.g. solenoid valve, volume booster, quick exhaust valve), this exhaust air must also be included in the purging function. The connection over the adapter at the positioner must be protected with a check valve (e.g. check valve G ¼, order no. 8502-0597) mounted in the piping. Otherwise the pressure in the positioner housing would rise above the ambient pressure and damage the positioner when the exhausting components respond suddenly.



Note:

The adapter uses one of the M20 x 1.5 connections in the housing which means **only one** cable gland can be installed.

4.11 Required mounting parts and accessories

Table 1: Direct attachment to Type 3277-5 Actuator (Fig. 3)		Order no.	
Mounting parts	Standard version for actuators 120 cm ² or smaller	1400-7452	
	Version compatible with paint for actuators 120 cm ² or smaller	1402-0940	
Accessories for actuator	Old switchover plate for Type 3277-5xxxxxx. 00 Actuator (old)	1400-6819	
	New switchover plate for Type 3277-5xxxxxx. 01 Actuator (new) ¹⁾	1400-6822	
	New connecting plate for Type 3277-5xxxxxx. 01 Actuator (new) ¹⁾ , G ½ and ½ NPT	1400-6823	
	Old connecting plate for Type 3277-5xxxxxx. 00 Actuator (old): G ½	1400-6820	
	Old connecting plate for Type 3277-5xxxxxx. 00 (old): ½ NPT	1400-6821	
Accessories for positioner	Connecting plate (6)	G ¼	1400-7461
		¼ NPT	1400-7462
	Pressure gauge bracket (7)	G ¼	1400-7458
		¼ NPT	1400-7459
	Pressure gauge mounting kit (8) up to max. 6 bar (output/supply)	St. steel/brass	1400-6950
St. steel/st. steel		1400-6951	

¹⁾ Only new switchover and connecting plates can be used with new actuators (Index 01). Old and new plates are not interchangeable.

Table 2: Direct attachment to Type 3277 Actuator (Fig. 4)			Order no.		
Mounting parts	Standard version for actuators 175, 240, 350, 355, 700, 750 cm ²		1400-7453		
	Version compatible with paint for actuators 175, 240, 350, 355, 700, 750 cm ²		1402-0941		
Accessories	Piping with screw fittings – for "actuator stem retracts" fail-safe action – with air purging of the top diaphragm chamber	175 cm ²	Steel G 1/4 / G 3/8	1402-0970	
			1/4 NPT / 3/8 NPT	1402-0976	
		St. steel	G 1/4 / G 3/8	1402-0971	
			1/4 NPT / 3/8 NPT	1402-0978	
		240 cm ²	Steel	G 1/4 / G 3/8	1400-6444
			1/4 NPT / 3/8 NPT	1402-0911	
		St. steel	G 1/4 / G 3/8	1400-6445	
			1/4 NPT / 3/8 NPT	1402-0912	
		350 cm ²	Steel	G 1/4 / G 3/8	1400-6446
			1/4 NPT / 3/8 NPT	1402-0913	
		St. steel	G 1/4 / G 3/8	1400-6447	
			1/4 NPT / 3/8 NPT	1402-0914	
		355 cm ²	Steel	G 1/4 / G 3/8	1402-0972
			1/4 NPT / 3/8 NPT	1402-0979	
		St. steel	G 1/4 / G 3/8	1402-0973	
			1/4 NPT / 3/8 NPT	1402-0980	
		700 cm ²	Steel	G 1/4 / G 3/8	1400-6448
			1/4 NPT / 3/8 NPT	1402-0915	
		St. steel	G 1/4 / G 3/8	1400-6449	
			1/4 NPT / 3/8 NPT	1402-0916	
		750 cm ²	Steel	G 1/4 / G 3/8	1402-0974
			1/4 NPT / 3/8 NPT	1402-0981	
		St. steel	G 1/4 / G 3/8	1402-0975	
			1/4 NPT / 3/8 NPT	1402-0982	
Connection block with seals and screw		G 1/4	1400-8819		
		1/4 NPT	1402-0901		
Pressure gauge mounting kit up to max. 6 bar (output/supply)		Stainless steel/brass	1400-6950		
		St. steel/st. steel	1400-6951		

Attachment to the control valve – Mounting parts and accessories

Table 3: Attachment to NAMUR ribs or control valves with rod-type yokes (20 to 35 mm rod diameter) according to IEC 60534-6 (Fig. 5 and Fig. 9)

Travel in mm	Lever	For actuator	Order no.
7.5	S	Type 3271-5 with 60/120 cm ² on Type 3510 Micro-flow Valve (Fig. 9)	1402-0478
5 to 50	M ¹⁾	Actuators from other manufacturers and Type 3271 with 120 to 750 cm ² effective areas	1400-7454
14 to 100	L	Actuators from other manufacturers and Type 3271 with 1000 and 1400-60 cm ²	1400-7455
40 to 200	XL	Actuators from other manufacturers and Type 3271 with 1400-120 and 2800 cm ² and with 120 mm travel	1400-7456
30 or 60	L	Type 3271 with 1400-120 and 2800 cm ² with 30/60 mm travel ²⁾	1400-7466
		Mounting brackets for Emerson and Masoneilan linear actuators (in addition, a mounting kit according to IEC 60534-6 is required depending on the travel). See rows above.	1400-6771
		Valtek Type 25/50	1400-9554
Accessories	Connecting plate (6)	G ¼	1400-7461
		¼ NPT	1400-7462
	Pressure gauge bracket (7)	G ¼	1400-7458
		¼ NPT	1400-7459
	Pressure gauge mounting kit up to max. 6 bar (output/supply)	Stainless steel/brass	1400-6950
		St. steel/st. steel	1400-6951

¹⁾ M lever is mounted on basic device (included in the scope of delivery)

²⁾ In conjunction with Type 3273 Side-mounted Handwheel with 120 mm rated travel, additionally one bracket (0300-1162) and two countersunk screws (8330-0919) are required.

Table 4: Attachment according to VDI/VDE 3847 (Fig. 6 and Fig. 8)

Electropneumatic positioners with VDI/VDE 3847 interface (Type 3730-3xxx0xxxx0x0070xx)		Order no.
Mounting parts	Interface adapter	1402-0257
	Mounting kit for attachment to SAMSON Type 3277 Actuator with 175 to 750 cm ²	1402-0868
	Mounting kit for attachment to SAMSON Type 3271 Actuator or non-SAMSON actuators	1402-0869
	Travel pick-off for valve travel up to 100 mm	1402-0177
	Travel pick-off for 100 to 200 mm valve travel (SAMSON Type 3271 Actuator only)	1402-0178

Table 5: Attachment to rotary actuators (Fig. 10 and Fig. 11)			Order no.
Mounting parts	Attachment acc. to VDI/VDE 3845 (September 2010), see section 15.1 for details		
	Actuator surface corresponds to fixing level 1		
	Size AA1 to AA4, version with CrNiMo steel bracket		1400-7448
	Size AA1 to AA4, heavy-duty version		1400-9244
	Size AA5, heavy-duty version (e.g. Air Torque 10 000)		1400-9542
	Bracket surface corresponds to fixing level 2, heavy-duty version		1400-9526
	Attachment for rotary actuators with max. 180° opening angle, fixing level 2		1400-8815 and 1400-9837
	Attachment to SAMSON Type 3278 with 160/320 cm ² , CrNiMo steel bracket		1400-7614
	Attachment to SAMSON Type 3278 with 160 cm ² and to VETEC Type S160, Type R and Type M, heavy-duty version		1400-9245
	Attachment to SAMSON Type 3278 with 320 cm ² and to VETEC Type S320, heavy-duty version		1400-5891 and 1400-9526
Attachment to Camflex II		1400-9120	
Accessories	Connecting plate (6)	G ¼	1400-7461
		¼ NPT	1400-7462
	Pressure gauge bracket (7)	G ¼	1400-7458
		¼ NPT	1400-7459
	Pressure gauge mounting kit up to max. 6 bar (output/supply)	St. steel/brass	1400-6950
		St. steel/brass	1400-6951

Table 6: General accessories			Order no.
Reversing amplifier for double-acting actuators			Type 3710
Cable gland M20 x 1.5,	Black plastic (6 to 12 mm clamping range)		8808-1011
	Blue plastic (6 to 12 mm clamping range)		8808-1012
	Nickel-plated brass (6 to 12 mm clamping range)		1890-4875
	Nickel-plated brass (10 to 14 mm clamping range)		1922-8395
	Stainless steel 1.4305 (8 to 14.5 mm clamping range)		8808-0160
Adapter M20x1.5 to ½ NPT	Powder-coated aluminum		0310-2149
	Stainless steel		1400-7114
Retrofit kit for inductive limit switch 1 x SJ2-SN			1400-7460
Cover plate with list of parameters and operating instructions	DE/EN (delivered state)		1990-0761
	EN/ES		1990-3100
	EN/FR		1990-3142
TROVIS-VIEW 6661 with Type 3730-3 device module			

Attachment to the control valve – Mounting parts and accessories

Table 6: General accessories	Order no.
Serial interface adapter (SAMSON SSP interface to RS-232 port on a PC)	1400-7700
Isolated USB interface adapter (SAMSON SSP interface to USB port on a PC) including TROVIS-VIEW CD-ROM	1400-9740

Table 7: Attachment of external position sensor	Order no.		
Template for mounting position sensor on older mounting parts. See note on page 42	1060-0784		
Direct attachment	Mounting parts for actuators with 120 cm ² . See Fig. 15 (left).	1400-7472	
	Connecting plate (9, old) with Type 3277-5xxxxxx.00 Actuator	G 1/8	1400-6820
		1/8 NPT	1400-6821
	Connecting plate (new) with Type 3277-5xxxxxx.01 Actuator (new) ¹⁾	1400-6823	
	Mounting parts for actuators with 175, 240, 350, 355 and 700 cm ² . See Fig. 15 (right).	1400-7471	
NAMUR attachment	Mounting parts for attachment to NAMUR rib using L or XL lever. See Fig. 16.	1400-7468	
Attachment to Type 3510 Micro-flow Valve	Mounting parts for Type 3271 Actuator with 60 cm ² . See Fig. 17.	1400-7469	
Attachment to rotary actuators	VDI/VDE 3845 (September 2010), see section 15.1 for details.		
	Actuator surface corresponds to fixing level 1		
	Size AA1 to AA4 with follower clamp and coupling wheel, version with CrNiMo steel bracket. See Fig. 18.	1400-7473	
	Size AA1 to AA4, heavy-duty version	1400-9384	
	Size AA5, heavy-duty version (e.g. Air Torque 10 000)	1400-9992	
	Bracket surface corresponds to fixing level 2, heavy-duty version	1400-9974	
	SAMSON Type 3278 with 160 cm ² and VETEC Type S160 and Type R, heavy-duty version	1400-9385	
	SAMSON Type 3278 with 320 cm ² and VETEC Type S320, heavy-duty version	1400-5891 and 1400-9974	
Accessories for positioner	Connecting plate (6)	G 1/4	1400-7461
		1/4 NPT	1400-7462
	Pressure gauge bracket (7)	G 1/4	1400-7458
		1/4 NPT	1400-7459
	Pressure gauge mounting kit up to max. 6 bar (output/supply)	Stainless steel/brass	1400-6950
		Stainless steel/stainless steel	1400-6951
	Bracket to mount the positioner on a wall (Note: The other fastening parts are to be provided at the site of installation as wall foundations vary from site to site).	0309-0184	

¹⁾ Only new connecting plates can be used with new actuators (Index 01). Old and new plates are not interchangeable.

5 Connections



WARNING!

Risk of injury due to the actuator stem extending or retracting. Do not touch or block the actuator stem.



NOTICE

Risk of malfunction due to incorrect sequence of mounting, installation and start-up. Keep the following sequence.

1. Remove the protective film from the pneumatic connections.
2. Mount the positioner on the control valve.
3. Connect the supply air.
4. Connect the electrical power.
5. Perform the start-up settings.

5.1 Pneumatic connections



NOTICE

Malfunction due to incorrect connection of the supply air.

Do not connect the compressed air directly to the threaded connections in the positioner housing. Screw the screw fittings into the connecting plate, pressure gauge mounting block or connection block from the accessories.

The pneumatic connections in the connecting plate, pressure gauge mounting block and connection block are optionally designed as

a bore with $\frac{1}{4}$ NPT or G $\frac{1}{4}$ thread. Customary fittings for metal or copper tubing or plastic hoses can be used.



NOTICE

Risk of malfunction due to failure to comply with required air quality. Only use supply air that is dry and free of oil and dust.

Read the maintenance instructions for upstream pressure reducing stations. Blow through all air pipes and hoses thoroughly before connecting them.

If the positioner is attached directly to the Type 3277 Actuator, the connection of the positioner's output pressure to the actuator is fixed. For attachment according to IEC 60534-6 (NAMUR), the signal pressure can be routed to either the top or bottom diaphragm chamber of the actuator, depending on the actuator's fail-safe action "actuator stem extends" or "actuator stem retracts".

For rotary actuators, the manufacturer's specifications for connection apply.

5.1.1 Signal pressure gauges

To monitor the supply air (supply) and signal pressure (output), we recommend mounting pressure gauges.

5.1.2 Supply pressure

The required supply air pressure depends on the bench range and the actuator's operating direction (fail-safe action).

The bench range is written on the nameplate either as the spring range or signal pressure range depending on the actuator. The direction of action is marked **FA** or **FE**, or by a symbol.

Actuator stem extends FA (AIR TO OPEN)

Fail-close (for globe and angle valves):

Required supply pressure = Upper bench range value + 0.2 bar, at least 1.4 bar.

Actuator stem retracts FE (AIR TO CLOSE)

Fail-open (for globe and angle valves):

For tight-closing valves, the maximum signal pressure p_{stmax} is roughly estimated as follows:

$$p_{stmax} = F + \frac{d^2 \cdot \pi \cdot \Delta p}{4 \cdot A} \quad [\text{bar}]$$

d = Seat diameter [cm]

Δp = Differential pressure across the valve [bar]

A = Actuator diaphragm area [cm²]

F = Upper bench range value of the actuator [bar]

If there are no specifications, calculate as follows:

Required supply pressure = Upper bench range value + 1 bar

5.1.3 Signal pressure (output)

The signal pressure at the output (38) of the positioner can be restricted to 1.4 bar, 2.4 bar or 3.7 bar in Code 16.

The limitation is not activated [No] by default.

5.2 Electrical connections



DANGER!

Risk of electric shock and/or the formation of an explosive atmosphere.

For electrical installation, observe the relevant electrotechnical regulations and the accident prevention regulations that apply in the country of use. In Germany, these are the VDE regulations and the accident prevention regulations of the employers' liability insurance.

The following regulations apply to installation in hazardous areas:

EN 60079-14: 2008 (VDE 0165,

Part 1) **Explosive Atmospheres – Electrical Installations Design, Selection and Erection.**



WARNING!

Incorrect electrical connection will render the explosion protection unsafe.

Adhere to the terminal assignment.

Do not undo the enameled screws in or on the housing.

Do not exceed the maximum permissible values specified in the EC type examination certificates when interconnecting intrinsically safe electrical equipment (U_i or U_o , I_i or I_o , P_i or P_o , C_i or C_o and L_i or L_o).

Selecting cables and wires

Observe **clause 12 of EN 60079-14: 2008** (VDE 0165, Part 1) for installation of the intrinsically safe circuits.

Clause 12.2.2.7 applies when running multi-core cables and wires with more than one intrinsically safe circuit.

The radial thickness of the insulation of a conductor for common insulating materials (e.g. polyethylene) must not be smaller than 0.2 mm. The diameter of an individual wire in a fine-stranded conductor must not be smaller than 0.1 mm. Protect the conductor ends against splicing, e.g. by using wire-end ferrules. When two separate cables or wires are used for connection, an additional cable gland can be installed. Seal cable entries left unused with plugs. Fit equipment used in ambient temperatures **below -20 °C** with metal cable entries.

Equipment for use in zone 2/zone 22

In equipment operated according to type of protection Ex nA II (non-sparking equipment) according to EN 60079-15:2003, circuits may be connected, interrupted or switched while energized only during installation, maintenance or repair.

Equipment connected to energy-limited circuits with type of protection Ex nL (energy-limited equipment) according to EN 60079-15: 2003 may be switched under normal operating conditions.

The maximum permissible values specified in the statement of conformity and its addenda apply when interconnecting the equipment with energy-limited circuits in type of protection Ex nL IIC.

Cable entry

Cable entry with M20 x 1.5 cable gland, 6 to 12 mm clamping range.

There is a second M20 x 1.5 threaded hole in the housing that can be used for additional connection, when required.

The screw terminals are designed for wire cross-sections of 0.2 to 2.5 mm² (tightening torque of screws 0.5 to 0.6 Nm).

The wires for the set point must be connected to the terminals 11 and 12 located in the housing.

Only use a **current source**. **OVERLOAD** appears on the display when the set point exceeds 22 mA.

! NOTICE

The connection of a voltage source ($U \geq 7 \text{ V}$ or $U \geq 2 \text{ V}$ when connected to the wrong pole) can damage the positioner.

Only use a current source and never a voltage source!

In general, it is not necessary to connect the positioner to a bonding conductor. Should this be required, however, this conductor can be connected inside the device.

Depending on the version, the positioner is equipped with inductive limit switches and/or a solenoid valve.

The position transmitter is operated on a two-wire circuit.

The usual supply voltage is 24 V DC. Taking the resistance of the supply leads into account, the voltage at the position transmitter

terminals can be between at least 12 and 30 V DC at the maximum.

Refer to Fig. 20 or to the label on the terminal block.

NOTICE
 Malfunction due the current falling below minimum current.
 Do not allow the set point to fall below 3.8 mA.

Accessories

Cable glands M20 x 1.5	Order no.
Black plastic (6 to 12 mm clamping range)	8808-1011
Blue plastic (6 to 12 mm clamping range)	8808-1012
Nickel-plated brass (6 to 12 mm clamping range)	1890-4875
Nickel-plated brass (10 to 14 mm clamping range)	1922-8395
Stainless steel 1.4305 (8 to 14.5 mm clamping range)	8808-0160

Adapter M20 x 1.5 to ½ NPT	Order no.
Powder-coated aluminum	0310-2149
Stainless steel	1400-7114

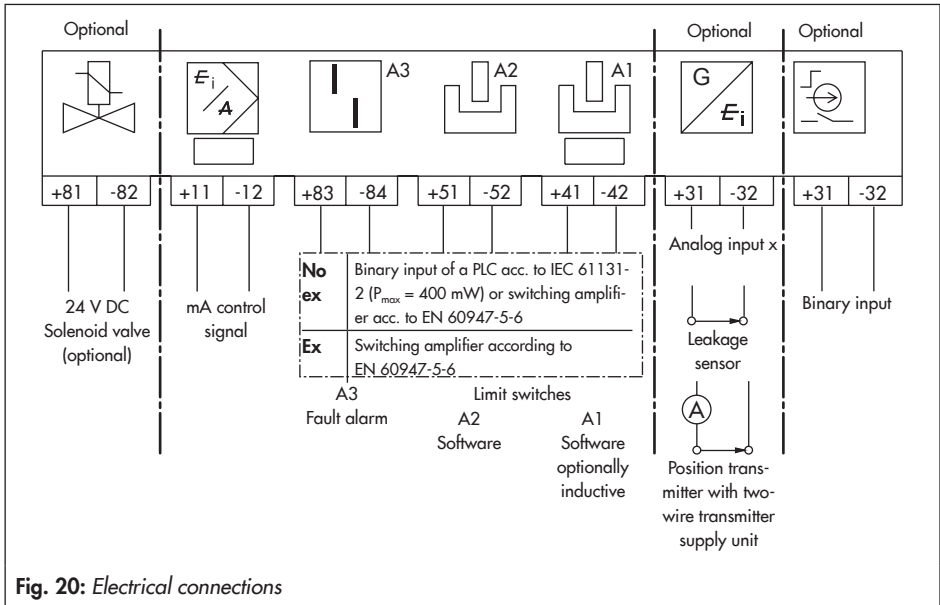

**Note:**

In positioners for attachment according to VDI/VDE 3847, the terminal designation of the limit switches 41/42 and 51/52 as well as the OPEN and CLOSED wording can be changed by turning the terminal label which is printed on both sides.

5.2.1 Switching amplifier

For operation of the limit switches, switching amplifiers must be connected in the output circuit. To ensure the operating reliability of the positioner, the amplifiers should comply with the limit values of the output circuits conforming to EN 60947-5-6.

Observe the relevant regulations for installation in hazardous areas.

For applications in safe areas (non-hazardous areas), limit switches can be directly interconnected to the binary input of the PLC in accordance with IEC 61131. This applies to the standard operating range for digital inputs according to Clause 5.2.1.2 of IEC 61131-2 with the rated voltage of 24 V DC.

5.2.1 Establishing communication

Communication between computer and positioner using an FSK modem or handheld communicator (if necessary, using an isolation amplifier) is based on the HART® protocol.

Viator FSK modem

– RS-232 No ex Order no. 8812-0130

– PCMCIA No ex Order no. 8812-0131

– USB No ex Order no. 8812-0132

If the load impedance of the controller or control station is too low, an isolation amplifier must be connected between controller and positioner (interfacing as for positioner Fig. 22 connected in hazardous areas).

If the positioner is used in hazardous areas, an explosion-protected isolation amplifier must be used.

Using the HART® protocol, all connected control room and field units can be addressed individually using a point-to-point connection or the standard (multidrop) bus.

Point-to-point:

The bus address/polling address must always be set to zero (0).

Standard bus (multidrop):

In the standard bus (multidrop) mode, the positioner follows the analog current signal (set point) in the same manner as for point-to-point communication. This operating

mode is, for example, suitable for split-range operation of positioners (series connection). The bus address/polling address has to be within a range of 1 to 15.



Note:

Communication errors may occur when the process controller/control station output is not HART®-compatible.

For adaptation, the Z box (order no. 1170-2374) can be installed between output and communication interface. At the Z box a voltage of approx. 330 mV is released (corresponds to 16.5 Ω at 20 mA).

Alternatively, a 250 Ω resistor can be connected in series and a 22 μF capacitor can be connected in parallel to the analog output. The load for the controller output will increase as a result.

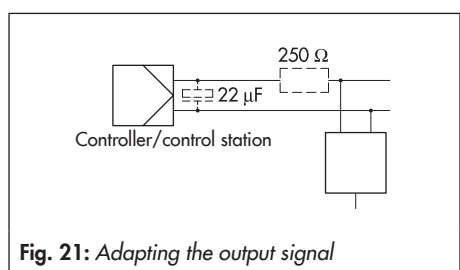

Fig. 21: Adapting the output signal

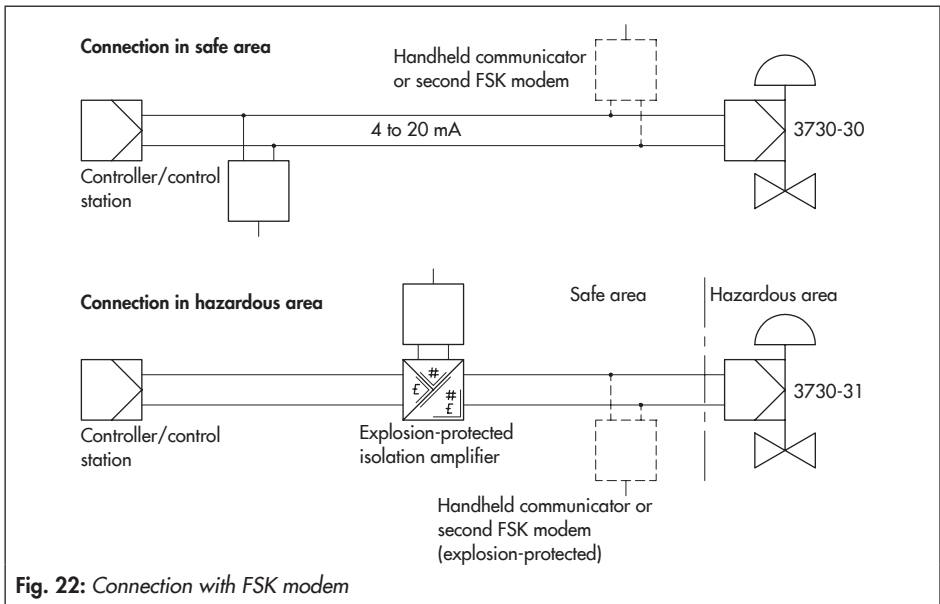

Fig. 22: Connection with FSK modem

6 Operating controls and readings

⊗ Rotary pushbutton

The rotary pushbutton is located underneath the front protective cover. The positioner is operated on site using the rotary pushbutton:

Turn ⊗: Select codes and values

Press ⊗: Confirm setting

AIR TO OPEN/AIR TO CLOSE slide switch

- AIR TO OPEN applies to a valve opening as the signal pressure increases.
- AIR TO CLOSE applies to a valve closing as the signal pressure increases.

The signal pressure is the pneumatic pressure at the output of the positioner applied to the actuator.

Volume restriction Q

The volume restriction serves to adapt the air output capacity to the size of the actuator. Depending on the air passage at the actuator, two fixed settings are available.

- For actuators smaller than 240 cm² and with a signal pressure connection at the side (Type 3271-5), set restriction to MIN SIDE.
- For a connection at the back (Type 3277-5), set restriction to MIN BACK.
- For actuators 240 cm² and larger, set to MAX SIDE for a side connection and to MAX BACK for a connection at the back.

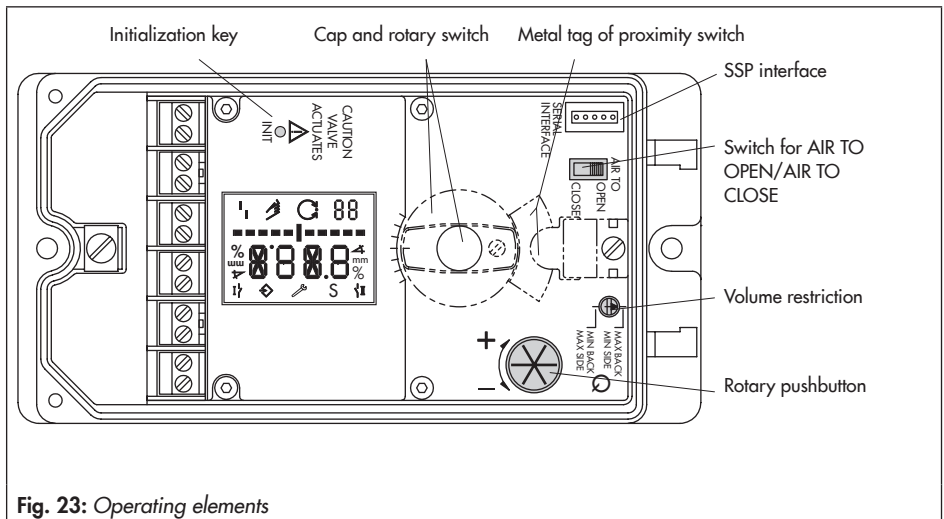
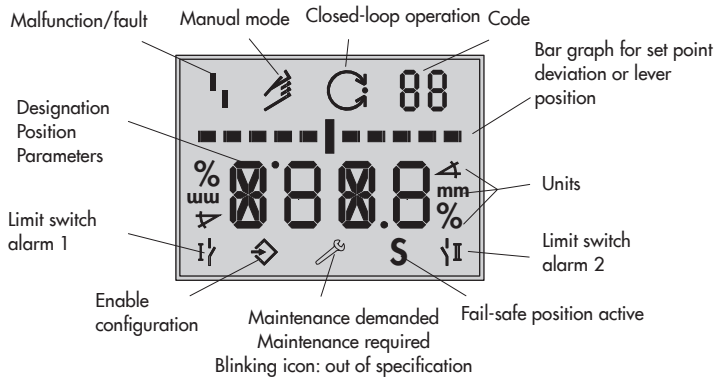

Fig. 23: Operating elements





AUTO	Automatic	TunE	Initialization in progress
Class	Clockwise	YES	Available/active
CCL	Counterclockwise	ZP	Zero calibration
Err	Error	↗↗	Increasing/increasing
ESC	Cancel	↗↘	Increasing/decreasing
HI	ix higher than 21.6 mA	⊙ blinks	Emergency mode (see error code 62)
LO	ix lower than 2.4 mA	↗ blinks	Initialization missing
LOW	w too low	S	Valve in mechanical fail-safe position
MAN	Manual setting		
MAX	Maximum range		
No	Not available/not active		
NOM	Rated travel		
OVERLOAD	x > 22 mA		
RES	Reset		
RUN	Start		
SAFE	Fail-safe position		
Sub	Substitute calibration		
tESinG	Test function active		

Fig. 24: Display



Readings

Icons assigned to certain codes, parameters and functions are indicated on the display.

Operating modes:



-  **(manual mode)**
The positioner follows the manual set point (Code 1) instead of the mA signal.
 blinks: The positioner is not initialized. Operation only possible over manual set point (Code 1).
-  **(automatic mode)**
The positioner is in closed-loop operation and follows the mA signal.
- **S SAFE**
The positioner vents the output. The valve moves to the mechanical fail-safe position.

Bar graph:

In manual  and automatic  modes, the bars indicate the set point deviation that depends on the sign (+/-) and the value. One bar element appears per 1 % set point deviation.

If the positioner has not been initialized, ( blinks on the display), the bar graph indicates the lever position in degrees in relation to the mid-axis. One bar element corresponds to approximately a 5° angle of rotation. The fifth bar element blinks (reading > 30°) if the permissible angle of rotation has been exceeded. Lever and pin position must be checked.

Status messages

-  Maintenance alarm
-  Maintenance demanded/
Maintenance required
-  blinks: Out of specification

These icons indicate that an error has occurred.

A classified status can be assigned to each error. Classifications include “No message”, “Maintenance required”, “Maintenance demanded” and “Maintenance alarm” (see ► EB 8389 on EXPERTplus valve diagnostics).

Enable configuration

This indicates that the codes marked with an asterisk (*) in the code list are enabled for configuration (see section 14).

6.1 Serial interface

The positioner must be supplied with at least 4 mA.

The positioner can be connected directly to the computer over the local serial interface and the serial interface adapter.

The operator software is TROVIS-VIEW with installed device module 3730-3.

6.2 HART® communication

The positioner must be supplied with at least 4 mA. The FSK modem must be connected in parallel to the current loop.

A DTM file (Device Type Manager) conforming to the Specification 1.2 is available for communication. This allows the device, for

example, to be run with the PACTware operator interface.

All the positioner's parameters are accessible over the DTM and the user interface.

For start-up and settings, proceed as described in section 7.1 to section 7.4. Refer to the code list in section 1.4 for the parameters necessary for the operator interface.



Note:

If complex functions are started in the positioner, which require a long calculation time or lead to a large quantity of data being saved in the volatile memory of the positioner, the alert 'busy' is issued by the DTM file.

This alert is not an error message and can be simply confirmed.

6.2.1 Dynamic HART® variables

The HART® specification defines four dynamic variables consisting of a value and an engineering unit. These variables can be assigned to device parameters as required. The universal HART® command 3 reads the dynamic variables out of the device. This allows manufacturer-specific parameters to also be transferred using a universal command.

In the Type 3730-3 Positioner, the dynamic variables can be assigned by the DD or in TROVIS-VIEW [Settings > Operation unit] as shown in Table 8.

Locking HART® communication

The write access for HART® communication can be disabled over Code 47. This function can only be enabled or disabled locally at the positioner.

Write access is enabled by default.

Locking on-site operation

The on-site operation including the INIT key can be locked over HART® communication.

The word 'HART' then blinks on the display when Code 3 is selected. This locking function can only be disabled over HART® communication.

On-site operation is enabled by default.

Table 8: Dynamic HART® variables assignment

Variable	Meaning	Unit
Set point	Set point	%
Direction of action set point	Direction of action set point	%
Set point after transit time specification	Set point after transit time specification	%
Actual value (process variable)	Actual value (process variable)	%
Set point deviation e	Set point deviation e	%
Absolute total valve travel	Absolute total valve travel	–
Binary input status	0 = Not active 1 = Active 255 = –/–	–
Internal solenoid valve/forced venting status	0 = De-energized 1 = Energized 2 = Not installed	–
Condensed state	0 = No message 1 = Maintenance required 2 = Maintenance demanded 3 = Maintenance alarm 4 = Out of specification 7 = Function check	
Temperature	Temperature	°C
Sound pressure level (leakage detection)	Sound pressure level (leakage detection)	dB

7 Start-up and settings

! NOTICE

Risk of malfunction due to incorrect sequence of mounting, installation and start-up.

Keep the following sequence.

1. Remove the protective film from the pneumatic connections.
2. Mount the positioner on the control valve.
3. Connect the supply air.
4. Connect the electrical power.
5. Perform the start-up settings.

Reading after connecting the electrical power supply:

fESinG runs across the display and the  fault alarm icon appears and blinks on the display when the **positioner has not been initialized**. The reading indicates the lever position in degrees in relation to the mid-axis.

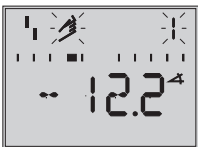

Reading when the positioner has not yet been initialized

Code 0 is displayed when a **positioner has been initialized**. The positioner is in the last active operating mode.



WARNING!

Risk of injury due to the actuator stem extending or retracting.

Do not touch or block the actuator stem.



Note:

The positioner performs a test in the start-up phase while following its automation task at the same time.

During the start-up phase, operation on site is unrestricted, yet write access is limited.

Perform the start-up settings in the same sequence as described (section 7.1 to section 7.6).

7.1 Defining the fail-safe position

Define the fail-safe position of the valve (0 %) taking the valve type and the actuator's direction of action into account. Position the AIR TO OPEN/AIR TO CLOSE slide switch accordingly:

- **AIR TO OPEN** setting
Signal pressure opens the valve e.g. for a fail-close valve
The AIR TO OPEN setting always applies to double-acting actuators.
- **AIR TO CLOSE** setting
Signal pressure closes the valve e.g. for a fail-open valve

For checking purposes: After successfully completing initialization, the positioner display must read 0 % in the valve fail-safe position and 100 % when the valve is open. If this is not the case, change the slide switch position and re-initialize the positioner.



Note:

The switch position is prompted prior to an initialization. After an initialization has been completed, changing the switch position does not have any effect on the operation of the positioner.

7.2 Adjusting the volume restriction Q

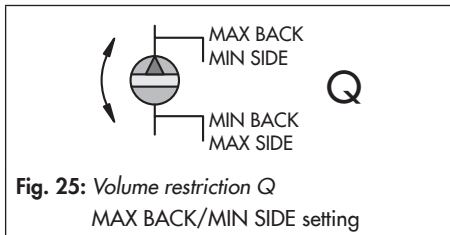

The volume restriction Q serves to adapt the air output capacity to the size of the actuator:

- Actuators with a **transit time < 1 s**, e.g. linear actuators with an effective area smaller than 240 cm², require a restricted air flow rate (MIN).
- Actuators with a **transit time ≥ 1 s** do not require the air flow rate to be restricted (MAX).

The position of volume restriction Q also depends on how the signal pressure is routed at the actuator in **SAMSON actuators**:

- The SIDE position applies for actuators with a signal pressure connection at the side, e.g. Type 3271-5.

- The BACK position applies for actuators with a signal pressure connection at the back, e.g. Type 3277-5.
- The SIDE restriction position always applies for actuators from other manufacturers.

Overview · Position of the volume restriction Q*

Signal pressure \ Transit time	<1 s	≥1 s
Connection at the side	MIN SIDE	MAX SIDE
Connection at the back	MIN BACK	MAX BACK

* Intermediate settings are not permitted.

The following applies to positioners with optional analog input x: the MIN SIDE setting must always be used for actuators with an air volume of less than one liter.



NOTICE

Malfunction due to changed start-up settings.
Initialize an initialized positioner again after the position of the volume restriction has been changed.

7.3 Adapting the display direction

To adapt the reading on the display to the mounting situation of the actuator, the display contents can be turned by 180°.

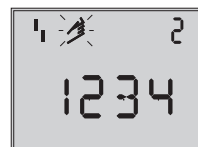

Reading direction for right attachment of pneumatic connections



Reading direction for left attachment of pneumatic connections

If the displayed data appear upside down, proceed as follows:

Turn → Code 2

Press , Code **2** blinks.

Turn → Required reading direction

Press to confirm reading direction.

7.4 Limiting the signal pressure

If the maximum actuator force may cause damage to the valve, the signal pressure must be limited.

Enable configuration at the positioner before limiting the signal pressure:



Note:

If no settings are entered within 120 seconds, the enabled configuration function becomes invalid.

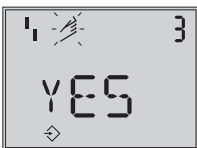

Enable configuration
Default: **No**

Turn → Code 3, display: **No**

Press , Code **3** blinks.

Turn → **YES**

Press , display:

Limit the signal pressure:

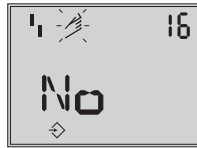

Pressure limit
Default: **No**

Turn → Code 16

Press , Code **16** blinks.

Turn until the required pressure limit (1.4/2.4/3.7 bar) appears.

Press to confirm the pressure limit setting.

7.5 Checking the operating range of the positioner

To check the mechanical attachment and the proper functioning, the valve should be moved through the operating range of the positioner in the manual mode with the manual set point.

Select manual mode:

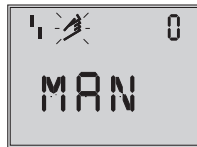

Operating mode
Default **MAN**

Turn → Code 0

Press , Code **0** blinks.

Turn → **MAN**

Press . The positioner changes to the manual mode (.

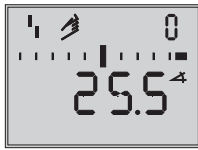
Check the operating range:

Manual set point w
(current angle of rotation is
indicated)

Turn  → Code 1

Press , Code 1 and  icon blink.

Turn  until the pressure in the positioner builds up, and the control valve moves to its final positions so that the travel/angle can be checked.

The angle of rotation of the lever on the back of the positioner is indicated. A horizontal lever (mid position) is equal to 0°.

To ensure the positioner is working properly, the outer bar elements must not blink while the valve is moving through the operating range.

Exit Code 1 by pressing the rotary pushbutton .

The permissible range has been exceeded when the displayed angle is more than 30° and the outer right or left bar element blinks. The positioner goes to the fail-safe position (SAFE).

After canceling the fail-safe position (SAFE) (see section 8.2.2) it is absolutely essential that you check the lever and pin position as described in section 4.

**WARNING!**

Risk of injury due to the actuator stem extending or retracting.

Before exchanging the lever or changing the pin position, disconnect the supply air and electrical auxiliary power.

7.6 Initialization

**NOTICE**

The process is disturbed by the movement of the actuator stem.

Do not initialize the positioner while the process is running; only perform an initialization during start-up with the shut-off valves closed.

A signal pressure above the maximum permissible limit will damage the valve.

Check the maximum permissible signal pressure of the control valve before starting initialization. If necessary, limit the signal pressure by connecting an upstream pressure reducing valve.

Malfunction due to changed mounting or installation circumstances. Reset the positioner to its default settings and re-initialize it after the positioner has been mounted on to another actuator or its mounting location has been changed.

During initialization the positioner adapts itself optimally to the friction conditions and the signal pressure required by the control valve. The type and extent of auto tuning depends on the initialization mode selected:

- **Maximum range (MAX)** (standard range)
Initialization mode for simple start-up of valves with two clearly defined mechanical end positions, e.g. three-way valves (see section 7.6.1)
- **Nominal range (NOM)**
Initialization mode for all globe valves (see section 7.6.2)
- **Manually selected range (MAN)**
Initialization mode for globe valves with an unknown nominal range (see section 7.6.3)
- **Substitute calibration (Sub)**
This mode allows a positioner to be replaced while the plant is running, with the least amount of disruption to the plant (see section 7.6.4).



Note:

For normal operation, simply start initialization by pressing the INIT key after mounting the positioner on the valve and defining the fail-safe position and setting the volume restriction. The positioner only needs to work with its default settings. If necessary, perform a reset (see section 7.8).



Alternating readings
Initialization in progress
Icon depending on initialization mode selected



Bar graph display indicating the progress of the initialization



Initialization successfully completed. Positioner in automatic mode (C)

The time required for the initialization procedure depends on the actuator transit time and can take a few minutes.

After a successful initialization, the positioner runs in closed-loop operation indicated by the C closed-loop operation icon.

A malfunctioning leads to the process being canceled. The initialization error is displayed according to how it has been classified by the condensed state. Refer to section 8.3.



Note:

When Code **48 - h0** = YES, the diagnostics automatically start to plot the reference graphs (drive signal steady-state d1 and hysteresis d2) after initialization has been completed. This is indicated by **IES1** and **d1** or **d2** appearing on the display in alternating sequence.

An error during the plotting of the reference graphs is indicated on the display over Code **48 - h1** and Code **81**.

The reference graphs do not have any effect on closed-loop operation.

Fail-safe position AIR TO CLOSE

If the slide switch is set to AIR TO CLOSE, the positioner automatically switches to the direction of action increasing/decreasing (↗↘) after initialization has been completed. This results in the following assignment between set point and valve position:

Fail-safe position	Direction of action	Set point Valve	
		CLOSED at	OPEN at
Actuator stem extends (FA) AIR TO OPEN	↗↗	0 %	100 %
Actuator stem retracts (FE) AIR TO CLOSE	↗↘	100 %	0 %

The tight-closing function has been activated.

Set Code 15 (final position w>) to 99 % for three-way valves.

Canceling an initialization process

An initialization procedure in progress can be canceled by pressing the rotary pushbutton (⊗). **STOP is displayed for three seconds and the positioner changes to the fail-safe position.**

Exit the fail-safe position again over Code 0 (see section 8.2.2).

7.6.1 MAX – Initialization based on maximum range

The positioner determines travel/angle of rotation of the closing member from the CLOSED position to the opposite travel stop and adopts this travel/angle of rotation as the operating range from 0 to 100 %.

Enable configuration:



Note:

If no settings are entered within 120 seconds, the enabled configuration function becomes invalid.

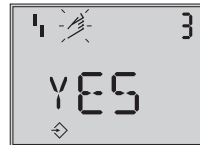

Default: **No**

Turn ⊗ → Code 3, display: **No**

Press ⊗, Code **3** blinks.

Turn ⊗ → **YES**

Press ⊗, display: ⊕

Select the initialization mode:



Default: **MAX**

Turn ⊗ → Code 6

Press ⊗.

Turn ⊗ → **MAX**

Press  to confirm the MAX as the initialization mode.

Start initialization:

→ Press INIT key.

The nominal travel/angle of rotation is indicated in % after initialization. Code 5 (nominal range) remains locked. The parameters for travel/angle range start (Code 8) and travel/angle range end (Code 9) can also only be displayed and modified in %.

For a reading in mm/°, enter the pin position (Code 4).

Enter the pin position:



Pin position
Default: **No**

Turn  → Code 4

Press , Code **4** blinks.

Turn  → Pin position on lever (see relevant section on attachment)

Press .

The reading of the nominal range appears in mm/°.

7.6.2 NOM – Initialization based on nominal range

The calibrated sensor allows the effective valve travel to be set very accurately. During initialization, the positioner checks whether the control valve can move through the indicated nominal range (travel or angle) with-

out collision. If this is the case, the indicated nominal range is adopted with the limits of travel/angle range start (Code 8) and travel/angle range end (Code 9) as the operating range.



Note:

The maximum possible travel must always be greater than the nominal travel entered. If this is not the case, initialization is automatically canceled (error message Code 52) because the nominal travel could not be achieved.

Enable configuration:



Note:

If no settings are entered within 120 seconds, the enabled configuration function becomes invalid.

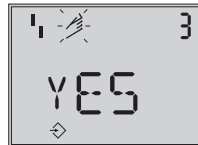

Default: **No**

Turn  → Code 3, display: **No**

Press , Code **3** blinks.

Turn  → **YES**

Press , display: 

Enter the pin position and nominal range:



Pin position
Default: **No**



Nominal range
(locked when Code 4 = No)

- Turn → Code 4
- Press , Code **4** blinks.
- Turn → Pin position on lever (see relevant section on attachment)
- Press .
- Turn → Code 5
- Press , Code **5** blinks.
- Turn → Nominal travel of the valve
- Press .

Select the initialization mode:



Init mode
Default: **MAX**

- Turn → Code 6
- Press , Code **6** blinks.
- Turn → **NOM**
- Press to confirm the NOM as the initialization mode.

Start initialization:

- Press INIT key.

- After initialization, check the direction of action (Code 7) and, if necessary, change it.

7.6.3 MAN – Initialization based on a manually selected range

Before starting initialization, move the control valve manually to the OPEN position. Turn the rotary pushbutton () clockwise in small steps. The valve must be moved with a monotonically increasing signal pressure. The positioner calculates the differential travel/angle from the OPEN and CLOSED positions and adopts it as the operating range with limits of lower travel/angle range value (Code 8) and upper travel/angle range value (Code 9).

Enable configuration:



Note:

If no settings are entered within 120 seconds, the enabled configuration function becomes invalid.



Enable configuration
Default: **No**

- Turn → Code 3, display: **No**
- Press , Code **3** blinks.
- Turn → **YES**
- Press , display:

Enter the pin position:



Pin position
Default: **No**

- Turn → Code 4
- Press , Code 4 blinks.
- Turn → Pin position on lever (see relevant section on attachment)
- Press .

Select the initialization mode:

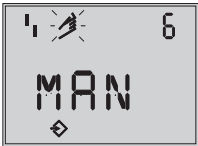

Init mode
Default: **MAX**

- Turn → Code 6
- Press , Code 6 blinks.
- Turn → **MAN**
- Press to confirm the **MAN** as the initialization mode.

Enter OPEN position:

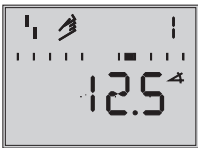

Manual set point
(current angle of rotation is indicated)

- Turn → Code 0
- Press , Code 0 blinks.
- Turn → **MAN**
- Press .
- Turn → Code 1

Press , Code 1 blinks.

Turn until the valve reaches its OPEN position.

Press to confirm the OPEN position.

Start initialization:

→ Press INIT key.

7.6.4 SUB – Substitute calibration

A complete initialization procedure takes several minutes and requires the valve to move through its entire travel range several times. This initialization mode, however, is an emergency mode, in which the control parameters are estimated and not determined by an initialization procedure. As a result, a high level of accuracy cannot be expected. You should always select a different initialization mode if the plant allows it.

The substitute calibration is used to replace a positioner while the process is running. For this purpose, the control valve is usually fixed mechanically in a certain position, or pneumatically by means of a pressure signal which is routed to the actuator externally. The blocking position ensures that the plant continues to operate with this valve position.

By entering the blocking position (Code 35), closing direction (Code 34), pin position (Code 4), nominal range (Code 5) and direction of action (Code 7), the positioner can calculate the positioner configuration.

NOTICE
 Perform a reset before re-initializing the positioner if the substitute positioner has already been initialized. Refer to section 7.8.

Enable configuration:

Note:
 If no settings are entered within 120 seconds, the enabled configuration function becomes invalid.

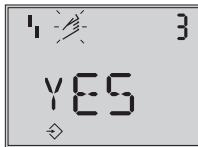

Enable configuration
 Default: **No**

Turn → Code 3, display: **No**
 Press , Code **3** blinks.
 Turn → **YES**
 Press , display:

Enter the pin position and nominal range:



Pin position
 Default: **No**



Nominal range
 (locked when Code 4 = No)

Turn → Code 4
 Press , Code **4** blinks.

Turn → Pin position on lever (see relevant section on attachment)
 Press .
 Turn → Code 5
 Press , Code **5** blinks.
 Turn → Nominal travel of the valve
 Press .

Select the initialization mode:

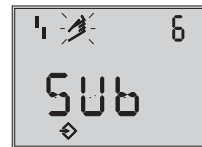

Init mode
 Default: **MAX**

Turn → Code 6
 Press .
 Turn → **SUB**
 Press to confirm the **SUB** as the initialization mode.

Enter the direction of action:



Direction of action
 Default:

Turn → Code 7
 Press , Code **7** blinks.
 Turn → Direction of action (/)
 Press .

Deactivate travel limit:



Travel limit
Default: **No**

Turn → Code 11

Press , Code **11** blinks.

Turn → **No**

Press .

Change pressure limit and control parameters:



Note:

Do not change the pressure limit (Code 16). Only change the control parameters K_p (Code 17) and T_V (Code 18) if the settings of the the replaced positioner are known.

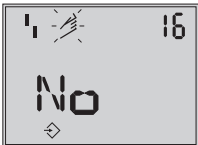

Pressure limit
Default: **No**



K_p level
Default **7**

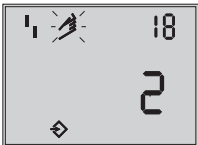

T_V level
Default **2**

Turn → Code 16/17/18

Press , Code **16/17/18** blinks.

Turn to set the control parameter selected.

Press to confirm the setting.

Enter closing direction and blocking position:



Closing direction (direction of rotation causing the valve to move to the CLOSED position (view on-to positioner display)
Default: CCL (counterclockwise)

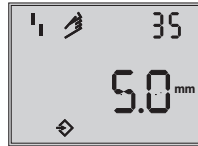

Blocking position
Default **0**

Turn → Code 34

Press , Code **34** blinks.

Turn → Closing direction (CCL = counterclockwise/CL = clockwise)

Press .

Turn → Code 35

Press , Code **35** blinks.

Turn → Blocking position, e.g. 5 mm (read off at travel indicator scale of the blocked valve or measure with a ruler).

Set the fail-safe position:

→ Set switch for the fail-safe position AIR TO OPEN or AIR TO CLOSE according to section 7.1.

→ Set volume restriction as described in section 7.2.

Start initialization:

→ Press INIT key.

The positioner switches to **MAN** mode.
The blocking position is indicated.



Note:

Since initialization has not been completed, the error code 76 (no emergency mode) and possibly also error code 57 (control loop) may appear on the display. These alarms do not influence the positioner's readiness for operation.

Cancel the blocking position and change to automatic mode (AUTO):

For the positioner to follow its set point again, the blocking position must be canceled and the positioner must be set to automatic mode as follows:

Turn → Code 1

Press , Code **1** and icon blink.

Turn in order to move the valve slightly past the blocking position.

Press to cancel mechanical blocking.

Turn → Code 0

Press , Code **0** blinks.

Turn → **AUTO**

Press .

The positioner switches to automatic mode.
The current valve position is indicated in %.



Note:

If the positioner shows a tendency to oscillate in automatic mode, the parameters K_p and T_v must be slightly corrected. Proceed as follows:

- Set T_v (Code 18) to **4**.
- If the positioner still oscillates, the gain K_p (Code 17) must be decreased until the positioner shows a stable behavior.

Zero point calibration

Finally, if process operations allow it, the zero point must be calibrated according to section 7.7.

7.7 Zero calibration

In case of inconsistencies in the closed position of the valve, e.g. with soft-seated plugs, it might be necessary to recalibrate zero.



WARNING!

Risk of injury due to the actuator stem extending or retracting.
Do not touch or block the actuator stem.



NOTICE

The process is disturbed by the movement of the actuator stem.
Do not perform zero calibration while the process is running. First isolate the plant by closing the shut-off valves.



Note:

The positioner must be connected to the supply air to perform the zero calibration.

Enable configuration:

Turn  → Code 3, display: **No**

Press , Code **3** blinks.

Turn  → **YES**

Press , display: 

Perform zero calibration:

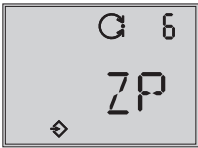

Init mode
Default MAX

Turn  → Code 6

Press , Code **6** blinks.

Turn  → **ZP**

➔ Press INIT key.

Zero calibration starts. The positioner moves the valve to the CLOSED position and recalibrates the internal electrical zero point.

Reset start-up parameters:

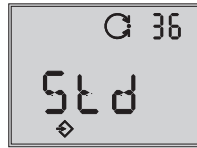

Reset
Default: **No**

Turn  → Code 36, display: **•••••**

Press , Code **36** blinks.

Turn  → **Std**

Press .

All start-up parameters as well as the diagnosis are reset to their default values.



Note:

Code 36 - diAG allows just the diagnosis data (EXPERTplus) to be reset.

Refer to the Operating Instructions for EXPERTplus valve diagnostics

▶ **EB 8389.**

7.8 Reset to default settings

This function resets all start-up and setting parameters as well as the diagnosis to the factory default settings (see code list in section 14).

Enable configuration:

Turn  → Code 3, display: **No**

Press , Code **3** blinks.

Turn  → **YES**

Press , display: 

8 Operation



WARNING!

*Risk of injury due to the actuator stem extending or retracting.
Do not touch or block the actuator stem.*

8.1 Enabling and selecting parameters

All codes and their meaning and default settings are listed in the code list in section 14.

Codes which are marked with an asterisk must be enabled with Code 3 before the associated parameters can be configured as described below.

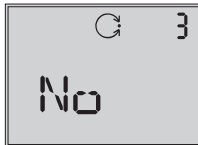

Code 3
Configuration not enabled

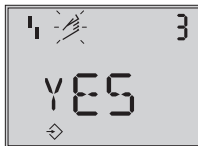

Configuration enabled

Turn → Code 3, display: **No**

Press , Code **3** blinks.

Change the setting in Code 3.

Turn → **YES**

Press , display:

Configuration is enabled.

You can now configure codes one after the other:

Turn to select the required code.

Press to activate the selected code. The code number starts to blink.

Turn to select the setting.

Press to confirm the selected setting.



Note:

If no settings are entered within 120 seconds, the enabled configuration function becomes invalid and the display returns to Code 0.

Cancel the setting:



Canceling the reading

To cancel a value before it is confirmed (by pressing) proceed as follows:

Turn → **ESC**

Press .

The entered value is not adopted.

8.2 Operating modes

8.2.1 Automatic and manual modes

After initialization has been completed successfully, the positioner is in automatic mode (AUTO).

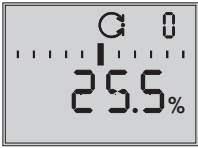

Automatic mode



Switching to manual mode (MAN)



Turn  → Code 0

Press , display: **AUTO**, Code 0 blinks.

Turn  → **MAN**

Press . The positioner changes to the manual mode (.

The manual mode starts using the last set point of the automatic mode, ensuring a bumpless changeover. The current position is displayed in %.

Adjust the manual set point



Turn  → Code 1

Press , Code 1 blinks.

Turn  until sufficient pressure has been built up in the positioner and the control valve moves to the required position.



Note:

The positioner automatically returns to Code 0 if no settings are made within 120 seconds, but remains in the manual mode.

Switch to automatic mode

Turn  → Code 0

Press , Code 0 blinks.

Turn  → **AUTO**

Press . The positioner switches to automatic mode.

8.2.2 Fail-safe position (SAFE)

If you want to move the valve to the fail-safe position determined during start-up (see section 7.1), proceed as follows:



Turn  → Code 0

Press , display: current operating mode (**AUTO** or **MAN**), Code 0 blinks.

Turn  → **SAFE**

Press , display: **S**

The valve moves to the fail-safe position.

If the positioner has been initialized, the current valve position in % is indicated on the display.

Exit the fail-safe position

Turn  → Code 0

Press , Code 0 blinks.

Turn  and select the required operating mode (**AUTO** or **MAN**).

Press .

The positioner switches to the operating mode selected.

8.3 Fault/malfunction

A status classification is assigned to all status and fault alarms in the positioner. The default settings of the status classification are listed in the code list.



Note:

The assignment of the status classification can be changed in TROVIS-VIEW and over the parameters of the DD. Refer to the Operating Instructions for the valve diagnostics ► EB 8389 on the enclosed CD-ROM for more details.

To provide a better overview, the classified messages are summarized in a condensed state for the positioner according to the NAMUR Recommendation NE 107. The status messages are divided into the following categories:

– **Maintenance alarm**

The positioner cannot perform its control task due to a functional fault in the positioner itself or in one of its peripherals or an initialization has not yet been successfully completed.

– **Maintenance required**

The positioner still performs its control task (with restrictions). A maintenance demand or above average wear has been determined. The wear tolerance will soon be exhausted or is reducing at a faster rate than expected. Maintenance is necessary in the medium term.

– **Maintenance demanded**

The positioner still performs its control task (with restrictions). A maintenance demand or above average wear has been determined. The wear tolerance will soon be exhausted or is reducing at a faster rate than expected. Maintenance is necessary in the short term.

– **Out of specification**



The positioner is running outside the specified operating conditions.



Note:

If an event is classified as “No message”, this event does not have any affect on the condensed state.

The condensed state is displayed represented by the following icons:

Condensed state	Positioner display
Maintenance alarm	
Function check	Text e.g. <i>tESing</i> , <i>TunE</i> or <i>tESr</i>
Maintenance required/maintenance demanded	
Out of specification	 blinking

If the positioner has not been initialized, the maintenance alarm icon (⚠) is displayed as the positioner cannot follow its set point.

If fault alarms exist, the possible source of error is displayed in Code 49 onwards. In this case, **Err** is displayed.

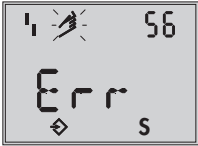

Example:
Error caused by pin position

Refer to the code list (section 14) for possible causes and the recommended action.

Fault alarm output

'Maintenance alarm' as the condensed state causes the optional fault alarm output to be switched.

- The 'Function check' condensed state can also activate the fault alarm output (Code 32).
- The 'Maintenance required/Maintenance demanded' condensed state can also activate the fault alarm output (Code 33).

8.3.1 Confirming error messages

Enable configuration:



Note:

If no settings are entered within 120 seconds, the enabled configuration function becomes invalid.

Turn  → **YES**

Press , display: 

Confirming error message:

Turn  → Select the error code that you want to confirm.

Press .

The error message is confirmed.

Turn  → Code 3, display: **No**

Press , Code **3** blinks.

9 Adjusting the limit switch

The positioner version with an inductive limit switch has an adjustable tag (1) mounted on the axis of rotation, which operates the proximity switch (3).

For operation of the inductive limit switch, the corresponding switching amplifier (see section 5.2.1) must be connected to the output circuit.

When the tag (1) is located in the inductive field of the switch, the switch assumes a high resistance. When it moves outside the field, the switch assumes a low resistance.

Normally, the limit switch is adjusted in such a way that it will provide a signal in both end positions of the valve. The switch, how-

ever, can also be adjusted to indicate intermediate valve positions.

The required switching function, i.e. whether the output relay is to be picked up or released when the tag enters the field, must be selected at the switching amplifier, if required.



Note:

The inductive limit switch replaces the software limit switch A1 with terminal assignment +41/-42.

Each switching position can optionally be set to indicate when the tag has entered the field, or when it has left the field.

The second software limit switch remains effective, the function of the software limit switch A1 is disabled.

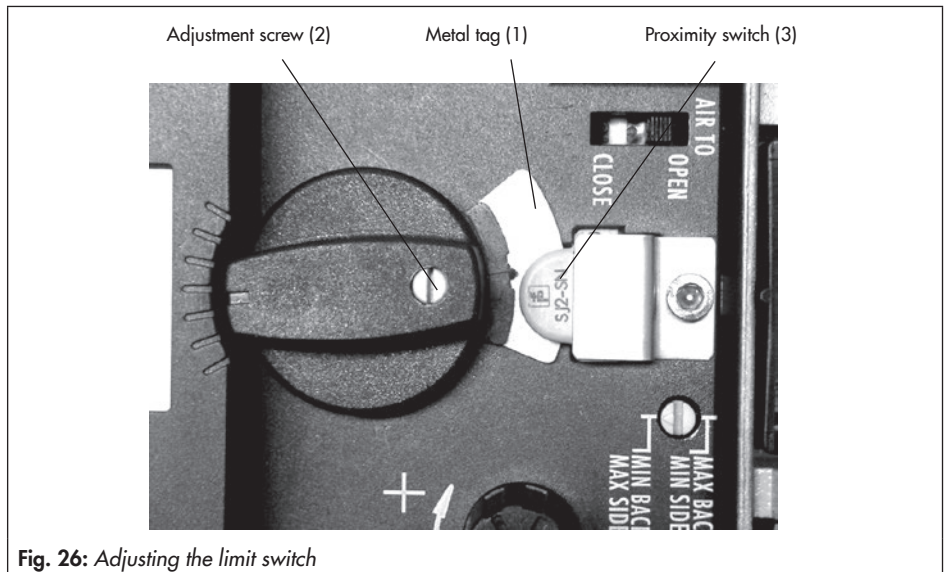

Fig. 26: Adjusting the limit switch

Software adaptation

- Code 38 (inductive alarm is set to YES).
- The inductive limit switch is connected to the terminals +41/-42.
- The device is set up accordingly in the delivered state.

Adjusting the switching point

**Note:**

During adjustment or testing, the switching point must always be approached from mid-position (50 %).

To guarantee the switching under all ambient conditions, adjust the switching point approx. 5 % before the mechanical stop (OPEN – CLOSED).

For CLOSED position:

1. Initialize the positioner.
2. Move the valve to 5 % in the MAN mode (see display).
3. Adjust the tag at the yellow adjustment screw (2) until the tag enters or leaves the field and the switching amplifier responds.

You can measure the switching voltage as an indicator.

Contact function:

- Tag leaving the field > contact is closed.
- Tag entering the field > contact is opened.

For OPEN position:

1. Initialize the positioner.

2. Move the valve to 95 % in the MAN mode (see display).
3. Adjust the tag (1) at the yellow adjustment screw (2) until the tag enters or leaves the field of the proximity switch (3).
You can measure the switching voltage as an indicator.

Contact function:

- Tag leaving the field > contact is closed.
- Tag entering the field > contact is opened.

9.1 Retrofitting an inductive limit switch

Required retrofit kit:

Limit switch Order no. 1400-7460

**Note:**

The same requirements apply to retrofitting an inductive limit switch as to servicing the positioner. For explosion-protected positioners, the requirements in section 11 need to be kept. Check the "Limit switch, inductive" box on the nameplate after installing the limit switch.

1. Take off the rotary pushbutton (3) and cap (1), unthread the five fastening screws (2) and lift off the plastic cover (9) together with the display, taking care not to damage the ribbon cable (between PCB and display).
2. Use a knife to cut an opening at the marked location (4).
3. Push the connector (11) with cable through the opening and secure the proximity switch (7) on the cover with a dot of glue.
4. Remove the jumper (8801-2267) at the socket X7 of the top board and insert the cable connector (11).
5. Guide the cable in such a manner that the plastic cover can be placed back onto the positioner. Insert the fixing screws (2) and screw tight. Attach the clamping plate (8) onto the proximity switch.
6. Attach the rotary switch (5). Make sure the flattened side of the positioner shaft is turned so that the rotary switch (5) can be attached with the metal tag next to the proximity switch.
7. On start-up of the positioner, set the option inductive alarm under Code 38 from **No** to **YES**.

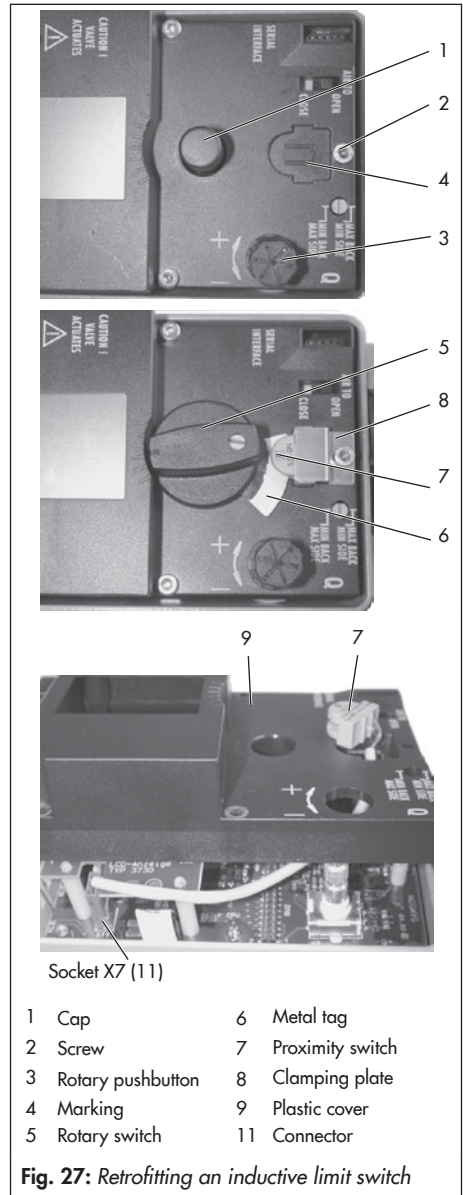

Fig. 27: Retrofitting an inductive limit switch

10 Maintenance

The positioner does not require any maintenance.

There are filters with a 100 µm mesh size in the pneumatic connections for supply and output which can be removed and cleaned, if required.

The maintenance instructions of any upstream supply air pressure reducing stations must be observed.

11 Servicing explosion-protected devices

If a part of the device on which the explosion protection is based needs to be serviced, the device must not be put back into operation until a qualified inspector has assessed it according to explosion protection requirements, has issued an inspection certificate or given the device a mark of conformity. Inspection by a qualified inspector is not required if the manufacturer performs a routine test on the device before putting it back into operation. Document the passing of the routine test by attaching a mark of conformity to the device. Replace explosion-protected components only with original, routine-tested components from the manufacturer.

Devices that have already been operated outside hazardous areas and are intended for future use inside hazardous areas must comply with the safety requirements placed on serviced devices. Before being operated

inside hazardous areas, test the devices according to the specifications for servicing explosion-protected devices.

Read section 13 for maintenance, calibration and adjustment work inside and outside hazardous areas.

12 Firmware update (serial interface)

Firmware updates on positioners currently in operation can be performed as follows:

When updates are performed by a service employee appointed by SAMSON, the update is confirmed on the device by the test mark assigned by SAMSON's Quality Assurance.

In all other cases, only plant operator personnel with written approval may perform updates. Updates are to be confirmed by approved personnel on the device.

Laptops and PCs connected to the power supply must not be used without an additional protective circuit.

This does not apply to laptops in battery operation. In this case, it is assumed that a battery-powered laptop runs briefly for software programming or testing purposes.

a) Updates outside the hazardous area:

Remove the positioners from the plant. Update them outside the hazardous area.

b) Updates on site:

Updates on site are only permitted after the plant operator presented a signed hot work permit.

After updating has been completed, add the current firmware to the nameplate; this can be done using labels.

13 Maintenance, calibration and work on equipment

Interconnection with intrinsically safe circuits to check or calibrate the equipment inside or outside hazardous areas is to be performed only with intrinsically safe current/voltage calibrators and measuring instruments to rule out any damage to components relevant to explosion protection.

Observe the maximum permissible values specified in the certificates for intrinsically safe circuits.

14 Code list



Code no.	Parameter – Readings/ values [default setting]	Description																											
Note: Codes with marked with an asterisk (*) must be enabled with Code 3 prior to configuration.																													
0	Operating mode [MAN] Manual mode AUTO Automatic mode SAFE Fail-safe position ESC Cancel	Switchover from automatic to manual mode is bumpless. In fail-safe position, the S icon is displayed. In MAN and AUTO mode, the system deviation is represented by the bar graph elements. The reading indicates the valve position or angle of rotation in % when the positioner is initialized. If the positioner is not initialized, the position of the lever in relation to the longitudinal axis is displayed in degrees (°).																											
1	Manual w [0] to 100 % of the nominal range	Adjust the manual reference variable with the rotary pushbutton. The current travel/angle is displayed in % when the positioner is initialized. If the positioner is not initialized, the position of the lever in relation to the longitudinal axis is indicated in degrees (°). Note: can only be selected when Code 0 = MAN																											
2	Reading direction 1234, ↻, ESC	The reading direction of the display is turned by 180°.																											
3	Enable configuration [No], YES, ESC	Enables changing of data (automatically deactivated when the rotary pushbutton has not been operated for 120 s). HART blinks on the display when the on-site operation is locked over HART® communication. Codes marked with an asterisk (*) can only be read and not overwritten. Similarly, codes can only read over the SSP interface.																											
4*	Pin position [No], 17, 25, 35, 50, 70, 100, 200, 300 mm, 90° with rotary actuators, ESC Note: If you select a pin position in Code 4 that is too small, the positioner switches to SAFE mode for reasons of safety.	Follower pin must be mounted in the proper position depending on the valve travel/opening angle. Pin position must be entered for nominal (NOM) or substitute (SUB) initialization. <table border="1" style="margin-left: auto; margin-right: auto;"> <thead> <tr> <th>Pin position Code 4</th> <th>Standard Code 5</th> <th>Adjustment range Code 5</th> </tr> </thead> <tbody> <tr> <td>17</td> <td>7.5</td> <td>3.6 to 17.7</td> </tr> <tr> <td>25</td> <td>7.5</td> <td>5.0 to 25.0</td> </tr> <tr> <td>35</td> <td>15.0</td> <td>7.0 to 35.4</td> </tr> <tr> <td>50</td> <td>30.0</td> <td>10.0 to 50.0</td> </tr> <tr> <td>70</td> <td>40.0</td> <td>14.0 to 70.7</td> </tr> <tr> <td>100</td> <td>60.0</td> <td>20.0 to 100.0</td> </tr> <tr> <td>200</td> <td>120.0</td> <td>40.0 to 200.0</td> </tr> <tr> <td>90°</td> <td>90.0</td> <td>24.0 to 100.0</td> </tr> </tbody> </table>	Pin position Code 4	Standard Code 5	Adjustment range Code 5	17	7.5	3.6 to 17.7	25	7.5	5.0 to 25.0	35	15.0	7.0 to 35.4	50	30.0	10.0 to 50.0	70	40.0	14.0 to 70.7	100	60.0	20.0 to 100.0	200	120.0	40.0 to 200.0	90°	90.0	24.0 to 100.0
Pin position Code 4	Standard Code 5	Adjustment range Code 5																											
17	7.5	3.6 to 17.7																											
25	7.5	5.0 to 25.0																											
35	15.0	7.0 to 35.4																											
50	30.0	10.0 to 50.0																											
70	40.0	14.0 to 70.7																											
100	60.0	20.0 to 100.0																											
200	120.0	40.0 to 200.0																											
90°	90.0	24.0 to 100.0																											

Code no.	Parameter – Readings/ values [default setting]	Description
5*	Nominal range mm or angle °, ESC	Nominal valve travel or opening angle must be entered for nominal (NOM) or substitute (Sub) initialization. The possible adjustment range depends on the pin position from the table for Code 4. Indicates maximum travel/angle reached during initialization after initialization has been successfully completed.
6*	Init mode [MAX] Maximum range NOM Nominal range MAN Manual setting Sub Emergency mode ZP Zero calibration ESC Cancel	Select the initialization mode MAX: Travel/angle of the closure member from the CLOSED position to the opposite stop in the actuator. NOM: Travel/angle of the closure member measured from the CLOSED position to the indicated OPEN position. MAN: Manually selected range Sub: Substitute calibration (without initialization)
7*	w/x [↗] Increasing/increasing ↘ Increasing/decreasing ESC	Direction of action of the set point w in relation to the travel/angle x Automatic adaptation: AIR TO On completing initialization, the direction of action remains increasing/ increasing (↗). A globe valve opens as the set point increases. OPEN: AIR TO On completing initialization, the direction of action changes to increasing/decreasing (↘). A globe valve closes as the set point increases. CLOSE:
8*	Travel/angle range start (lower x-range value) [0.0] to 80.0 % of the nominal range, ESC Note: Specified in mm or angle ° provided Code 4 is activated.	Lower range value for travel/angle in nominal or operating range The operating range is the actual travel/angle of the valve and is limited by the lower travel/angle range value (Code 8) and the upper travel/angle range value (Code 9). Usually, the operating range and the nominal range are identical. The nominal range can be limited to the operating range by the lower and upper x-range values. The value is displayed or must be entered. The characteristic is adapted. See also the example in Code 9.

Code no.	Parameter – Readings/values [default setting]	Description
9*	<p>Travel/angle range end (upper x-range value) 20.0 to [100.0 %] of the nominal range, ESC</p> <p><i>Note: Specified in mm or angle ° provided Code 4 is activated.</i></p>	<p>Upper range value for travel/angle in nominal or operating range The value is displayed or must be entered. The characteristic is adapted.</p> <p>Example: The operating range is modified, for example, to limit the range of a control valve which has been sized too large. For this function, the entire resolution range of the set point is converted to the new limits. 0 % on the display corresponds to the adjusted lower limit and 100 % to the adjusted upper limit.</p>
10*	<p>Travel/angle lower limit (lower x-limit) 0.0 to 49.9 % of the operating range, [No], ESC</p>	<p>Limits travel/opening angle to the entered value (lower limit). The characteristic is not adapted.</p> <p>The characteristic is not adapted to the reduced range. See also the example in Code 11.</p>
11*	<p>Travel/angle upper limit (upper x-limit) 50.0 to 120.0 %, [100 %] of the operating range, No, ESC</p>	<p>Limits travel/angle to the entered value (upper limit). The characteristic is not adapted.</p> <p>Example: In some applications, it is better to limit the valve travel, e.g. if a certain minimum medium flow is required or a maximum flow must not be reached.</p> <p>The lower limit must be adjusted with Code 10 and the upper limit with Code 11.</p> <p>If a tight-closing function has been set up, it has priority over the travel limitation.</p> <p>When set to No, the valve can be opened past the nominal travel with a set point outside of the 0 to 100 % range.</p>
12*	<p>w-start [0.0] to 75.0 % of the set point range, ESC</p>	<p>The lower range value of the set point range must be lower than upper range value (w-end), 0 % = 4 mA.</p> <p>The set point range is the difference between w-end and w-start, and must be $\Delta w \geq 25 \% = 4 \text{ mA}$.</p> <p>When the set point range of 0 to 100 % = 4 to 20 mA, the valve must move through its entire operating range from 0 to 100 % travel/angle of rotation.</p> <p>In split-range operation, the valves operate with smaller set points. The control signal of the control unit to control two valves is divided such, for instance, that the valves move through their full travel/angle of rotation at only half the input signal (first valve set to 0 to 50 % = 4 to 12 mA and second valve set to 50 to 100 % = 12 to 20 mA).</p>

Code no.	Parameter – Readings/ values [default setting]	Description
13*	w-end 25.0 to [100.0 %] of the set point range, ESC	The upper range value of the set point range must be greater than lower range value (w-start). 100.0 % = 20 mA
14*	Set point cutoff decrease (w-start) 0.0 to 49.9 %, [1.0 %] of the span adjusted in Code 12/13, No, ESC	If the set point w reaches up to the entered percentage at the final value that causes the valve to close, the actuator is immediately completely vented (with AIR TO OPEN) or filled with air (with AIR TO CLOSE). This action always lead to maximum tight-closing of the valve. Codes 14/15 have priority over Codes 8/9/10/11. Codes 21/22 have priority over Codes 14/15.
15*	Set point cutoff increase (w-end) 50.0 to 100.0 % of the span adjusted in Code 12/13, [No], ESC	If the set point w reaches up to the entered percentage at the final value that causes the valve to open, the actuator is immediately filled with air (with AIR TO OPEN) or completely vented (with AIR TO CLOSE). This action always lead to the valve being completely opened. Codes 14/15 have priority over Codes 8/9/10/11. Codes 21/22 have priority over Codes 14/15. Example: Set the end position w > to 99 % for three-way valves.
16*	Pressure limit 1.4 bar, 2.4 bar, 3.7 bar, [No], ESC	The signal pressure to the actuator can be limited in stages. After changing a pressure limit already set, the actuator must be vented once (e.g. by selecting the fail-safe position (SAFE) over Code 0). NOTICE: Do not activate pressure limitation for double-acting actuators (with fail-safe position AIR TO OPEN).
17*	Proportional-action coefficient K_p (level) 0 to 17, [7], ESC	Read or change K_p Note concerning changing the K_p and T_v levels: During positioner initialization, the values for K_p and T_v are optimally set. If the positioner tends to overshoot impermissibly due to other disturbances, the K_p and T_v levels can be adapted accordingly after initialization. Increment T_v level until desired behavior is reached or when the maximum value of 4 is reached, the K_p level can be decreased in increments. NOTICE: K_p level changes affect the set point deviation.

Code no.	Parameter – Readings/ values [default setting]	Description
18*	Derivative-action time T_V (level) 1, [2], 3, 4, No, ESC	Read or change T_V (see K_p level) A change of the T_V level has no effect on the system deviation.
19*	Tolerance band 0.1 to 10.0 %, [5.0 %] of the operating range, ESC	Used for error monitoring. Determination of the tolerance band in relation to the operating range. Associated lag time (30 s) is a reset criterion. If a transit time is determined during initialization which is six times longer than 30 s, the six-fold transit time is accepted as the lag time.
20*	Characteristic [0] to 9, ESC	Select characteristic 0 Linear 1 Equal percentage 2 Reverse equal percentage 3 SAMSON butterfly valve, linear 4 SAMSON butterfly valve, equal percentage 5 VETEC rotary plug valve, linear 6 VETEC rotary plug valve, equal percentage 7 Segmented ball valve, linear 8 Segmented ball valve, equal percentage 9 User-defined (defined over operator software) Note: The various characteristics are listed in the Appendix (section 16).
21*	Required transit time OPEN (w ramp open) [0] to 240 s, ESC	Time required to move through the operating range when the valve opens. Limitation of the transit time (Code 21 and 22): For some applications it is recommendable to limit the transit time of the actuator to prevent it from engaging too fast in the running process. Code 21 has priority over Code 15. NOTICE: The function is not activated when the fail-safe function or solenoid valve is triggered nor upon failure of the auxiliary power.

Code no.	Parameter – Readings/ values [default setting]	Description
22*	Required transit time CLOSED (w ramp closed) [0] to 240 s, ESC	Time required to move through the operating range when the valve closes. Code 22 has priority over Code 14. NOTICE: <i>The function is not activated when the fail-safe function or solenoid valve is triggered nor upon failure of the auxiliary power.</i>
23*	Total valve travel [0] to $99 \cdot 10^7$, RES, ESC Exponential reading from 9999 travel cycles on-wards	Totaled full valve travel cycle Can be reset to 0 by selecting ESC. Note: <i>The total valve travel is saved in a non-volatile memory after every 1000 full valve travel cycle.</i>
24*	LV total valve travel 1000 to $99 \cdot 10^7$ [1.000000], ESC Exponential reading from 9999 travel cycles on-wards	Limit value of total valve travel. If the limit is exceeded, the  and  icons are indicated.



Code no.	Parameter – Readings/values [default setting]	Description
25*	Alarm mode 0 to 3, [2], ESC	<p>Switching mode of software limit switch alarms A1 and A2 when activated (when the positioner is initialized).</p> <p>1) Explosion-protected version according to EN 60947-5-6</p> <p>0: A1 ≥ 2.2 mA A2 ≤ 1.0 mA 1: A1 ≤ 1.0 mA A2 ≤ 1.0 mA 2: A1 ≥ 2.2 mA A2 ≥ 2.2 mA 3: A1 ≤ 1.0 mA A2 ≥ 2.2 mA</p> <p>2) Version without explosion protection</p> <p>0: A1 R = 348 Ω A2 Non-conducting 1: A1 Non-conducting A2 Non-conducting 2: A1 R = 348 Ω A2 R = 348 Ω 3: A1 Non-conducting A2 R = 348 Ω</p> <p>When a positioner has not been initialized, the software limit switches always register the signal as in the state of no response. If there is no mA signal at the terminals 11/12, the software limit switches both switch to ≤ 1.0 mA (Ex) or non-conducting (without explosion protection).</p> <p>Note: The fault alarm output always switches to ≤ 1.0 mA/non-conducting in case of a fault; it has ≥ 2.2 mA/R = 348 Ω when there is no fault.</p>
26*	Limit A1 0.0 to 100.0 %, [2.0 %] of the operating range, No, ESC	<p>Alarm A1 responds when the value falls below the limit. Software limit value A1 is displayed or can be changed in relation to the operating range. The setting has no effect when an inductive limit switch is installed.</p>
27*	Limit A2 0.0 to 100.0 %, [98.0 %] of the operating range, No, ESC	<p>Alarm A2 responds when the value falls below the limit. Software limit value A2 is displayed or can be changed in relation to the operating range.</p>

Code no.	Parameter – Readings/values [default setting]	Description
28*	Alarm test Reading direction: Standard Turned [No] [No] RUN 1 1 RUN RUN 2 2 RUN RUN 3 3 RUN ESC ESC	Test of software limit switch alarms A1 and A2 as well as of fault alarm contact A3. If the test is activated, the switch is switched five times. RUN 1/1 RUN: software limit switch A1 to ≥ 2.2 mA RUN 2/2 RUN: software limit switch A2 to ≥ 2.2 mA RUN 3/3 RUN: fault alarm switch A3 to ≤ 1.0 mA
29*	Position transmitter x/ix ³⁾ [↗↗], ↘↘, ESC	Operating direction of the position transmitter: it indicates assignment between travel/angle position and output signal i based on CLOSED position. The operating range (see Code 8) of the valve is represented by the 4 to 20 mA signal. Values exceeding or falling below the limits 2.4 to 21.6 mA can be represented. When the positioner has not been mounted (reference variable smaller than 3.6 mA), the signal is 0.9 mA and 3.8 mA the positioner has not been initialized. When YES is set in Code 32, the position transmitter issues the value as per Code 30 during initialization or zero calibration. When NO is set in Code 32, 4 mA is issued during a running calibration.
30*	Fault alarm ix ³⁾ HI, LO, [No], ESC	Select if and how alarms that cause the fault alarm contact to be switched are also indicated by the position transmitter. HI ix = 21.6 ± 0.1 mA or LO ix = 2.4 ± 0.1 mA
31*	Position transmitter test ³⁾ -10.0 to 110.0 % of the operating range, [default value is last indicated value of the position transmitter], ESC	Testing the position transmitter. Values can be entered in relation to the operating range. The momentary valve position is used in initialized positioners locally as the start value (bumpless changeover to the test mode). On testing over software, the entered simulation value is issued as the position feedback signal for 30 seconds.
	³⁾ Analog position transmitter: Code 29/30/31 can only be selected if the position transmitter (optional) is installed.	

Code no.	Parameter – Readings/ values [default setting]	Description
32*	Error message in case of 'Function check' condensed state [YES], No, ESC	<p>YES: Error message also in case of 'Function check' condensed state</p> <p>No: 'Function check' condensed state does not cause an error message to be issued</p> <p>Note: <i>Regardless of the condensed state, the fault alarm output always switches when the error codes 57, 58, 60, 62 and 64 to 70, 76 are issued.</i></p>
33*	Error message in case of condensed state 'Maintenance required' [YES], No, ESC	<p>YES: Error message only in case of condensed state 'Maintenance alarm' and 'Maintenance required'</p> <p>No: Error message only in case of condensed state 'Maintenance alarm'</p> <p>Note: <i>Regardless of the condensed state, the fault alarm output always switches when the error codes 57, 58, 60, 62 and 64 to 70, 76 are issued.</i></p>
34*	Closing direction CL, [CCL], ESC	<p>CL: Clockwise</p> <p>CCL: Counterclockwise</p> <p>Direction of rotation to reach the valve's CLOSED position (view onto rotary switch with positioner cover open).</p> <p>Needs only be entered in SUB initialization mode (Code 6).</p>
35*	Blocking position [0.0] mm/° /%, ESC	<p>Enter the blocking position (distance to CLOSED position)</p> <p>Only necessary with SUB initialization mode.</p>
36*	Reset [No], Std, diAG, ESC	<p>Std: Resets all parameters and diagnosis data to their default settings. After a reset, the positioner must be re-initialized.</p> <p>diAG: Resets diagnosis data only. Plotted reference graphs and logs remain saved. The positioner does not need to be re-initialized.</p>
37*	Position transmitter No, YES	<p>Read only</p> <p>Indicates whether an optional position transmitter is installed.</p>
38*	Inductive alarm [No], YES, ESC	<p>Indicates whether the inductive limit switch option is installed or not.</p>

Code no.	Parameter – Readings/ values [default setting]	Description
39	Set point deviation e info -99.9 to 99.9 %	Read only Indicates the deviation from the target position ($e = w - x$).
40	Transit time Open info [0] to 240 s	Read only Minimum opening time determined during initialization.
41	Transit time Closed info [0] to 240 s	Read only Minimum closing time determined during initialization.
42	Auto-w info 0.0 to 100.0 % of the span	Read only Indicates the applied automatic set point with corresponding 4 to 20 mA signal.
43	Firmware info	Read only Indicates the positioner type and current firmware version in alternating sequence.
44	y info [0] to 100 %, OP, MAX, ---	Read only Indicates the control signal y in % in relation to the travel range determined during initialization. MAX: The positioner builds up its maximum output pressure, see description in Code 14 and 15. OP: The positioner vents completely, see description in Code 14 and 15. ---: The positioner is not initialized.
45	Solenoid valve info YES, HIGH/LOW, No	Read only Indicates whether a solenoid valve is installed or not. If a voltage supply is connected at the terminals of the installed solenoid valve, YES and HIGH appear on the display in alternating sequence. If a voltage supply is not connected (actuator vented, fail-safe position indicated on the display by the S icon), YES and LOW appear on the display in alternating sequence.
46*	Polling address [0] to 63, ESC	Select bus address
47*	Write protection HART® YES, [No], ESC	When write protection is active, device data can be read, but not overwritten over HART® communication.
48* 49*	Diagnostic parameters ▶ EB 8389	

**Note:**

The error codes listed in the following appear in the display corresponding to their status classification set over the condensed state (Maintenance required/Maintenance demanded: , Out of specification:  blinking, Maintenance alarm: ). If “No message” is assigned to the error code as the status classification, the error is not included in the condensed state.

A status classification is assigned to every error code in the default setting. The status classification of error codes can also be changed as required using an operator software (e.g. TROVIS-VIEW).

Initialization errors

Error codes – Recommended action		Condensed state message active, when prompted, Err appears. When fault alarms exist, they are displayed here.
50	x > permissible range	Value of measuring signal too high or too low; the lever operates near its mechanical stops. <ul style="list-style-type: none"> • Pin not mounted properly • Bracket slipped in case of NAMUR attachment or positioner is off center. • Follower plate not mounted properly.
	Status classification	[Maintenance required]
	Recommended action	Check attachment and pin position, set operating mode from SAFE to MAN and re-initialize the positioner.
51	$\Delta x < \text{permissible range}$	Insufficient measuring span of the lever. <ul style="list-style-type: none"> • Pin not mounted properly • Wrong lever An angle of rotation smaller than 16° at the positioner shaft only generates an alarm. An angle below 9° leads to the initialization being canceled.
	Status classification	[Maintenance required]
	Recommended action	Check attachment and re-initialize the positioner.

Error codes – Recommended action		Condensed state message active, when prompted, Err appears. When fault alarms exist, they are displayed here.
52	Attachment	<ul style="list-style-type: none"> Invalid positioner attachment. Nominal travel/angle (Code 5) could not be achieved during NOM initialization (no tolerance downwards permissible). Mechanical or pneumatic fault, e.g. wrong lever selected or supply pressure too low to move to the required position.
	Status classification	[Maintenance required]
	Recommended action	<p>Check attachment and supply pressure. Re-initialize the positioner.</p> <p>Under certain circumstances, it may be possible to check the maximum travel/angle by entering the actual pin position and then performing a MAX initialization.</p> <p>After initialization has been completed, the Code 5 indicates the maximum achieved travel or angle.</p>
53	Initialization time exceeded (Init time >)	<p>Initialization takes too long. The positioner returns to the previous operating mode.</p> <ul style="list-style-type: none"> No pressure in supply line or pneumatic leakage Supply air failure during initialization
	Status classification	[Maintenance required]
	Recommended action	Check attachment and supply air line. Re-initialize the positioner.
54	Initialization – solenoid valve	<ol style="list-style-type: none"> A solenoid valve is installed (Code 45 = YES) and has not been connected or not properly. As a result, actuator pressure cannot build up. The alarm is generated when you attempt to initialize the positioner. If you attempt to initialize the positioner from the fail-safe position (SAFE).
	Status classification	[Maintenance required]
	Recommended action	<ol style="list-style-type: none"> Check connection and supply voltage of the solenoid valve (Code 45 High/Low). Set the MAN mode in Code 0. Re-initialize the positioner.

Error codes – Recommended action		Condensed state message active, when prompted, Err appears. When fault alarms exist, they are displayed here.
55	Transit time too short (transit time <)	Actuator transit times detected during initialization are so short that optimal positioner tuning is impossible.
	Status classification	[Maintenance required]
	Recommended action	Check the volume restriction setting as described in section 7.2. Re-initialize the positioner.
56	Pin position	Initialization canceled because selected NOM and SUB initialization modes require the pin position to be entered.
	Status classification	[Maintenance required]
	Recommended action	Enter pin position over Code 4 and nominal travel/angle over Code 5. Re-initialize the positioner.

Operational error

Error codes – Recommended action		Condensed state message active, when prompted, Err appears. When fault alarms exist, they are displayed here.
57	Control loop Additional indication at the fault alarm contact.	Control loop error, the valve no longer follows the controlled variable within tolerable times (tolerance band alarm Code 19). <ul style="list-style-type: none"> • Actuator blocked • Positioner attachment shifted subsequently • Supply pressure no longer suffices.
	Status classification	[Maintenance required]
	Recommended action	Check attachment.
58	Zero point	Zero point incorrect Error can occur when the positioner's attachment position is shifted or when the valve trim is worn, particularly with soft-sealed plugs.
	Status classification	[Maintenance required]
	Recommended action	Check valve and attachment of the positioner. If OK, perform a zero calibration over Code 6 (see section 7.7). We recommend to re-initialize the positioner if zero deviates by more than 5 %.

Error codes – Recommended action		Condensed state message active, when prompted, Err appears. When fault alarms exist, they are displayed here.
59	Auto-correction	Errors in the positioner's data section are detected detected by automatic monitoring and corrected automatically.
	Status classification	[No message]
	Recommended action	Automatic
60	Fatal error	Error in safety-relevant data that cannot be corrected automatically. Possible cause: EMC disturbances. The valve is moved to fail-safe position.
	Additional indication at the fault alarm contact.	
	Status classification	Maintenance alarm (cannot be classified)
	Recommended action	Reset over Code 36 – Std. Re-initialize the positioner.

Hardware error

Error codes – Recommended action		Condensed state message active, when prompted, Err appears. When fault alarms exist, they are displayed here.
62	x signal	Actuator's measured value recording failed. The conductive plastic element is defective. The device continues functioning in emergency mode but it must be replaced as quickly as possible. The emergency mode on the display is indicated by a blinking closed-loop operation icon and 4 dashes instead of the position reading. Note on the open-loop operation: <i>If the measuring system has failed, the positioner is still in a reliable state. The positioner switches to emergency mode where the position cannot be accurately controlled anymore. However, the positioner continues operation according to its set point so that the process remains in a safe state.</i>
	Status classification	[Maintenance demanded]
	Recommended action	Return positioner to SAMSON AG for repair.

Error codes – Recommended action		Condensed state message active, when prompted, Err appears. When fault alarms exist, they are displayed here.
63	w too low	The set point is considerably smaller than 4 mA (0 %); this happens when the positioner's power supply does not meet the standard requirements. This state is indicated on the positioner display by LOW blinking.
	Status classification	[No message]
	Recommended action	Check set point. If necessary, adjust the current source's lower limit so that no values lower than 4 mA can be applied.
64	i/p converter (y)	Current circuit of i/p converter interrupted.
	Status classification	Maintenance alarm (cannot be classified)
	Recommended action	Cannot be remedied. Return positioner to SAMSON AG for repair.

Error appendix

Error codes – Recommended action		Condensed state message active, when prompted, Err appears. When fault alarms exist, they are displayed here.
65	Hardware	Initialization key jammed (firmware version R 1.51 and higher)
	Additional indication at the fault alarm contact.	A hardware error has occurred. The positioner changes to the fail-safe position (SAFE).
	Status classification	[Maintenance alarm]
	Recommended action	Confirm error and return to automatic mode, or perform a reset and re-initialize the positioner. If this is not successful, return positioner to SAMSON AG for repair.
66	Data memory	No more data can be written to the memory, e.g. because written data deviate from read data. The valve moves to the fail-safe position.
	Additional indication at the fault alarm contact.	
	Status classification	Maintenance alarm (cannot be classified)
	Recommended action	Return positioner to SAMSON AG for repair.
67	Check calculation	Hardware controller monitored by test calculation.
	Additional indication at the fault alarm contact.	
	Status classification	[Maintenance alarm]
	Recommended action	Confirm error. If this is not possible, return positioner to SAMSON AG for repair.

Data error

Error codes – Recommended action		Condensed state message active, when prompted, <i>Err</i> appears. When fault alarms exist, they are displayed here.
68	Control parameters	Error in control parameters.
	Additional indication at the fault alarm contact.	
	Status classification	[Maintenance required]
	Recommended action	Confirm error, perform a reset and re-initialize the positioner.
69	Potentiometer parameters	Error in digital potentiometer parameters
	Additional indication at the fault alarm contact.	
	Status classification	[Maintenance required]
	Recommended action	Confirm error, perform a reset and re-initialize the positioner.
70	Calibration	Error in data from production calibration. The positioner continues operation with cold start values.
	Additional indication at the fault alarm contact.	
	Status classification	[Maintenance required]
	Recommended action	Return positioner to SAMSON AG for repair.
71	General parameters	Error in parameters not critical to control operation.
	Status classification	[Maintenance required]
	Recommended action	Confirm error. Check and, if necessary, change the settings of the require parameters.
73	Internal device error 1	Internal device error
	Status classification	[Maintenance required]
	Recommended action	Return positioner to SAMSON AG for repair.
74	HART® parameters	Error in parameters not critical to control operation.
	Status classification	[Maintenance required]
	Recommended action	Confirm error. Check and, if necessary, change the settings of the require parameters.

Error codes – Recommended action	Condensed state message active, when prompted, Err appears. When fault alarms exist, they are displayed here.	
76	No emergency mode	The travel measuring system of the positioner has a self-monitoring function (see Code 62). An emergency mode (open-loop control) is not available for certain actuators, such as double-acting actuators. In case of a travel sensing error, the positioner vents the output (Output 38) or A1 in double-acting actuators. During the initialization, the positioner automatically checks whether the actuator has such a function or not.
	Status classification	[No message]
	Recommended action	Merely information, confirm, if necessary. No further action required.
77	Software loading error	When the positioner starts operation for the first time after the current signal has been applied, it carries out a self-test (tESinG runs across the display). If the positioner loads the wrong software, the valve moves to the fail-safe position. It is not possible to make the valve leave this fail-safe position again.
	Status classification	Maintenance alarm (cannot be classified)
	Recommended action	Interrupt fieldbus signal and restart the positioner. If not successful, return positioner to SAMSON AG for repair.
78	Option parameters	Error in option parameters.
	Status classification	[Maintenance required]
	Recommended action	Return positioner to SAMSON AG for repair.

Diagnosis errors

Error codes – Recommended action		Condensed state message active, when prompted, Err appears. When fault alarms exist, they are displayed here.
79	Diagnostic messages	Messages generated by the extended diagnostics
	Status classification	Maintenance required (cannot be classified)
80	Diagnostic parameters	Error in parameters not critical to control operation.
	Status classification	Maintenance required (cannot be classified)
	Recommended action	Confirm error. Check and, if necessary, perform a new reference test.
81	Reference graphs	<p>Error occurred during plotting the reference graphs for drive signal y steady-state or drive signal y hysteresis.</p> <ul style="list-style-type: none"> • Reference test canceled • Reference line for drive signal y steady-state or drive signal y hysteresis was not adopted. <p>Error messages are not yet saved in a non-volatile memory. They cannot be reset.</p>
	Status classification	[No message]
	Recommended action	Check and, if necessary, perform a new reference test.

15 Dimensions in mm

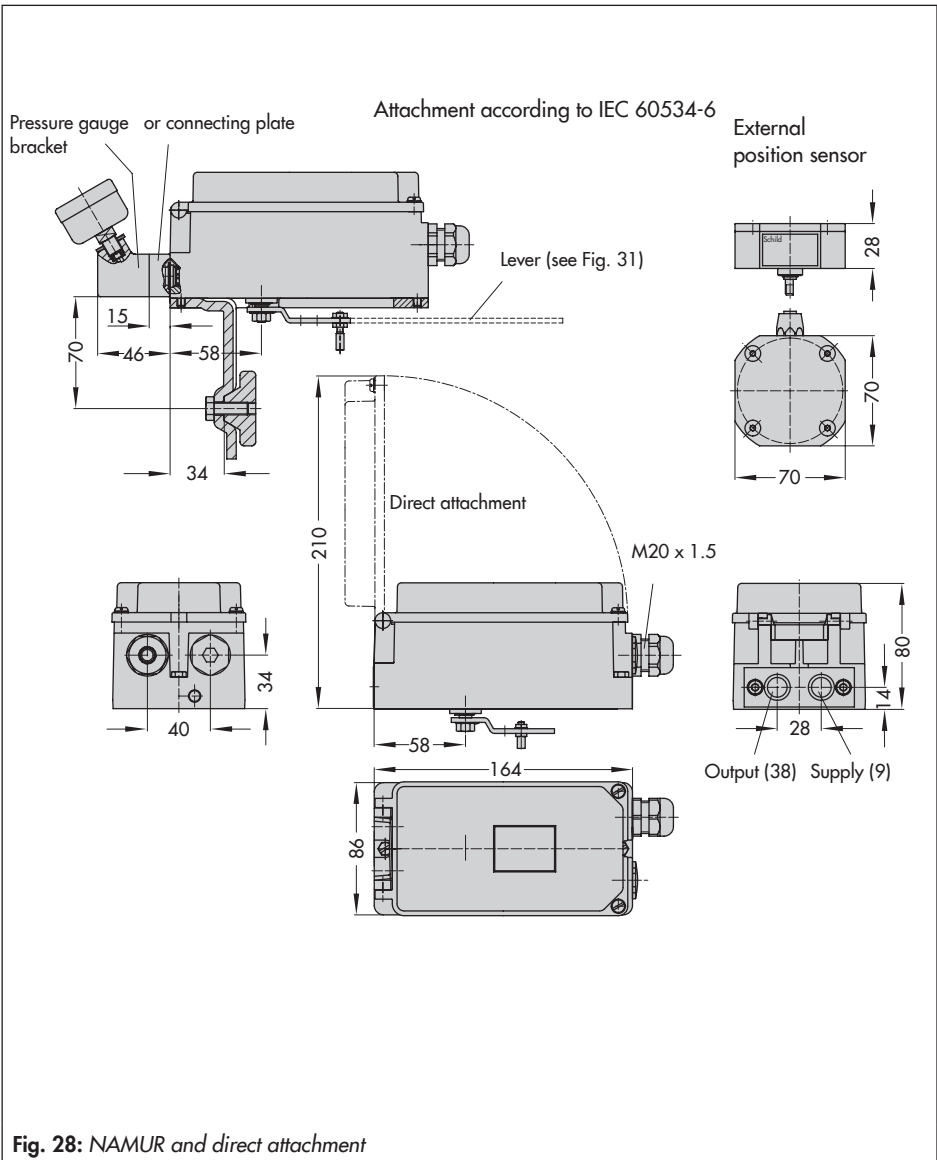
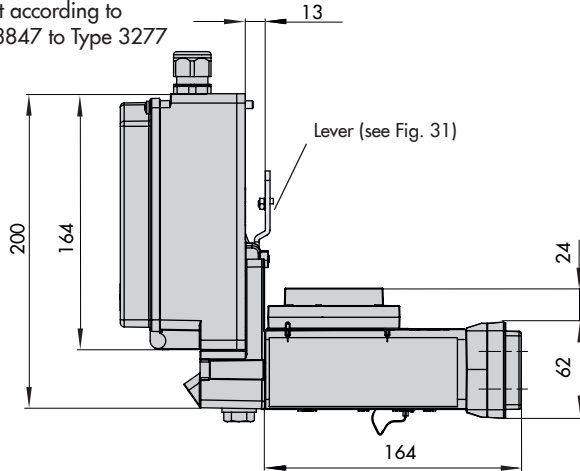

Fig. 28: NAMUR and direct attachment

Attachment according to
VDI/VDE 3847 to Type 3277



Attachment according to
VDI/VDE 3847 to a NAMUR
rib

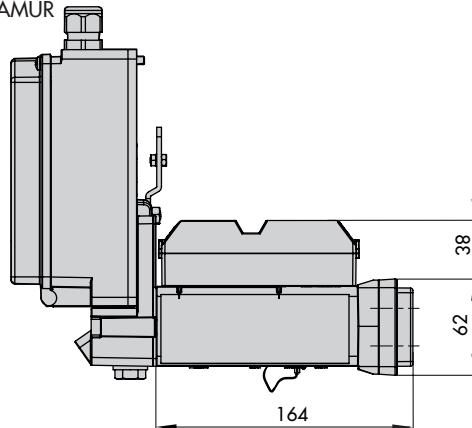
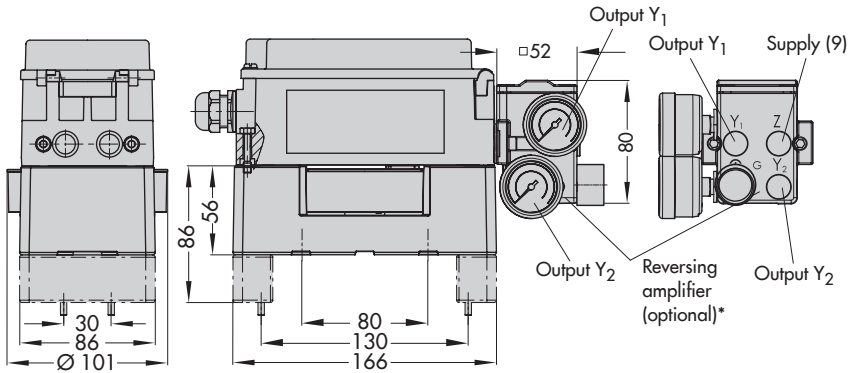
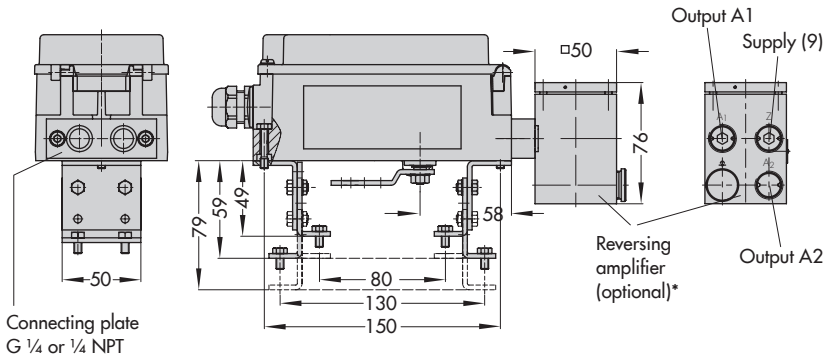

Fig. 29: Attachment according to VDI/VDE 3847

Heavy-duty version



Light version



* Reversing amplifier

- Type 3710 (see drawing of heavy-duty version for dimensions)
- 1079-1118/1079-1119, no longer available (see drawing of light version for dimensions)

Fig. 30: Attachment to rotary actuators acc. to VDI/VDE 3845 (Sept. 2010), fixing level 1, AA1 to AA4 size

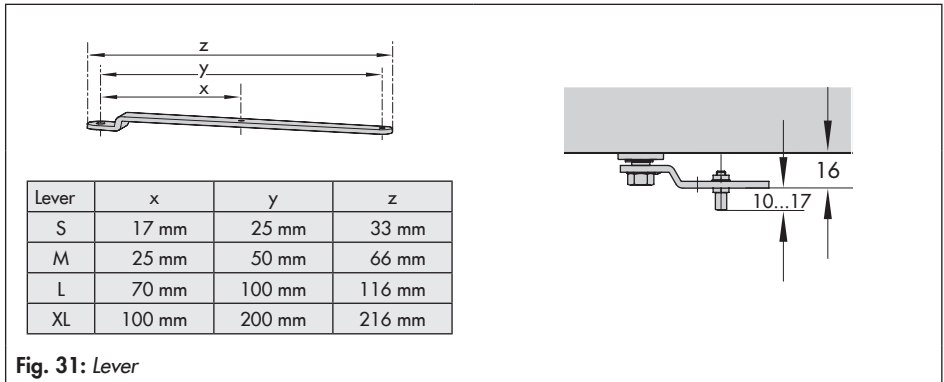

15.1 Fixing levels according to VDI/VDE 3845 (September 2010)

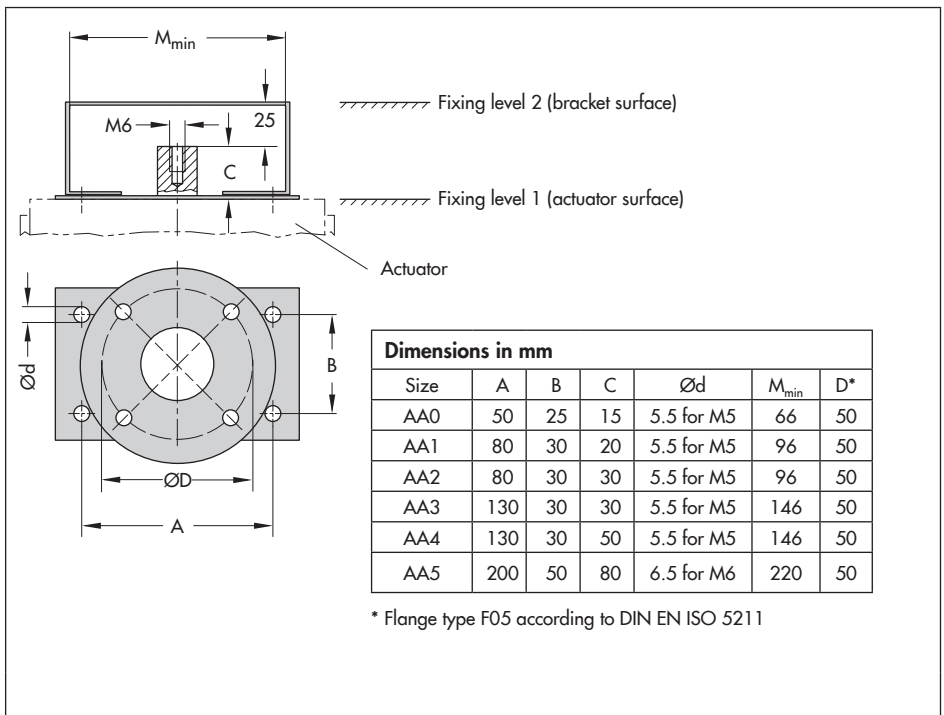

16 Valve characteristic selection

The characteristics that can be selected in Code 20 are shown in the following in graph form.



Note:

A characteristic can only be defined (user-defined characteristic) using a workstation/operating software (e.g. TROVIS-VIEW).

Linear (select characteristic: 0)

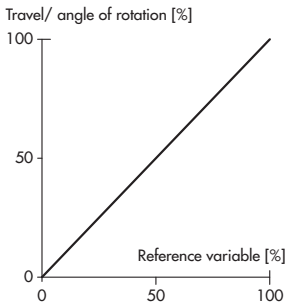

Equal percentage (select characteristic: 1)

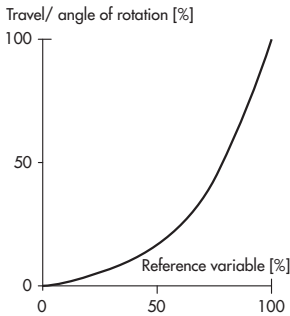

Reverse equal percentage (select characteristic: 2)

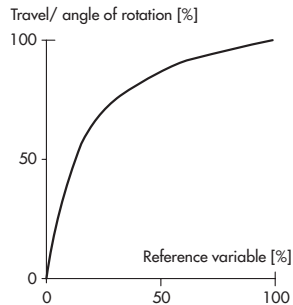

SAMSON butterfly valve linear (select characteristic: 3)

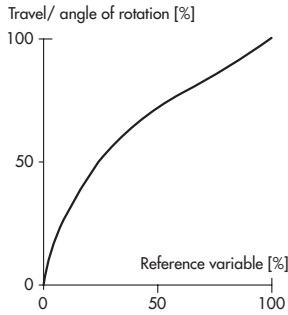

SAMSON butterfly valve equal percentage (select characteristic: 4)

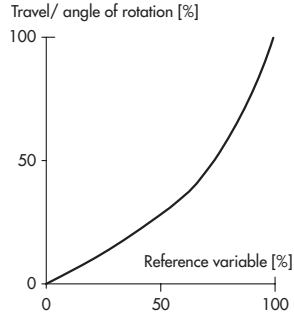

VETEC rotary plug valve linear (select characteristic: 5)

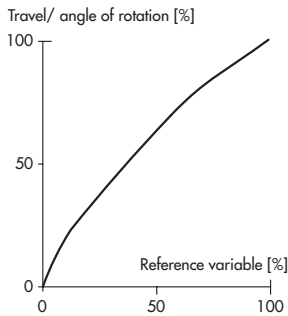

VETEC rotary plug valve equal percentage (select characteristic: 6)

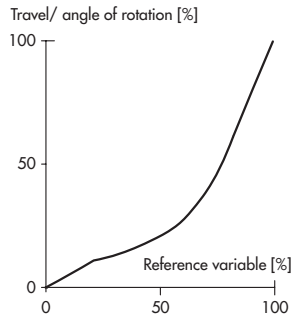

Segmented valve ball linear (select characteristic: 7)

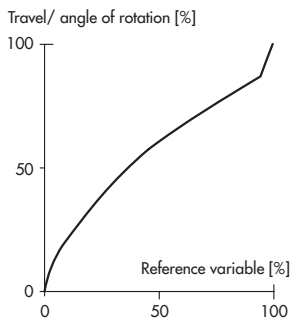

Segmented valve ball equal percentage (select characteristic: 8)

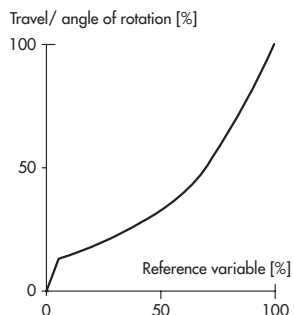

TRANSLATION

Offenbach, 2005-11-21

Your ref. 2005-11-08
 P. Opl

Our ref. 47900(0-9)010-0001/67325
 FG330hh-wah
 Contact
 H. Biele
 Tel. (069) 8386-246
 Fax (069) 8386-246
 gerhard.biele@vde.com

Test report for Information of the Applicant

Testing of the Degree of Protection on enclosures of Type 3730 and Type 3731 Positioners

This test report contains the result of a simple investigation carried out on the product submitted. A sample of this product was tested to find the accordance with the thereafter listed standards resp. parts of standards.

The test report does not entitle to a VDE certification mark and the "GS - geprüfte Sicherheit (test safety)" and does not refer to all VDE specifications applicable to the tested product.

This report may only be passed to a third party in its complete wording including this preamble and the date of issue.

Any publication or reproduction requires the prior written approval of the VDE Testing and Certification Institute.

1 Assignment

The samples described in 2 below were tested for compliance with the IP 66 degree of protection.

2 Samples

2.1 Type 3730 Positioner

2.2 Type 3731 Positioner

VDE VERBAND DER ELEKTROTECHNIK
 ELEKTROTECHNIK INFORMATIONSTECHNIK G.V

Testing and Certification Institute
 Merianstrasse 28
 D-63069 Offenbach

Prüfbericht VDE n. L.N. 6629 IP-Schwarztür. **E-mail:** vde-institut@vde.com

3 Basis of assessment

DIN EN 60529/VDE 0470 Part 1:2000-09
 Degree of protection provided by enclosures (IP Codes)
 German version EN 60529:1999+A1:2000

4 Execution of the tests

The dust test had already been carried out on the Type 3730 Positioner under the reference number: 47900(0-9)010-0001/32752 and on the Type 3731 Positioner under the reference number: 47900(0-9)010-0001/58985 with action as per category 1 at the connecting enclosures of the positioners and solenoid valves. The under pressure was 2 kPa and the test lasted 8 hours.

5 Test results

The testing of the samples described in 2 above yielded the following results:

Protecting against access to hazardous parts and against ingress of solid foreign objects according to DIN EN 60529/VDE 0470 Part 1:2000-09
IP6X satisfied

Protecting against ingress of water according to DIN EN 60529/VDE 0470 Part 1:2000-09
IPX6 satisfied

The positioner enclosures in the versions submitted meet the requirements of IP 66 degree of protection.

There was no ingress of either dust or water.

VDE Prüf und Zertifizierungsinstitut
 Fachgebiet FG33

(Signature)

(Signature)

Gerhard Biele

VDE VERBAND DER ELEKTROTECHNIK
 ELEKTROTECHNIK INFORMATIONSTECHNIK G.V

Testing and Certification Institute
 Merianstrasse 28
 D-63069 Offenbach

Prüfbericht VDE n. L.N. 6629 IP-Schwarztür. **E-mail:** vde-institut@vde.com



IECEx Certificate of Conformity

Certificate No.: **IECEx FTE 050008**
Issue No.: **2005-02-21**
Date of Issue: **2005-02-21**
Page 2 of 3

Manufacturer: **SAMSON AG Mess- und Regeltechnik**
D-60314 Frankfurt am Main
Germany

Manufacturing location(s):

This certificate is issued as verification that a sample(s), representative of production, was assessed and tested and found to comply with the IECEx Quality System requirements. This certificate is granted subject to the conditions as set out in IECEx Scheme Rules, IECEx.02 and Operational Documents as amended.

STANDARDS:

The electrical apparatus and any acceptable variations to it specified in the schedule of this certificate and the identified assessment, was found to comply with the following standards:

- IEC 60079-0 : 2000** Electrical apparatus for explosive gas atmospheres - Part 0: General requirements
- IEC 60079-11 : 1999** Electrical apparatus for explosive gas atmospheres - Part 11: Intrinsic safety ?
- IEC 60079-10 : 1999** Electrical apparatus for explosive gas atmospheres - Part 10: Intrinsic safety ?
- IEC 61241-1-1 : 1999** Electrical apparatus for use in the presence of combustible dust - Part 1-1: Electrical apparatus protected by enclosures and surface temperature limitation - Specification for apparatus

This certificate does not include compliance with electrical safety and performance requirements other than those expressly indicated in the Standards listed above.

TEST & ASSESSMENT REPORTS:

? Sample(s) of the equipment tested has successfully met the examination and assessment requirements as recorded in IECEx ATR:
File Reference: **BR2274**
DE/FTE/05-005



IECEx Certificate of Conformity

INTERNATIONAL ELECTROTECHNICAL COMMISSION IEC Certification Scheme for Explosive Atmospheres

for rules and details of the IECEx Scheme visit www.iecex.com

Certificate No.: **IECEx FTE 050008** Issue No.: **0**
Status: **Current** Page 1 of 3
Date of Issue: **2005-02-21**

Applicant: **SAMSON AG Mess- und Regeltechnik**
D-60314 Frankfurt am Main
Germany

Electrical Apparatus: **HART capable positioner type 3730-31 -**
Optional accessory:

Type of Protection: **General Requirements, Intrinsic Safety, Protection by Enclosure**

Marking: **Ex ia IIC T80/1574**
IP 64 and IP 65 T 80 °C

Approved for Issue on Behalf of the IECEx
Certification Body:

Position: **Dr.-Ing. Ulrich Johannmeyer**
Department Head "Intrinsic Safety and Safety of Systems"

Signature: _____
(as per rules necessary)

Date: _____

1. This certificate and schedule may only be reproduced in full.
2. This certificate is not transferable and remains the property of the issuing body.
3. The Status and authenticity of this certificate may be verified by visiting the Official IECEx Website.

Certificate issued by:

**Physikalisch-Technische
Bundesanstalt (PTB)**

Charitéallee 100
38110 Braunschweig
Germany





IECEx Certificate of Conformity

Certificate No.:

IECEX PTE 054008

Date of Issue:

2005-02-21

Issue No.: 0

Page 3 of 3

Schedule

EQUIPMENT:

Equipment and systems covered by this certificate are as follows:

General description: The Model 3730-31 HART® capable Positioner is a single- or double-acting positioner with self-balancing type and 4 digits self-actuator to fit in attach rod valve or actuator respectively. The positioner serves for matching valve stem positions (controlled variable X) with the control signal (reference variable W) in the 4-20mA range. The positioner is available in two versions: NAMUR- and non-NAMUR-type. The positioner is available for rotary and linear actuators. Features: Simple attachment to current loop and rotary actuators with interface for SAISON; direct attachment; NAMUR-rob. attachment to rod type valve acc. to IEC 60534-6-1. Any mounting position of the positioner. NAMUR-rob. attachment to rod type valve acc. to IEC 60534-6-1. Any mounting position of the positioner. Output: external displacement transducer and serial interface. In the ex version the fault alarm output, the software proximity switches and the inductive proximity switch are analysed by a NAMUR-switching amplifier according to EN 62277.

CONDITIONS OF CERTIFICATION: NO

Annex: 3730-31_Electrical data.pdf; 3730-31_Type code.pdf



(1) EU-TYPE-EXAMINATION CERTIFICATE

(Translation)

- (2) Equipment or Protective Systems Intended for Use in Potentially Explosive Atmospheres - Directive 2014/34/EU
- (3) EU-Type Examination Certificate Number: **PTB 02 ATEX 2174**
- (4) Product: **HART capable positioner types 3730-31... and 3730-35...**
- (5) Manufacturer: **SAMSON AG Mess- und Regeltechnik**
- (6) Address: **Wilhelmstraße 3, 60314 Frankfurt, Deutschland**
- (7) This product and any acceptable variation thereto is specified in the schedule to this certificate and the documents therein referred to.
- (8) The Physikalisch-Technische Bundesanstalt, notified body No. 0102 in accordance with Article 17 of the Directive 2014/34/EU of the European Parliament and of the Council, dated 28 February 2014, certifies that this product has been found to comply with the Essential Health and Safety Requirements relating to the design and construction of products intended for use in potentially explosive atmospheres, given in Article 18 of the Directive.
- (9) The examination and test results are recorded in the confidential Test Report PTB Ex 16-25137.
- (10) Compliance with the Essential Health and Safety Requirements has been assured by compliance with:
EN 60079-0:2012/AM1:2013 EN 60079-11:2012 EN 60079-31:2014
- (11) If the sign "X" is placed after the certificate number, it indicates that the product is subject to the Specific Conditions of Use specified in the schedule to this certificate.
- (12) This EU-Type Examination Certificate relates only to the design and construction of the specified product in accordance to the Directive 2014/34/EU. Further requirements of the Directive apply to the manufacturing process and supply of this product. These are not covered by this certificate.

II 2 G Ex ia IIC T6...T4 Gb resp. Ex ia IIC T80 °C Db and II 2 D Ex ib IIC T80°C Db Braunschweig, June 26, 2016

Konformitätsbewertungsstelle, Sektor Explosionsschutz
On behalf of PTB
Dr.-Ing. U. Gering
Regierungsdrucker

sheet 1/6

EU-Type Examination Certificate without signature and official stamp shall not be used. The certificate may be consulted only without alteration. Extracts or alterations are subject to approval by the Physikalisch-Technische Bundesanstalt. In case of dispute, the German text shall prevail.



SCHEDULE

- (13)
- (14) **EU-Type Examination Certificate Number PTB 02 ATEX 2174, Issue: 01**

(15) Description of Product

The HART capable positioner type 3730-31... and 3730-35... is a communication capable, single respectively double operating positioner for the attachment to all common lift or elevation actuators. It is intended to assign the valve position to an actuating signal. The communication is carried out by using SSP and HART protocols. As a pneumatic auxiliary power non-combustible media are used.

The operation takes place inside or outside hazardous areas.

In the future, the HART capable positioner type 3730-31... and 3730-35... may also be manufactured and operated according to the test documents listed in the test report.

The thermal and electrical maximum values are presented in summary.

For relationship between temperature class and permissible ranges of the ambient temperature, reference is made to the following table:

Gas- or dust group	Temperature class	Permissible range of the ambient temperature
IIC	T6	-55 °C ... 60 °C
	T5	-55 °C ... 70 °C
IIIC	T4	-55 °C ... 80 °C
	-	-55 °C ... 80 °C

Electrical data

Type 3730-35

U_n = 28 V
P_n = 1 W

Type 3730-31

Signal circuit:type of protection intrinsic Safety Ex ia IIC/IIC only for connection to a certified intrinsically safe circuit (terminals 11/12)

Maximum values:

I_n = 28 V
I_n = 115 mA
P_n = 1 W
L_n negligibly low
C_n = 35 nF

sheet 2/6

EU-Type Examination Certificate without signature and official stamp shall not be used. The certificate may be consulted only without alteration. Extracts or alterations are subject to approval by the Physikalisch-Technische Bundesanstalt. In case of dispute, the German text shall prevail.

SCHEDULE TO EU-TYPE EXAMINATION CERTIFICATE PTB 02 ATEX 2174 , Issue: 01

Position indicatortype of protection Intrinsic Safety Ex ia IIC/IIC
 (terminals 31/32) only for connection to a certified intrinsically safe circuit

Maximum values:
 $U_i = 28$ V
 $I_i = 145$ mA
 $P_i = 1$ W

L_i negligibly low
 $C_i = 5.3$ nF

Type 3730-31.....1.....type of protection Intrinsic Safety Ex ia IIC/IIC
 (Structure-borne sound sensor) only for connection to a certified intrinsically safe circuit

Maximum values:
 $U_i = 30$ V
 $I_i = 100$ mA
 L_i negligibly low
 $C_i = 5.3$ nF

Type 3730-31.....1.....type of protection Intrinsic Safety Ex ia IIC/IIC
 (Binary sensor) only for connection to a certified intrinsically safe circuit

Maximum values:
 $U_i = 30$ V
 $I_i = 100$ mA
 $P_i = 250$ mW
 L_i negligibly low
 $C_i = 56.3$ nF

Limit contacts, switchingtype of protection Intrinsic Safety Ex ia IIC/IIC
 (terminals 41/42, 51/52) only for connection to a certified intrinsically safe circuit

Maximum values:
 $U_i = 20$ V
 $I_i = 60$ mA
 $P_i = 250$ mW
 L_i negligibly low
 $C_i = 5.3$ nF

sheet 3/6

EU-Type Examination Certificates without signature and official stamp shall not be valid. The certificates may be cancelled only without alteration. Errata or amendments shall appear in the next issue of the certificate. In case of dispute, the German text shall prevail.

Physikalisch-Technische Bundesanstalt • Bundesallee 100 • 38116 Braunschweig • GERMANY

SCHEDULE TO EU-TYPE EXAMINATION CERTIFICATE PTB 02 ATEX 2174 , Issue: 01

Limit contact, inductivetype of protection Intrinsic Safety Ex ia IIC/IIC
 (terminals 41/42) only for connection to a certified intrinsically safe circuit

Maximum values:
 $U_i = 16$ V
 $I_i = 52$ mA
 $P_i = 169$ mW
 $L_i = 100$ μ H
 $C_i = 30$ nF

or

$U_i = 16$ V
 $I_i = 25$ mA
 $P_i = 64$ mW
 $L_i = 100$ μ H
 $C_i = 30$ nF

For relationship between temperature class, permissible ranges of the ambient temperature, maximum short-circuit currents and maximum power for analyzing units, reference is made to the table:

Temperature class	Permissible range of the ambient temperature	I_{sc} / P_{sc}
T6	-55 °C ... 45 °C	
T5	-55 °C ... 60 °C	52 mA / 169 mW
T4	-55 °C ... 75 °C	
T6	-55 °C ... 60 °C	
T5	-55 °C ... 80 °C	25 mA / 64 mW
T4	-55 °C ... 80 °C	

Forced ventingtype of protection Intrinsic Safety Ex ia IIC/IIC
 (terminals 61/62) only for connection to a certified intrinsically safe circuit

Maximum values:
 $U_i = 28$ V
 $I_i = 115$ mA
 L_i negligibly low
 $C_i = 5.3$ nF

sheet 4/6

EU-Type Examination Certificates without signature and official stamp shall not be valid. The certificates may be cancelled only without alteration. Errata or amendments shall appear in the next issue of the certificate. In case of dispute, the German text shall prevail.

Physikalisch-Technische Bundesanstalt • Bundesallee 100 • 38116 Braunschweig • GERMANY



SCHEDULE TO EU-TYPE EXAMINATION CERTIFICATE PTB 02 ATEX 2174, Issue: 01

Fault signal output type of protection Intrinsic Safety Ex ia IIC/IIC
(terminals 63/64) only for connection to a certified intrinsically safe circuit

Maximum values:

- U_i = 20 V
- I_i = 60 mA
- P_i = 250 mW
- L_i negligibly low
- C_i = 5.3 nF

Serial interface type of protection Intrinsic Safety Ex ia IIC/IIC
(Programming socket)

Maximum values:

- U_i = 7.88 V
- I_i = 61.8 mA
- P_i = 120 mW
- linear characteristic
- L_i = 10 mH
- C_i = 0.65 µF

or

only for connection to a certified intrinsically safe circuit

Maximum values:

- U_i = 16 V
- I_i = 25 mA
- P_i = 64 mW
- L_i negligibly low
- C_i negligibly low

When intrinsically safe circuits are interconnected the rules for the interconnection of intrinsically safe circuits shall be observed.

External position sensor type of protection Intrinsic Safety Ex ia IIC/IIC
(Analog-PCB, pins p6, p10, p11)

Maximum values:

- U_i = 7.88 V
- I_i = 61.8 mA
- P_i = 120 mW
- linear characteristic
- L_i = 10 mH
- C_i = 0.66 µF
- L_s = 370 nH
- C_s = 730 pF

sheet 5/6

EU-Type Examination Certificates without signature and official stamp shall not be valid. The certificates may be cancelled only in case of falsification, fraud or other irregularities. In case of dispute, the German text shall prevail.



SCHEDULE TO EU-TYPE EXAMINATION CERTIFICATE PTB 02 ATEX 2174, Issue: 01

Changes:

The changes concern the update of the applied standards, the adding of another type notation for dust ignition protection by enclosure, the implementation of dust ignition protection by enclosure, the application of alternative gasket material of the enclosure. Except the application of alternative enclosures, no other technical changes were made to the equipment.

(16) Test Report PTB Ex16-25137

(17) Specific conditions of use

none

(18) Essential health and safety requirements

Met by compliance with the harmonized standards mentioned under (9).

According to Article 41 of Directive 2014/34/EU, EC-type examination certificates which have been issued prior to the date of coming into force of Directive 2014/34/EU (April 20, 2016) shall remain valid until the date of expiry of the certificate with Directive 2014/34/EU. By permission of the European Commission supplements to such EC-type examination certificates and new issues of such certificates may continue to hold the original certificate number issued before April 20, 2016.

Konformitätsbewertungsstelle, Sektor Explosionschutz
Braunschweig, June 29, 2026

On behalf of PTB:



Dr.-Ing. U. Gernert
Regierungsdirektor

sheet 6/6

EU-Type Examination Certificates without signature and official stamp shall not be valid. The certificates may be cancelled only in case of falsification, fraud or other irregularities. In case of dispute, the German text shall prevail.



(1) **CONFORMITY STATEMENT**
(Translation)

- (2) Equipment and Protective Systems Intended for Use in Potentially Explosive Atmospheres - Directive 2014/34/EU
- (3) Test Certificate Number: **PTB 03 ATEX 2180 X**
- (4) Product: HART capable positioner Typ 3730-38..
- (5) Manufacturer: SAMSON AG Mess- und Regeltechnik
- (6) Address: Weimüllerstraße 3, 80314 Frankfurt, Deutschland
- (7) This product and any acceptable variation thereto are specified in the schedule to this certificate and the documents therein referred to.
- (8) The Physikalisch-Technische Bundesanstalt, notified body No. 0102, in accordance with Article 17 of the European Union Directive 2014/34/EU of 26 February 2014, certifies that this product has been found to comply with the Essential Health and Safety Requirements of the design and construction of products intended for use in potentially explosive atmospheres, given in Annex II to the Directive.
- (9) The examination and test results are recorded in the confidential test report PTB Ex 16-25138. Compliance with the Essential Health and Safety Requirements has been assumed by compliance with: **EN 60079-0:2012/AM1:2013 EN 60079-15:2010 EN 60079-31:2014**
- (10) If the sign "X" is placed after the certificate number, it indicates that the product is subject to special conditions for safe use specified in the schedule to this certificate.
- (11) This Conformity Statement relates only to the design and construction of the specified product in its original active state/IEC. Further requirements of this Directive apply to the manufacture and supply of this product.
- (12) The marking of the product shall include the following:

II 3 G Ex nA IIC T8 Gc und
II 3 D Ex to IIIC T80 °C Dc

Konformitätsbewertungsstelle / Sektor Explosionschutz Braunschweig, June 30, 2016

On behalf of PTB:

Dr.-Ing U. Gerber
Regelungsinspektor

Sheet 1/4

Conformity Statements without signature and official stamp shall not be valid. The certificates may be downloaded only without alteration. Extracts or alterations are subject to approval by the Physikalisch-Technische Bundesanstalt. In case of dispute, the German text shall prevail.

Physikalisch-Technische Bundesanstalt • Bundesallee 100 • 38116 Braunschweig • GERMANY



SCHEDULE

- (13) **DESCRIPTION OF THE PRODUCT**
- (14) **CONFORMITY STATEMENT PTB 03 ATEX 2180 X, Ausgabe: 01**
- (15) **Description of the product**
- The HART capable positioner type 3730-38.. is a communication capable, single respectively double operating positioner for the attachment to all common lift or slewing-motion actuators. It is intended to assign the valve position to an actuating signal. The communication is carried out by using SSP and HART protocols. As a pneumatic auxiliary power non-combustible media are used.
- The operation takes place inside or outside hazardous areas.
- In the future the HART capable positioner type 3730-38.. may also be manufactured and operated according to the test documents listed in the test report.

The thermal and electrical maximum values are presented in summary.

For relationship between temperature class and permissible ranges of the ambient temperature, reference is made to the following table:

Gas or dust group	Temperature class	Permissible range of the ambient temperature
IIC	T8	-55 °C ... 60 °C
	T5	-55 °C ... 70 °C
IIIC	T4	-55 °C ... 80 °C
	-	-55 °C ... 80 °C

Electrical data

Signal circuit:
(Terminals 11/12)..... Nominal signal: 4 ... 20 mA
Rated voltage: 32 V DC ... 85 V DC

Position indicator:
(Terminals 31/32)..... Output signal: 4 ... 20 mA
Rated voltage: 32 V DC ... 85 V DC

Sensor connection
(Terminals 31/32)..... Inner capacitance 1,4 nF

Sheet 2/4

Conformity Statements without signature and official stamp shall not be valid. The certificates may be downloaded only without alteration. Extracts or alterations are subject to approval by the Physikalisch-Technische Bundesanstalt. In case of dispute, the German text shall prevail.

Physikalisch-Technische Bundesanstalt • Bundesallee 100 • 38116 Braunschweig • GERMANY

SCHEDULE TO EU-TYPE EXAMINATION CERTIFICATE PTB 03 ATEX 2180 X, Issue: 01

Binary input: (Terminals 31/32).....	Nominal signal: 30 V DC Rated voltage: 32 V DC ... 85 V DC
Limit contact, inductive (Terminals 41/42).....	Nominal signal: 8 V DC, 8 mA
Limit contacts, software (Terminals 41/42).....	Nominal signal: 8 V DC, 8 mA
Forced venting (Terminals 81/82).....	Nominal signal: 6 ... 24 V DC Rated voltage: 32 V DC ... 85 V DC
Fault signal output (Terminals 83/84).....	Nominal signal: 8 V DC, 8 mA
External position sensor: (Analog board Pins p9, p10, p11).....	Nominal signal: potentiometer

Changes

The changes concern the update of the applied standards, the adding of another type notation for dust ignition protection by enclosure, the discontinue of the intrinsically safe variant and the application of alternative gasket material of the enclosure.

(16) Test report PTB Ex 16-25138
(17) Specific conditions of use

A fuse according to IEC 60127-2/II, 250 V F respectively IEC 60127-2/VI, 250 V T with a maximum nominal fuse current of $I_n \leq 63$ mA shall be connected in series to the signal circuit (terminals 11/12).

If the position indicator circuit is connected to a circuit of type of protection Ex nA IIC/IIC a fuse according to IEC 60127-2/VI, 250 V T with a maximum nominal fuse current of $I_n \leq 40$ mA shall be connected in series. This fuse shall be arranged outside of the hazardous area.

A fuse according to IEC 60127-2/II, 250 V F respectively IEC 60127-2/VI, 250 V T with a maximum nominal fuse current of $I_n \leq 40$ mA shall be connected in series to the program interface adapter in the connection of Voc.

The program interface adapter shall be arranged outside the hazardous area.

The connection of the wires has to be made in a way that the connection is free of tensile and torsional stress.

Connection, disconnection and switching of energized circuits is only permitted during installation, maintenance or repair.

Sheet 3/4

Conformity Certificates without signatures and official stamps shall not be valid. The certificates may be cancelled only without alteration. Extracts or alterations are subject to approval by the Physikalisch-Technische Bundesanstalt. In case of dispute, the German text shall prevail.

Physikalisch-Technische Bundesanstalt • Bundesallee 100 • 38116 Braunschweig • GERMANY

SCHEDULE TO EU-TYPE EXAMINATION CERTIFICATE PTB 03 ATEX 2180 X, Issue: 01
(18) Essential health and safety requirements

Met by compliance with the aforementioned standards.

According to Article 41 of Directive 2014/34/EU, Conformity Statements which have been issued according to Directive 94/9/EC (ATEX) shall be considered as if they were issued in compliance with Directive 2014/34/EU. By permission of the European Commission supplements to such Conformity Statements and new issues of such certificates may continue to hold the original certificate number issued before April 20, 2016.

 Konformitätsbewertungsstelle, Sektor Explosionsschutz
 On behalf of PTB Braunschweig, June 30, 2016

Sheet 4/4

Conformity Certificates without signatures and official stamps shall not be valid. The certificates may be cancelled only without alteration. Extracts or alterations are subject to approval by the Physikalisch-Technische Bundesanstalt. In case of dispute, the German text shall prevail.

Physikalisch-Technische Bundesanstalt • Bundesallee 100 • 38116 Braunschweig • GERMANY

Installation Manual for apparatus certified by CSA for use in hazardous locations.

Electrical rating of intrinsically safe apparatus and apparatus for installation in hazardous locations.

Table 1: Maximum values

Circuit No.	Control signal	Position Indicator (Binary Input) or Solenoid valve [Leakage detection]	Forced venting function Solenoid valve	Limit switches		Fault signal
				Inductive	software	
1	11 / 12	2	5	3 and 4	3 and 4	6
Terminal No.	31 / 32	41 / 42 and 51 / 52	81 / 82	41 / 42 and 51 / 52	41 / 42 and 51 / 52	83 / 84
U _I or V _{max}	28V	28V	28V	18V	20V	20V
I _{or} I _{max}	115mA	115mA [100mA]	115mA	2952 mA	60mA	60mA
P _{or} P _{max}	1W	1W [100mW]	500mW	84189mW	250mW	250mW
C _i	35nF	6.3nF (6.3nF) [3.3nF]	5.3nF	60nF	13.4nF	13.4nF
L _i	0µH	0µH	0µH	100µH	0µH	0µH

Circuit	Serial interface BU		External position sensor	
	Connector	Analog pcb, pin p9, p10, p11	U _{or} V _{cc}	I _{or} I _{sc}
U _I or V _{max}	18V	U _{or} V _{cc}	7.88V	7.88V
I _{or} I _{max}	25mA	I _{or} I _{sc}	61.9mA	61mA
P _{or} P _{max}	64mW	P ₀	120mW	120mW
C _i	0nF	C ₀	0.66µF	C ₀ =73nF
L _i	0µH	L ₀	10nH	L ₀ =370µH

Notes: Entity parameters must meet the following requirements:

U_I or V_{cc} or V_I ≤ U_I or V_{max} / I_{or} I_{sc} or I_{sc} ≤ I_{or} I_{max} / P_{or} or P_{max} ≤ P_{or} or P_{max}

C_i ≥ C₀ + C_{able} and L₀ ≥ L_i + L_{able}

Revision Control Number: 1 / Jun. 2008

Addendum to EB 8384-3EN

Table 2: CSA/FM – certified barrier parameters of circuit 2 and 5

Barrier	Supply barrier				Evaluation barrier			
	V _{cc}	R _{min}	I _{sc}	P _{max}	V _{oc}	R _{min}	I _{sc}	#
circuit 2	±28V	≥200Ω	≤115mA	≤1W	±28V	≥28V	0mA	0mA
circuit 5	±28V	≥282Ω	≤115mA	≤500mW	±28V	≥28V	0mA	0mA

Table 3: The correlation between temperature classification and permissible ambient temperature ranges is shown in the table below:

Temperature class	Permissible ambient temperature range
T6	-40°C ... 60°C
T5	-40°C ... 70°C
T4	-40°C ... 80°C

Table 4: For the Model 3720 – 331, Positioner the correlation between temperature classification, permissible ambient temperature ranges and maximum short-circuit current is shown in the table below:

Temperature class	Permissible ambient temperature range	Maximum short-circuit current
T6	-40°C ... 45°C	52mA
T5	-40°C ... 60°C	52mA
T4	-40°C ... 75°C	52mA
T6	-40°C ... 60°C	25mA
T5	-40°C ... 80°C	25mA
T4	-40°C ... 80°C	25mA

Revision Control Number: 1 / Jun. 2008

Addendum to EB 8384-3EN

Intrinsically safe if installed as specified in manufacturer's installation manual.

CSA-certified for hazardous locations

Ex to IIC T6: Class I, Zone 0
 Class I, Div. 1, Groups A, B, C, D,
 Class II Div. 1, Groups E, F + G, Class III.

Type 4 Enclosure

Notes:

- 1.) The apparatus may be installed in intrinsically safe circuits only when used in conjunction with CSA certified apparatus. For maximum value of U or V_{max}: II or I max; P; or P_{max}; C and U of the various apparatus see Table 1 on page 1.
- 2.) For barrier selection see Table 2 on page 2.
- 3.) The installation must be in accordance with the C. E. C. Part 1.
- 4.) Use only supply wires suitable for 5°C above surrounding temperature.
- 5.) For CSA Certification, Safety Barrier must be CSA Certified and installed in accordance with C.E.C. Part. 1. Each pair of I.S. wires must be protected by a shield that is grounded at the I.S. Ground. The shield must extend as close to the terminals as possible.

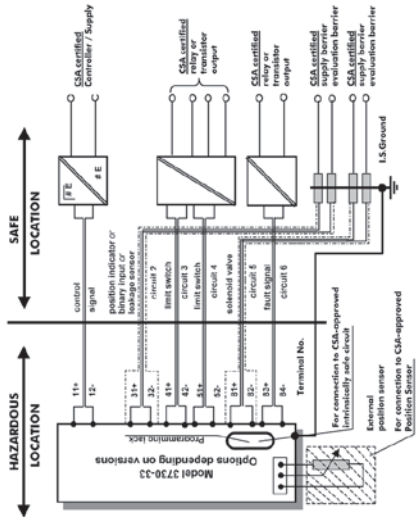

For the permissible maximum values for the intrinsically safe circuits 1,3,4 and 6 see Table 1
 For the permissible barrier parameters for the circuits 2 and 5 see Table 2
 Cable entry M 20 x 1.5 or metal conduit according to drawing No. 1050 - 0539 T
 or 1050 - 0540 T

Revision Control Number: 1/ Jun. 2008

Addendum to EB 8384-3EN

On interconnection to form ground-free signal circuits, only evaluation barriers must be installed in the return line. Correct polarity must be ensured.

Circuit diagram of a ground-free signal circuit.
 (position indicator and forced venting function)

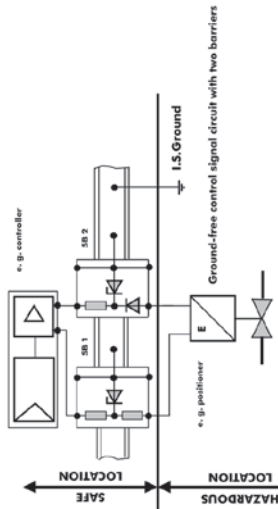

In grounded signal circuits with only one barrier, the return line must be grounded or included in the potential equalization network of the system.

Circuit diagram of a grounded signal circuit
 (position indicator and forced venting function)

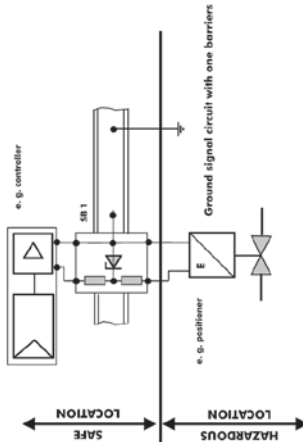

Revision Control Number: 1/ Jun. 2008

Addendum to EB 8384-3EN

C5A- certified for hazardous locations
 Class I, Zone 2, Groups A, B, C, D,
 Class I, Division 2, Groups E, F + G; Class III,
 Class II, Groups E, F + G; Class III.

Type 4 Enclosure

Type 4 Enclosure

HART-capable positioner with position indicator, forced venting function (solenoid valve), fault signal and limit switches.

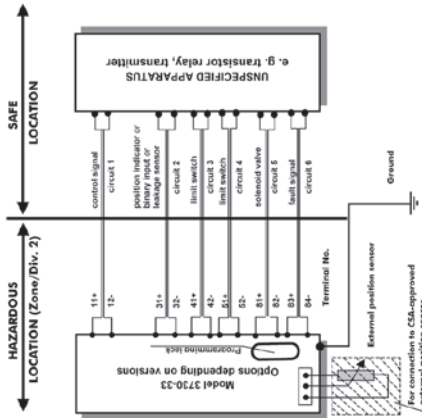

Notes:

- 1.) The installation must be in accordance with the Canadian Electrical Code, Part 1
- 2.) For the maximum values for the individual circuits see Table 1 and 2.
- 3.) Cable entry only rigid metal conduit according to drawing No. 1050-05539 F and 1050-05401

Revision Control Number: 1/ Jun. 2008

Addendum to EB 8384-3EN

Installation drawing Control Relay KHA5-OTI/Ex2, KHA6-OTI/Ex1 or
 KHA6-OTI/Ex2 with Model SJ-I-N Proximity Sensors

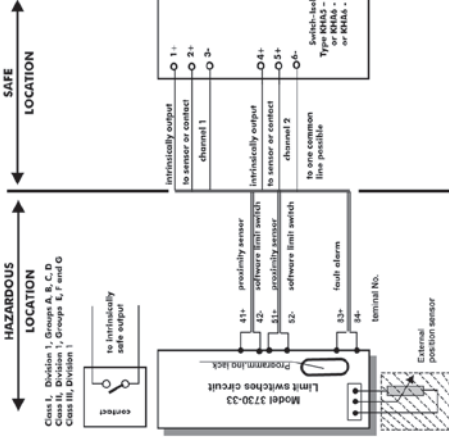

maximum capacitance of each inductive sensor 60nF
 maximum inductance of each inductive sensor 250µH

The table series indicates the maximum capacitance and inductance of shielded wiring that be connected to the following maximum values

Control Relay Terminal No.	Groups	L [m]	C [µF]	VOC [V]	IOC [mA]
1-3; 2-3 4-6; 5-4	A + B	0,4-0	1,27	←	←
	C	2,99	3,22	12,9	19,8
	D	7,44	10,2	→	→

Each pair of I.S. wires must be protected by a shield that is grounded at the I.S. Ground. The shield must extend as close to the terminals as possible. Install per C.E.C. Part 1.

Revision Control Number: 1/ Jun. 2008

Addendum to EB 8384-3EN

Installation Manual for apparatus approved by FM for use in hazardous locations.
Electrical rating of intrinsically safe apparatus and apparatus for installation in hazardous locations.

Table 1: Maximum values

Circuit No.	Control signal	Position indicator or (Binary Input) or [Leakage detection]	Forced venting function Solenoid valve	Limit switches		Fault signal
				Inductive	software	
1	11/12	31/32	81/82	3 and 4	3 and 4	6
Terminal No.	28V	28V	28V	41/42 and 51/52	41/42 and 51/52	83/84
U _I or V _{max}	28V	28V	28V	16V	20V	20V
I _I or I _{max}	115mA	115mA [100mA]	115mA	25/52 mA	60mA	60mA
P _I or P _{max}	1W	1W	500mW	84/169mW	250mW	250mW
C _I	35nF	5.3nF [63.3nF] [5.3nF]	5.3nF	60nF	13.4nF	13.4nF
L _I	0µH	0µH	0µH	100µH	0µH	0µH

Terminal	Serial interface BU		External position sensor	
	Connector	Analog pcb: pin p9, p10, p11	U _I or V _{cc}	U _I or V _{cc}
U _I or V _{max}	16V	U _I or V _{cc}	7.68V	7.68V
I _I or I _{max}	25mA	I _I or I _{cc}	81.8mA	I _I or I _{cc}
P _I or P _{max}	64mW	P _I	120mW	P _I
C _I	0nF	C _I	0.65µF	C _I
L _I	0µH	L _I	10mH	L _I
			0.86µF	C _I =73nF
			10mH	L _I =370µH

Notes: Entry parameters shall meet the following requirements:

U_I or V_{cc} or V_I ≤ U_I or V_{max} / I_I or I_{cc} or I_I ≤ I_I or I_{max} / P_I or P_{max} ≤ P_I or P_{max}
C_I ≥ C_I + Cable and L_I ≥ L_I + Lead

Revision Control Number: 3 Jun. 08

Addendum to EB 8384-3EN

Table 2: FM / CSA – approved barrier parameters of circuit 2 and 5

Barrier	Supply barrier			Evaluation barrier		
	V _{oc}	R _{min}	I _{sc}	V _{oc}	R _{min}	I _{sc}
circuit 2	528V	≥198Ω	≤115mA	528V	#	0mA
circuit 5	528V	≥392Ω	≤115mA	528V	#	0mA

Table 3: The correlation between temperature classification and permissible ambient temperature ranges is shown in the table below:

Temperature class	Permissible ambient temperature range
T6	60°C
T5	-40°C ≤ t _a ≤ 70°C
T4	80°C

Table 4: For the Model 3730 – 331 . . . Positioner the correlation between temperature classification, permissible ambient temperature ranges and maximum short-circuit current is shown in the table below:

Temperature class	Permissible ambient temperature range	Maximum short-circuit current
T6	45°C	52mA
T5	-40°C ≤ t _a ≤ 60°C	52mA
T4	75°C	25mA
T6	60°C	25mA
T5	-40°C ≤ t _a ≤ 80°C	25mA
T4	80°C	

Revision Control Number: 3 Jun. 08

Addendum to EB 8384-3EN

Intrinsically safe if installed as specified in manufacturer's installation manual.

FM-approved for hazardous locations

Class I, Zone 0 A Ex ia IIC T4;
Class I, II, III, Div. 1, Groups A, B, C, D, E, F + G;

NEMA 4X

Notes:

- 1.) The apparatus may be installed in intrinsically safe circuits only when used in conjunction with FM/CSA approved apparatus. For maximum values of U_i or V_{max} : II or V_{max} : II or I_{max} : PI or P_{max} : C and U_i of the various apparatus see Table 1 on page 7.
- 2.) For barrier selection see Table 2 on page 8.
- 3.) The installation shall be in accordance with the National Electrical Code ANSI/NFPA 70 and ANSI/ISA RP 12.06.01.
- 4.) Use only supply wires suitable for 5°C above surrounding temperature.

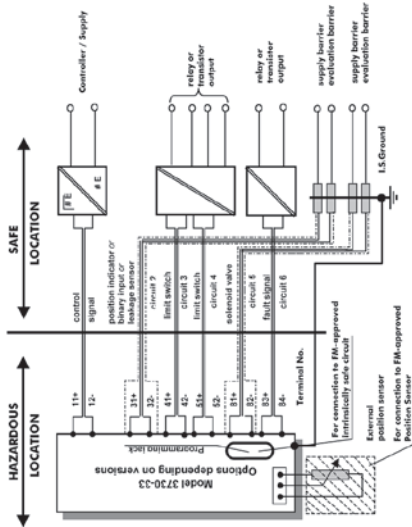

For the permissible maximum values for the intrinsically safe circuits 1,3,4 and 6 see Table 1
For the permissible barrier parameters for the circuits 2 and 5 see Table 2
Cable entry M 20 x 1.3 or metal conduit according to drawing No. 1050 - 0539 T
or 1050 - 0540 T

Revision Control Number: 3 Jun. 08

Addendum to EB 8384-3EN

FM-approved for hazardous locations

Class I, Division 2, Groups A, B, C, D,
Class II, Division 2, Groups F + G.

NEMA 4X

HART-capable positioner with position indicator or binary input or leakage detection, forced venting function (solenoid valve), fault signal and limit switches.

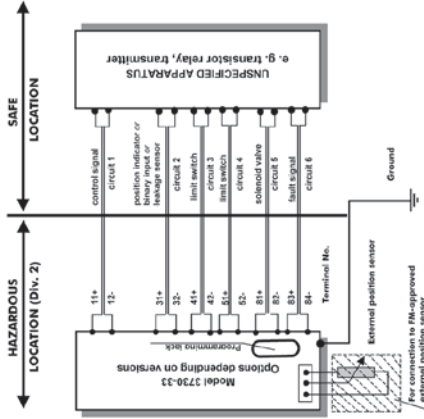

Notes:

- 1.) The installation shall be in accordance with the National Electrical Code ANSI/NFPA 70
- 2.) For the maximum values for the individual circuits see Table 1
Cable entry only rigid metal conduit

Revision Control Number: 3 Jun. 08

Addendum to EB 8384-3EN

Index

A

Accessories 50–52

Additional equipment

External position sensor 12

Leakage sensor 12

Limit switch 11

Solenoid valve 11

AIR TO OPEN/AIR TO CLOSE

slide switch 61

Analog input 12

Article code 9

Attachment

According to IEC 60534-6
(NAMUR) 26

Direct attachment

To Type 3277-5 Actuator 22

To Type 3277 Actuator 24

Reversing amplifier 38

Stainless steel housing 49

To rotary actuators 34

To Type 3510 Micro-flow Valve 34

Automatic mode 79

B

Bar graph 63

Binary contact

Electrical connection 56

Binary input 12

Blocking position, canceling 77

C

Code list 88–105

Condensed state 81

Configuration

At the positioner 79

With TROVIS-VIEW 13

Connections

Electric 56

Pneumatic 55

Controlled variable 10

D

Default settings 78

Defining the valve closed position 66

Dimensions 106–108

Display 62

E

Electrical connections 56

Enable configuration 79

Error message 98–104

Confirm 82

External position sensor 12, 42

According to IEC 60534-6 45

Direct attachment 43

Electrical connection 42

Pneumatic connection 42

To rotary actuators 47

To Type 3510 Micro-flow Valve 46

F

Fail-safe position (SAFE) 80

Fault 81–82

Recommended action 98–104

I

Initialization

Manually selected range (MAN) 70, 73

Maximum range (MAX) 70, 71

Nominal range (NOM) 70, 72

Substitute calibration (SUB) 70, 74

- L**
- Leakage sensor 12
 - Attachment..... 48
 - Limit switch
 - Electrical connection..... 56
 - Setting..... 83–84
- M**
- Maintenance..... 86
 - Malfunction 81–82
 - Manual mode 79
 - Mounting parts 50–52
- O**
- Operating elements 61
 - Operating modes 79–80
 - Operating range
 - Check 69
 - Manually selected range (MAN) 70, 73
 - Maximum range (MAX)..... 70, 71
 - Nominal range (NOM) 70, 72
 - Operation..... 79–82
 - Output variable..... 10
- P**
- Pneumatic connections 55
 - Principle of operation 10
 - Purging of actuator spring chamber 49
- R**
- Reading
 - Display 61
 - On display..... 62
 - Turn by 180° 67
 - Reference variable (set point)..... 10
 - Reset 78
 - Reversing amplifier..... 38
 - Rotary pushbutton 61
- S**
- Select characteristic 92, 110–111
 - Serial interface..... 13, 86
 - Signal pressure
 - Limit..... 68
 - Signal pressure gauges..... 55
 - Software update..... 86
 - Solenoid valve 11
 - Electrical connection..... 56
 - Start-up..... 66–78
 - Status classification..... 98
 - Status messages 63
 - Substitute calibration (SUB) 70, 74
 - Supply pressure..... 55
- T**
- Technical data..... 14
 - Travel tables..... 20
- U**
- Update 86
- V**
- Valve diagnostics 11
 - Volume restriction 61
 - Setting 67
- Z**
- Zero calibration 77



SAMSON AG · MESS- UND REGELTECHNIK
Weismüllerstraße 3 · 60314 Frankfurt am Main, Germany
Phone: +49 69 4009-0 · Fax: +49 69 4009-1507
samson@samson.de · www.samson.de

EB 8384-3 EN

2016-10-11 · English