

MOUNTING AND OPERATING INSTRUCTIONS



EB 8394 EN

Translation of original instructions



Hardware version 01.xx.xx



Hardware version GI:00

Series 3725

Type 3725 Electropneumatic Positioner

Firmware version 1.12



Edition November 2024

Note on these mounting and operating instructions

These mounting and operating instructions assist you in mounting and operating the device safely. The instructions are binding for handling SAMSON devices. The images shown in these instructions are for illustration purposes only. The actual product may vary.

- For the safe and proper use of these instructions, read them carefully and keep them for later reference.
- If you have any questions about these instructions, contact SAMSON's After-sales Service (aftersaleservice@samsongroup.com).



Documents relating to the device, such as the mounting and operating instructions, are available on our website at www.samsongroup.com > **Downloads > Documentation.**

Definition of signal words

DANGER

Hazardous situations which, if not avoided, will result in death or serious injury

WARNING

Hazardous situations which, if not avoided, could result in death or serious injury

NOTICE

Property damage message or malfunction

Note

Additional information

Tip

Recommended action

1	Safety instructions and measures	6
1.1	Notes on possible severe personal injury	9
1.2	Notes on possible personal injury	10
1.3	Notes on possible property damage	10
2	Markings on the device	12
2.1	Nameplate	12
2.2	Article code	13
3	Design and principle of operation	16
3.1	Types of attachment	16
3.2	Accessories and mounting parts	18
3.3	Travel tables	22
3.4	Technical data	23
3.5	Dimensions in mm	25
4	Measures for preparation	29
4.1	Unpacking	29
4.2	Transporting and lifting	29
4.2.1	Transporting	29
4.2.2	Lifting	29
4.3	Storage	29
5	Mounting and start-up	30
5.1	Lever and pin position	30
5.2	Direct attachment	32
5.2.1	Type 3277-5 and Type 2780-2 Actuators	32
5.2.2	Type 3277 Actuator	36
5.3	Attachment according to IEC 60534-6	38
5.4	Attachment to Type 3372 Actuator (V2001)	40
5.5	Attachment to rotary actuators	42
5.5.1	Heavy-duty version	44
5.5.2	Mounting the Type 3710 Reversing Amplifier	46
5.6	Pneumatic connections	47
5.7	Connecting the supply air	47
5.7.1	Signal pressure connection	47
5.7.2	Supply pressure	48
5.8	Electrical connections	49
5.8.1	Electric power supply	50
5.8.2	Cable entry	50
5.8.3	Connecting the electrical power	50

Contents

6	Operation	52
6.1	Operating controls	52
6.1.1	Capacitive keys.....	52
6.1.2	Volume restriction Q.....	52
6.1.3	Display	53
7	Operating the positioner.....	54
7.1	Adapting the display.....	55
7.2	Enabling configuration to change parameters.....	55
7.3	Adjusting the volume restriction Q.....	56
7.4	Entering the direction of action.....	57
7.5	Entering the direction of action.....	57
7.6	Limiting the signal pressure.....	58
7.7	Setting other parameters.....	59
7.8	Initialization	59
7.8.1	Canceling initialization.....	60
7.9	Zero calibration	61
7.9.1	Canceling zero calibration.....	61
7.10	Manual mode	62
7.11	Reset.....	63
8	Servicing.....	64
8.1	Cleaning the housing cover.....	64
8.2	Preparation for return shipment.....	64
9	Malfunctions	65
9.1	Clearing error codes	66
9.2	Error codes.....	67
9.3	Emergency action	68
10	Decommissioning and removal	69
10.1	Decommissioning.....	69
10.2	Removing the positioner	69
10.3	Disposal.....	69
11	Appendix.....	70
11.1	After-sales service	70
11.2	Code list.....	71
11.2.1	Parameter codes	71

Firmware revisions	
1.02 (old)	1.03 (new)
	Internal revisions
1.03 (old)	1.10 (new)
	Setting of the travel in steps of 0.5 mm (P4 parameter code)
	Monitoring of the end stops only during initialization and in manual mode
	To suppress common-mode interference on the signal lines, the D component of the positioner is switched off when the actuator is at a standstill.
1.10 (old)	1.11 (new)
	Internal revisions
1.11 (old)	1.12 (current version)
	Internal revisions
Hardware revisions	
GI:00 (old)	01.00.00 (new)
	New device cover made of polyphthalamide (PPA) with a round window made of polycarbonate (PC) (old: device cover with square window made of polycarbonate (PC))

1 Safety instructions and measures

Intended use

The SAMSON Type 3725 Positioner is mounted on pneumatic control valves and used to assign the valve position to the control signal. The device is designed to operate under exactly defined conditions (e.g. operating pressure, temperature). Therefore, operators must ensure that the positioner is only used in applications where the operating conditions correspond to the technical data. In case operators intend to use the positioner in applications or conditions other than those specified, contact SAMSON.

SAMSON does not assume any liability for damage resulting from the failure to use the device for its intended purpose or for damage caused by external forces or any other external factors.

➔ Refer to the technical data for limits and fields of application as well as possible uses.

Reasonably foreseeable misuse

The Type 3725 Positioner is **not** suitable for the following applications:

- Use outside the limits defined during sizing and by the technical data

Furthermore, the following activities do not comply with the intended use:

- Use of non-original spare parts
- Performing maintenance activities not described in these instructions

Qualifications of operating personnel

The positioner must be mounted, started up and serviced by fully trained and qualified personnel only; the accepted industry codes and practices must be observed. According to these mounting and operating instructions, trained personnel refers to individuals who are able to judge the work they are assigned to and recognize possible hazards due to their specialized training, their knowledge and experience as well as their knowledge of the applicable standards.

Explosion-protected versions of this device must be operated only by personnel who has undergone special training or instructions or who is authorized to work on explosion-protected devices in hazardous areas.

Personal protective equipment

No personal protective equipment is required for the direct handling of the positioner. Work on the control valve may be necessary when mounting or removing the device.

- Observe the requirements for personal protective equipment specified in the valve documentation.
- Check with the plant operator for details on further protective equipment.

Revisions and other modifications

Revisions, conversions or other modifications of the product are not authorized by SAMSON. They are performed at the user's own risk and may lead to safety hazards, for example. Furthermore, the product may no longer meet the requirements for its intended use.

Safety features

Upon failure of the air supply and/or electrical signal, the positioner vents the actuator, causing the valve to move to the fail-safe position determined by the actuator.

Warning against residual hazards

The positioner has direct influence on the control valve. To avoid personal injury or property damage, plant operators and operating personnel must prevent hazards that could be caused in the control valve by the process medium, the operating pressure, the signal pressure or by moving parts by taking appropriate precautions. Plant operators and operating personnel must observe all hazard statements, warnings and caution notes in these mounting and operating instructions, especially for installation, start-up and service work.

If inadmissible motions or forces are produced in the pneumatic actuator as a result of the supply pressure, it must be restricted using a suitable supply pressure reducing station.

Responsibilities of the operator

Operators are responsible for proper use and compliance with the safety regulations.

Operators are obliged to provide these mounting and operating instructions to the operating personnel and to instruct them in proper operation. Furthermore, operators must ensure that operating personnel or third parties are not exposed to any danger.

Responsibilities of operating personnel

Operating personnel must read and understand these mounting and operating instructions as well as the specified hazard statements, warnings and caution notes. Furthermore, the operating personnel must be familiar with the applicable health, safety and accident prevention regulations and comply with them.

Safety instructions and measures

Servicing explosion-protected devices

If a part of the device on which the explosion protection is based needs to be serviced, the device must not be put back into operation until a qualified inspector has assessed it according to explosion protection requirements, has issued an inspection certificate, or given the device a mark of conformity. Inspection by a qualified inspector is not required if the manufacturer performs a routine test on the device before putting it back into operation and the passing of the routine test is documented by attaching a mark of conformity to the device. Replace explosion-protected components only with original, routine-tested components by the manufacturer.

Devices that have already been operated outside hazardous areas and are intended for future use inside hazardous areas must comply with the safety requirements placed on serviced devices. Before being operated inside hazardous areas, test the devices according to the specifications for servicing explosion-protected devices.

Maintenance, calibration and work on equipment

- Only use intrinsically safe current/voltage calibrators and measuring instruments for interconnection with intrinsically safe circuits to check or calibrate the equipment inside or outside hazardous areas.
- Observe the maximum permissible values specified in the certificates for intrinsically safe circuits.

Referenced standards, directives and regulations

Devices with a CE marking fulfill the following requirements of the Directives:

- Type 3725-0: 2011/65/EU, 2014/30/EU
- Type 3725-1100: 2011/65/EU, 2014/30/EU, 2014/34/EU

Referenced documents

The following documents apply in addition to these mounting and operating instructions:

- The mounting and operating instructions of the components on which the positioner is mounted (valve, actuator, valve accessories etc.).

1.1 Notes on possible severe personal injury

DANGER

Risk of fatal injury due to the ignition of an explosive atmosphere.

Incorrect installation, operation or maintenance of the positioner in potentially explosive atmospheres may lead to ignition of the atmosphere and ultimately to death.

- The following regulations apply to installation in hazardous areas: EN 60079-14 (VDE 0165, Part 1).
- Installation, operation or maintenance of the positioner is to be performed only by personnel who has undergone special training or instructions or who is authorized to work on explosion-protected devices in hazardous areas.

1.2 Notes on possible personal injury

WARNING

Risk of personal injury due to moving parts on the valve.

During initialization of the positioner and during operation, the valve moves through its entire travel range. Injury to hands or fingers is possible if they are inserted into the valve.

- During initialization, do not insert hands or fingers into the valve yoke and do not touch any moving valve parts.

1.3 Notes on possible property damage

NOTICE

Risk of damage to the positioner due to incorrect mounting position.

- Do not mount the positioner with the back of the device/vent opening facing upward.
- Do not seal the vent opening when the device is installed on site.

Risk of malfunction due to incorrect sequence during start-up.

The positioner can only work properly if the mounting and start-up are performed in the prescribed sequence.

- Perform mounting and start-up as described in Chapter 30 on page 5.

An incorrect electric signal will damage the positioner.

A current source must be used to power the positioner.

- Only use a current source and never a voltage source.

Incorrect assignment of the terminals will damage the positioner and will lead to malfunction.

For the positioner to function properly, the prescribed terminal assignment must be observed.

- Connect the electrical wiring to the positioner according to the prescribed terminal assignment.

Malfunction due to initialization not yet completed.

The initialization causes the positioner to be calibrated to adapt it to the mounting situation. After initialization is completed, the positioner is ready for use.

- Initialize the positioner on first start-up.
- Re-initialize positioner after changing the mounting position.

Risk of positioner damage due to incorrect grounding of the electric welding equipment.

- Do not ground electric welding equipment near the positioner.

Incorrect cleaning will damage the housing cover.

The housing cover of the hardware version GI:00 is made of Makrolon® and will be damaged when cleaned with abrasive cleaning agents or agents containing solvents.

- Do not rub the housing cover dry.
- Do not use any cleaning agents containing chlorine or alcohol or abrasive cleaning agents.
- Use a non-abrasive, soft cloth for cleaning.

Risk of damage to the housing cover due to excessively high torque being applied when tightening the housing screws.

- Tighten the cover screws with a tightening torque of 0.8 Nm at the maximum.

2 Markings on the device

2.1 Nameplate

The nameplate shown was up to date at the time of publication of this document. The nameplate on the device may differ from the one shown.

Version without explosion protection

SAMSON 3725		10
Positioner		
Supply	1	10
Input	2	
	See technical data for ambient temperature	
Date	3	13
SAM	4	
HV	5	
SV	6	
Mat.	7	
S/N	8	
Model 3725-	9	
SAMSON AG D-60314 Frankfurt		
Made in Germany		

Explosion-protected version

SAMSON 3725		10
Positioner		
Supply	1	10
Input	2	
11		13
12		
Date	3	
SAM	4	
HV	5	
SV	6	
Mat.	7	
S/N	8	
Model 3725-	9	
SAMSON AG Weismuellerstrasse 3		
D-60314 Frankfurt		
Made in Germany		

- | | | | |
|---|--|----|--|
| 1 | Supply pressure | 8 | Serial number |
| 2 | Input signal | 9 | Model number |
| 3 | Date of manufacture | 10 | Approval and ID of the notified body (if applicable) |
| 4 | Code for NAMUR Recommendation NE 53 (internal specification) | 11 | Explosion protection marking |
| 5 | Hardware version | 12 | Referenced documents |
| 6 | Software version | 13 | DataMatrix code (electronic nameplate) |
| 7 | Material number | | |

2.2 Article code

Positioner		Type 3725- x x x 0 0 0 0 x 0 0 x x x x																		
With LCD and autotune, 4 to 20 mA reference variable																				
Explosion protection ¹⁾																				
Without		0	0	0																
ATEX	II 2 G Ex ia IIC T4 Gb	1	1	0										9	8					
CCC Ex	Ex ia II T4 Gb	1	1	2										9	8					
TR CMU 1055	II 2 G Ex ia IIC T4 Gb	1	1	6										9	8					
CSA c/us	Ex ia IIC T4; Class I, Zone 0, AEx ia IIC T4; Class I, Div. 1, Groups A, B, C & D	1	3	0										9	8					
Approval certificates for ships																				
Without								0												
Bureau Veritas Certification								1						9	8					
Hardware version																				
G1:00														9	8					
01.00.00														9	7					
Firmware version																				
1.12																			9	3

¹⁾ See Table 1 for details on explosion protection certificates.

Markings on the device

Table 1: Summary of explosion protection certificates

Type	Certification		Type of protection
3725-1000	ATEX	Number PTB 11 ATEX 2020 X Date 2019-02-25	II 2 G Ex ia IIC T4 Gb
3725-112	CCC Ex	Number 2021322307003871 Date 2023-04-29 Valid until 2026-04-04	Ex ia II T4 Gb
3725-116	TR CMU 1055	Number ZETC/35/2021 Date 2021-07-26 Valid until 2024-07-24	II 2 G Ex ia IIC T4 Gb
3725-130	CSA c/us	Number 2703735 X Date 2014-06-03	Ex ia IIC T4; Class I, Zone 0, AEx ia IIC T4; Class I, Div. 1, Groups A, B, C, D

Table 2: Approval certificates for ships

BV Type Approval Certificate	Number 46564/B0 BV.pdf Date 2022-01-11 Valid until 2027-01-11
-------------------------------------	---

3 Design and principle of operation

The Type 3725 Electropneumatic Positioner is mounted on pneumatic control valves and used to assign the valve position (controlled variable x) to the control signal (reference variable w). The positioner compares the electric control signal of a control system to the travel or opening angle of the control valve and issues a signal pressure (output variable y) for the pneumatic actuator.

The positioner mainly consists of the following components (see Fig. 1):

- Magneto-resistive sensor (2)
- Analog i/p converter (6) with a downstream air booster (7)
- Electronics unit with microcontroller (4)

The travel or opening angle is measured by the pick-up lever, non-contact magneto-resistive sensor and downstream electronics.

The pick-up lever is connected to a magnet inside the device. The motion of the pick-up lever causes the direction of the magnetic field to change. This change is sensed by the sensor (2). The electronics unit determines the current position of the actuator stem or opening angle from this information.

The position of the actuator stem or opening angle is transmitted to the microcontroller (3) over the A/D converter (4). The PD control algorithm in the microprocessor (4) compares this actual position to the 4 to 20 mA control signal after it has been converted by the A/D converter. In case of a system devi-

ation, the activation of the i/p module (6) is changed so that the actuator of the valve (1) is pressurized or vented accordingly over the downstream booster (7). The supply air is supplied to the air capacity booster (7) and the pressure regulator (8).

The output signal pressure supplied by the booster can be limited to 2.3 bar by software.

The volume restriction Q (10) is used to optimize the positioner by adapting it to the actuator.

Tight-closing function

The pneumatic actuator is completely filled with air or vented as soon as the reference variable falls below 1 % or exceeds 99 % (see set point cutoff in P10 and P11 parameter codes).

3.1 Types of attachment

The Type 3725 Positioner is suitable for the following types of attachment:

- Direct attachment to SAMSON Type 3277 and Type 2780-2 Actuators
 - Attachment to actuators according to IEC 60534-6 (NAMUR)
 - Attachment to Type 3372 Actuator (Series V2001 Valves)
 - Attachment to rotary actuators according to VDI/VDE 3845
- ➔ See Chapter 5.2 onwards for a description of the types of attachment.

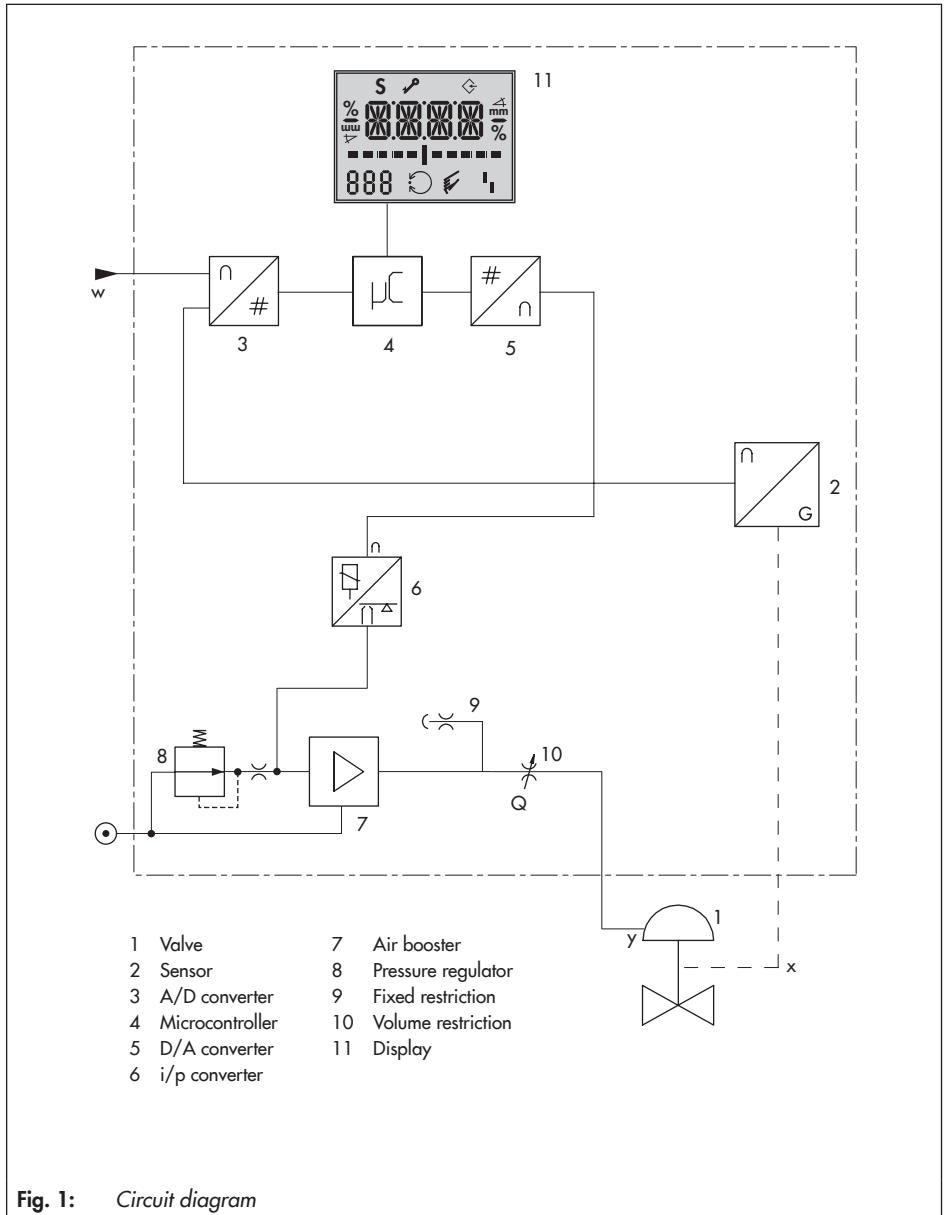

3.2 Accessories and mounting parts

Table 3: Direct attachment to Type 3277-5 and Type 2780-2 Actuators (see Chapter 5.2)		Order no.
Mounting parts		
For actuators up to 120 cm ²		1402-0239
Accessories for actuator		
Switchover plate for Type 3277-5xxxxx.01 Actuator		1400-6822
Connecting plate for additional attachment of, e.g. a solenoid valve: G 1/8		1400-6823
Accessories for positioner		
Connecting plate (6)	G 1/4	1402-0235
	1/4 NPT	1402-0236
Pressure gauge bracket (7)	G 1/4	1402-0237
	1/4 NPT	1402-0238
Pressure gauge bracket for combination with Type 4708-55 Supply Pressure Regulator		1402-1515
Pressure gauge mounting kit (8) up to max. 6 bar	Stainless steel/brass	1402-1637
	Stainless steel/stainless steel	1402-1638

Table 4: Direct attachment to Type 3277 (Chapter 5.2.2)		Order no.
Mounting parts		
Actuators 175, 240, 350, 355, 700, 750 cm ²		1402-0240
Accessories		
Connection block with seals and screw	G 1/4	1402-0241
	1/4 NPT	1402-0242
Pressure gauge mounting kit up to max. 6 bar	Stainless steel/brass	1402-1637
	Stainless steel/stainless steel	1402-1638

Table 5: Pipe connections for Type 3277 (direct attachment)				
Pipe connection	Actuator size	Material	Connection	Order no.
Piping with screw fittings – for fail-safe action "actuator stem retracts" – with air purging of the top diaphragm chamber	175 cm ²	Steel	G ¼ / G ¾	1402-0930
			¼ NPT/ ¾ NPT	1402-0958
		Stainless steel	G ¼ / G ¾	1402-0950
			¼ NPT/ ¾ NPT	1402-0964
	240 cm ²	Steel	G ¼ / G ¾	1402-0927
			¼ NPT/ ¾ NPT	1402-0959
		Stainless steel	G ¼ / G ¾	1402-0951
			¼ NPT/ ¾ NPT	1402-0965
	350 cm ²	Steel	G ¼ / G ¾	1402-0928
			¼ NPT/ ¾ NPT	1402-0960
		Stainless steel	G ¼ / G ¾	1402-0952
			¼ NPT/ ¾ NPT	1402-0966
	355 cm ²	Steel	G ¼ / G ¾	1402-0956
			¼ NPT/ ¾ NPT	1402-0961
		Stainless steel	G ¼ / G ¾	1402-0953
			¼ NPT/ ¾ NPT	1402-0967
700 cm ²	Steel	G ¼ / G ¾	1402-0929	
		¼ NPT/ ¾ NPT	1402-0962	
	Stainless steel	G ¼ / G ¾	1402-0954	
		¼ NPT/ ¾ NPT	1402-0968	
750 cm ²	Steel	G ¼ / G ¾	1402-0957	
		¼ NPT/ ¾ NPT	1402-0963	
	Stainless steel	G ¼ / G ¾	1402-0955	
		¼ NPT/ ¾ NPT	1402-0969	

Design and principle of operation

Table 6: Attachment to NAMUR rib or attachment to rod-type yokes according to IEC 60534-6 (Chapter 5.3)		Order no.
5 to 50 mm travel, lever already on positioner		
For actuators		1402-0330
Actuators from other manufacturers and Type 3271 with 120 to 750 cm ² effective areas		
Accessories		
Connecting plate	G ¼	1402-0235
	¼ NPT	1402-0236
Pressure gauge bracket	G ¼	1402-0237
	¼ NPT	1402-0238
Pressure gauge mounting kit up to max. 6 bar	Stainless steel/brass	1402-1637
	Stainless steel/stainless steel	1402-1638

Table 7: Attachment to rotary actuators (Chapter 5.5)		Order no.
Light version		
VDI/VDE 3845 (September 2010), fixing level 1 ¹⁾ , AA1 size		1402-0243
VDI/VDE 3845 (September 2010), fixing level 1 ¹⁾ , AA2 size		1402-0244
VE TEC Type S160 Actuator or SAMSON Type 3278 Rotary Actuator (160 cm ²)		1402-0294
VE TEC Type S320		1402-0295
Heavy-duty version		
VDI/VDE 3845 (September 2010), fixing level 1 ¹⁾ , AA1 to AA4 size		1402-1097
VDI/VDE 3845 (September 2010), fixing level 2 ¹⁾		1402-1099
VE TEC Type S160/R		1402-1098
Accessories		
Connecting plate	G ¼	1402-0235
	¼ NPT	1402-0236
Pressure gauge bracket	G ¼	1402-0237
	¼ NPT	1402-0238
Pressure gauge mounting kit up to max. 6 bar	Stainless steel/brass	1402-1637
	Stainless steel/stainless steel	1402-1638
Connecting plate for Type 3710 Reversing Amplifier		1402-0512

¹⁾ See page 27 for details.

Table 8: General accessories and spare parts		Order no.
M20x1.5 cable gland		
Black plastic		8808-1011
Blue plastic		8808-1012
Nickel-plated brass		1890-4875
Stainless steel 1.4305		8808-0160
M20x1.5 to ½ NPT adapter		
Powder-coated aluminum		0310-2149
Stainless steel		1400-7114
Brief instructions inside cover		
German	GI:00	0190-6173
	HV 01.00.00	100199873
English	GI:00	0190-6174
	HV 01.00.00	100199875

3.3 Travel tables

i Note

The **M** lever is included in the scope of delivery.

Direct attachment to Type 3277-5 and Type 3277 Actuators

Actuator size [cm ²]	Rated travel [mm]	Adjustment range at positioner			Required lever	Assigned pin position
		Min.	Travel	Max.		
120	7.5	5.0 mm	to	16.0 mm	M	25
120/175/240/350	15	7.0 mm	to	22.0 mm	M	35
355/700/750	30	10.0 mm	to	32.0 mm	M	50

Direct attachment to Type 2780-2 Actuator

Actuator size [cm ²]	Rated travel [mm]	Adjustment range at positioner			Required lever	Assigned pin position
		Min.	Travel	Max.		
120	6/12	5.0 mm	to	16.0 mm	M	25
120	15	7.0 mm	to	22.0 mm	M	35

Attachment according to IEC 60534-6 (NAMUR)

SAMSON Type 3271 Actuator Size [cm ²]	Rated travel [mm]	Travel of other valves		Required lever	Assigned pin position
		Min.	Max.		
120	7.5	5.0 mm	16.0/25.0 ¹⁾ mm	M	25
120/175/240/350	15	7.0 mm	22.0/35.0 ¹⁾ mm	M	35
700/750	7.5				
355/700/750	15/30	10.0 mm	32.0/50.0 ¹⁾ mm	M	50

¹⁾ When 'MAX' is selected as the nominal range (P4 code, see page 71)

Attachment to rotary actuators according to VDI/VDE 3845

Rotary actuators			Required lever	Assigned pin position
Min.	Opening angle	Max.		
24°	to	100°	M	90°

3.4 Technical data

Type 3725 Positioner	
Travel (adjustable)	Direct attachment to Type 3277: 5 to 30 mm Direct attachment to Type 2780-2: 6/12/15 mm Attachment to Type 3372 Actuator: 15/30 mm Attachment according to IEC 60534-6 (NAMUR): 5 to 50 mm Attachment to rotary actuators: 24 to 100°
Reference variable w (reverse polarity protection) Static destruction limit	4 to 20 mA signal range · Two-wire device Split-range operation 4 to 11.9 mA and 12.1 to 20 mA ±33 V
Minimum current	3.8 mA
Load impedance	Max. 6.3 V (corresponding to 315 Ω at 20 mA)
Supply air Air quality acc. to ISO 8573-1	Supply air: 1.4 to 7 bar (20 to 105 psi) Max. particle size and density: Class 4 · Oil content: Class 3 · Pressure dew point: Class 3 or at least 10 K below the lowest ambient temperature to be expected
Signal pressure (output)	0 bar up to the supply pressure · Can be limited to approx. 2.3 bar by software
Characteristic	3 characteristics for globe valves · 9 characteristics for rotary valves
Hysteresis	≤0.3 %
Sensitivity	≤0.1 %
Transit time	Only for actuators with initialization time > 0.5 s ¹⁾
Direction of action	w/x reversible
Air consumption	≤100 I _n /h with a supply pressure up to 6 bar and a signal pressure of 0.6 bar
Air output capacity	Actuator (supply): at Δp = 6 bar: 8.5 m _n ³ /h, at Δp = 1.4 bar: 3.0 m _n ³ /h K _{vmax} (20 °C) = 0.09 · Air output at the signal pressure output (38) can be restricted with the volume restriction Q to K _{vmin} (20 °C) ≈ 1/3 K _{vmax} (20°C) Actuator (exhaust): at Δp = 6 bar: 14.0 m _n ³ /h, at Δp = 1.4 bar: 4.5 m _n ³ /h K _{vmax} (20 °C) = 0.15 · Air output at the signal pressure output (38) can be restricted with the volume restriction Q to K _{vmin} (20 °C) ≈ 1/3 K _{vmax} (20°C)
Permissible ambient temperature	-20 to +80 °C -25 to +80 °C with metal cable gland The limits in the test certificates additionally apply for explosion-protected versions

¹⁾ For faster actuators, a volume restriction must be used. Otherwise, the initialization cannot be performed successfully.

Design and principle of operation

Safety	
Influences	Temperature: $\leq 0.15\%/10\text{ K}$ Effect of vibration: $\leq 0.25\%$ up to 2000 Hz and 4 g according to IEC 770 Supply air: None
Electromagnetic compatibility	Complying with EN 61000-6-2, EN 61000-6-3 and NAMUR Recommendation NE 21
Explosion protection	See Table 1 on page 14 for details on explosion protection certificates.
Degree of protection	IP 66
Conformity	
Materials	
Housing	Polyphthalamide (PPA)
Cover	GI:00 Cover with integrated square window: polycarbonate (PC) HV 01.00.00 Cover made of polyphthalamide (PPA) with round window made of polycarbonate (PC)
External parts	Stainless steel 1.4571 and 1.4301
Cable gland	M20x1.5, black polyamide (PA)
Vent plug	High-density polyethylene (PE-HD)
Weight	Approx. 0.5 kg

3.5 Dimensions in mm

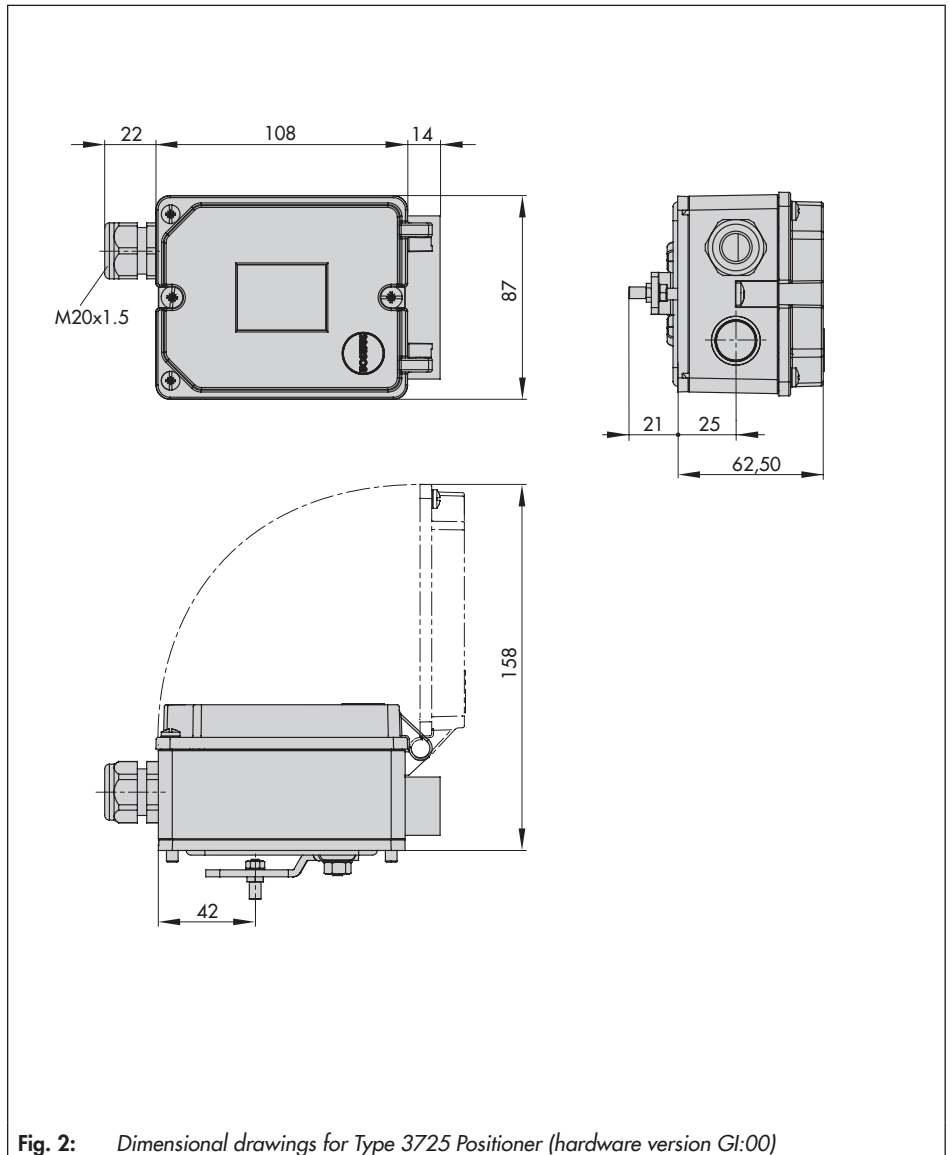

Design and principle of operation

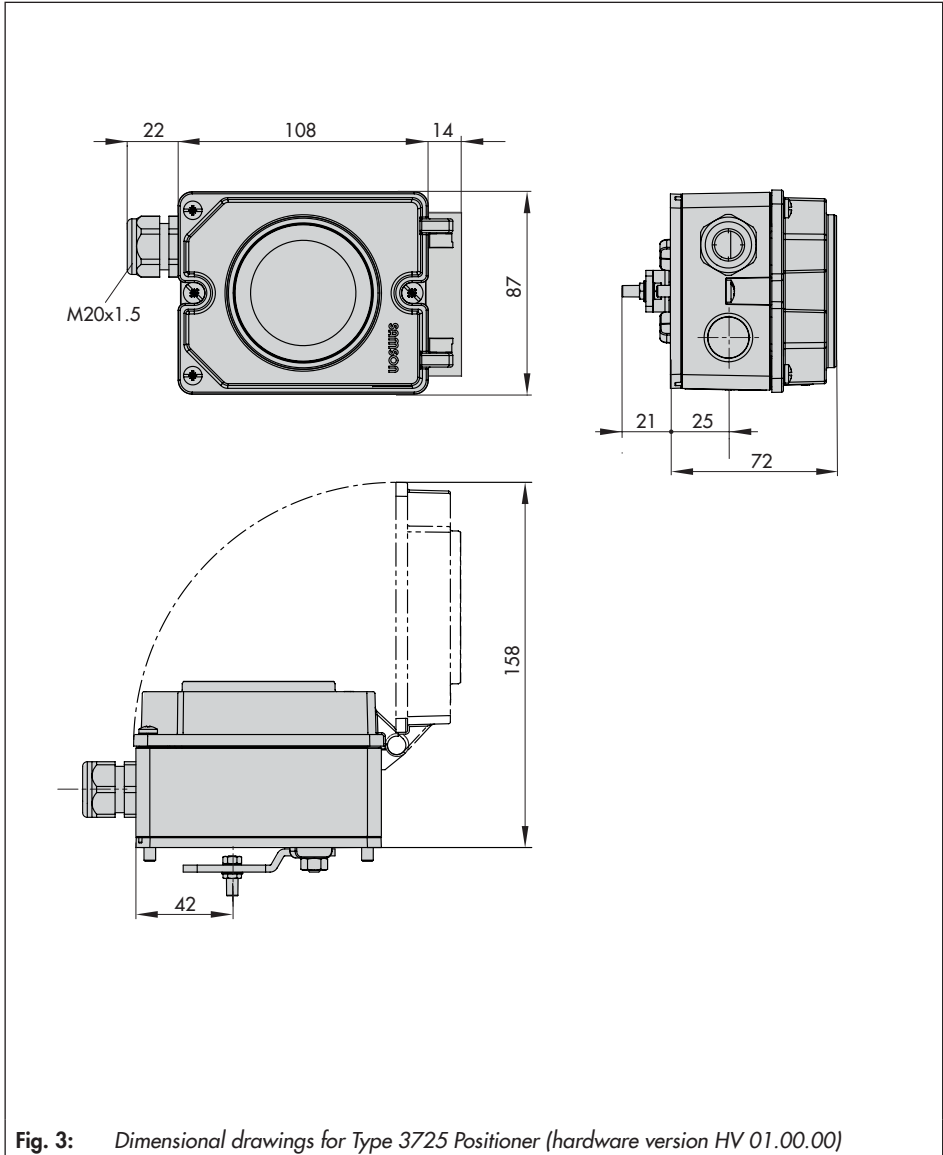

Fixing levels according to VDI/VDE 3845 (September 2010)

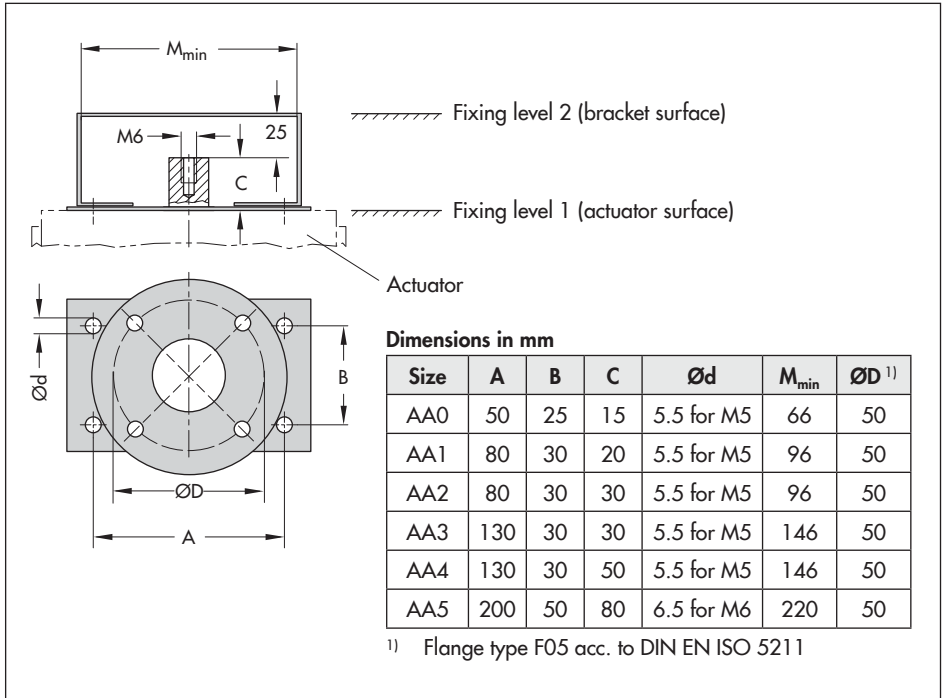

4 Measures for preparation

After receiving the shipment, proceed as follows:

1. Check the scope of delivery. Compare the shipment received with the delivery note.
2. Check the shipment for transportation damage. Report any transportation damage.

4.1 Unpacking

! NOTICE

Risk of positioner damage due to foreign particles entering it.

→ Do not remove the packaging and protective film/protective caps until immediately before mounting and start-up.

1. Remove the packaging from the positioner.
2. Dispose of the packaging in accordance with the valid regulations.

4.2 Transporting and lifting

4.2.1 Transporting

- Protect the positioner against external influences (e.g. impact).
- Protect the positioner against moisture and dirt.
- Observe transport temperature depending on the permissible ambient temperature (see technical data in Chapter 3.4).

4.2.2 Lifting

Due to the low service weight, lifting equipment is not required to lift the positioner.

4.3 Storage

! NOTICE

Risk of positioner damage due to improper storage.

- Observe the storage instructions.
- Avoid longer storage periods.
- Contact SAMSON in case of different storage conditions or longer storage times.

Storage instructions

- Protect the positioner against external influences (e.g. impact, shocks, vibration).
- Do not damage the corrosion protection (coating).
- Protect the positioner against moisture and dirt. In damp spaces, prevent condensation. If necessary, use a drying agent or heating.
- Observe storage temperature depending on the permissible ambient temperature (see technical data in Chapter 3.4).
- Store the positioner with the cover closed.
- Seal pneumatic and electrical connections.

5 Mounting and start-up

! NOTICE

Risk of malfunction due to incorrect sequence of mounting, installation and start-up.

→ Observe the prescribed sequence.

→ Sequence to be kept on mounting, installing and starting up the positioner:

1. Remove the protective caps from the pneumatic connections.

2. Mount the positioner on the valve.

→ Chapter 5.2 onwards

3. Perform pneumatic installation.

→ Chapter 5.6 onwards

4. Perform electrical installation.

→ Chapter 5.8 onwards

5. Perform settings.

→ Chapter 7 onwards

The following applies when mounting the positioner:

→ Do not mount the positioner with the vent opening (Fig. 5) facing upward.

→ Do not seal the vent opening.

The following applies to the housing cover of the positioner:

→ Tighten the cover screws with a tightening torque of 0.8 Nm at the maximum.

5.1 Lever and pin position

The positioner is adapted to the actuator and to the rated travel by the lever on the back of the positioner and the pin inserted into the lever.

The travel tables on page 22 show the assignment between the required lever and pin position.

The positioner is equipped with the **M** lever (pin position **35**) as standard (see Fig. 4).

Removing the lever and changing the pin position:

! NOTICE

Incorrect removal of the lever will damage the positioner.

→ Only remove the lever when it is positioned at the bottom mechanical stop.

1. Move the lever to the bottom mechanical stop (see Fig. 5) and hold it in place. Undo and remove the nut using a wrench (width across flats SW 10).
2. Remove the lever from the shaft.
3. Insert pin in position as listed in the travel table.
4. Fasten the lever.

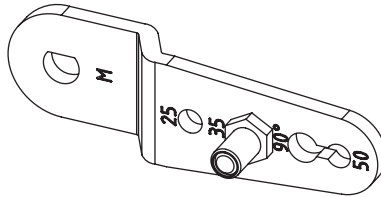

Fig. 4: M lever with pin position 35

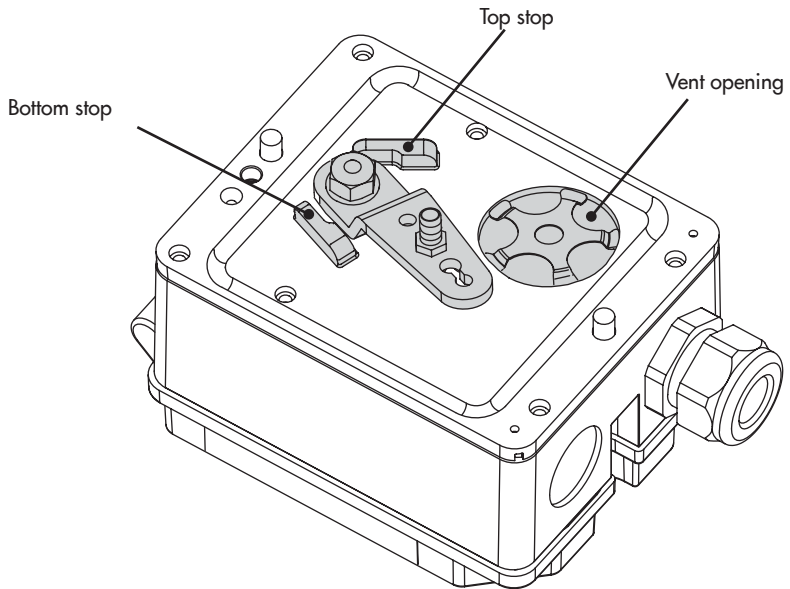

Fig. 5: Mechanical stops and vent opening

5.2 Direct attachment

5.2.1 Type 3277-5 and Type 2780-2 Actuators

- Required mounting parts and accessories: Table 3 on page 18.
- Observe travel tables on page 22.

Actuator (120 cm²)

Depending on the type of positioner attachment, the signal pressure is routed either left or right of the yoke through a hole to the actuator diaphragm.

- Depending on the fail-safe action of the actuator "actuator stem extends" or "actuator stem retracts", first attach the switchover plate (9) to the actuator yoke (while aligning it with the corresponding symbol for left or right attachment according to the marking, see Fig. 7).

1. Mount connecting plate (6) or pressure gauge bracket (7) with pressure gauges on the positioner. Make sure that the two seals (6.1) are seated properly.
2. Screw the screw plug (4) on the back of the positioner into the hole below it (park position) (see Fig. 9) and seal the signal pressure output on the connecting plate (6) or on the pressure gauge bracket (7) with the stopper (5) included in the accessories.
3. Place follower clamp (3) on the actuator stem, align it and screw tight so that the mounting screw is located in the groove of the actuator stem.

4. **15 mm travel:** Keep the follower pin (2) on the M lever (1) on the back of the positioner in the pin position 35 (delivered state). **7.5 mm travel:** Remove the follower pin (2) from the pin position 35, reposition it in the hole for pin position 25 and screw tight.
5. Insert molded seal (15) into the groove of the positioner housing.
6. Place positioner on the actuator in such a manner that the follower pin (2) rests on top of the follower clamp (3). While doing this, press on the ribbed area shown in Fig. 7 to lock the pick-up lever in the top position. The lever (1) must rest on the follower clamp with spring force.

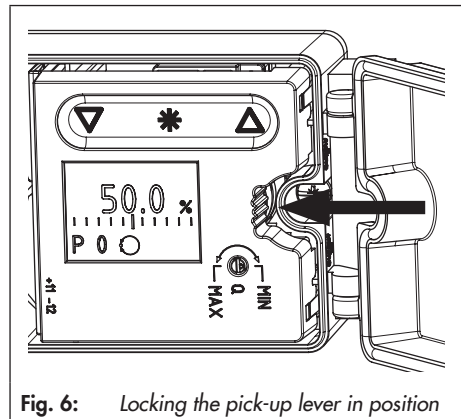
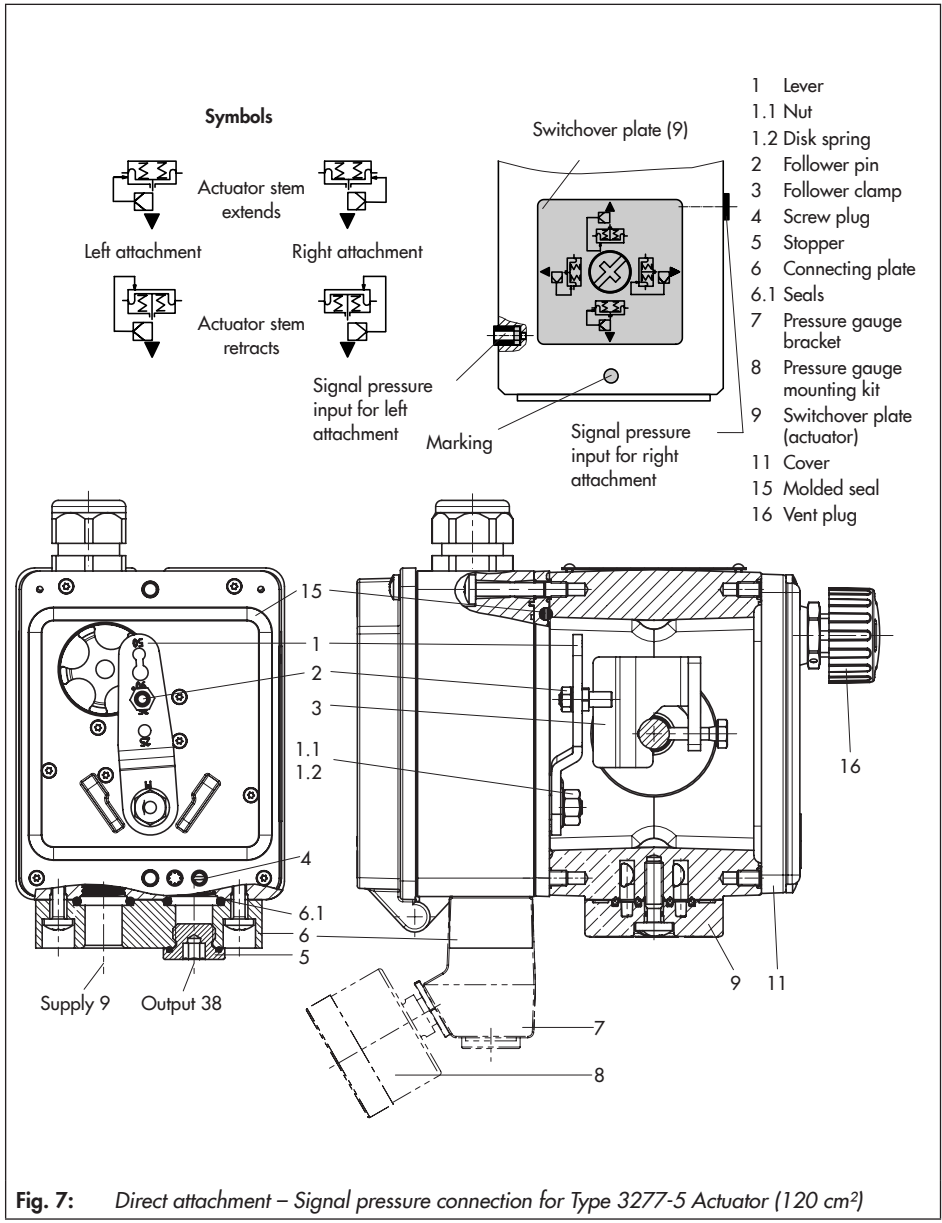
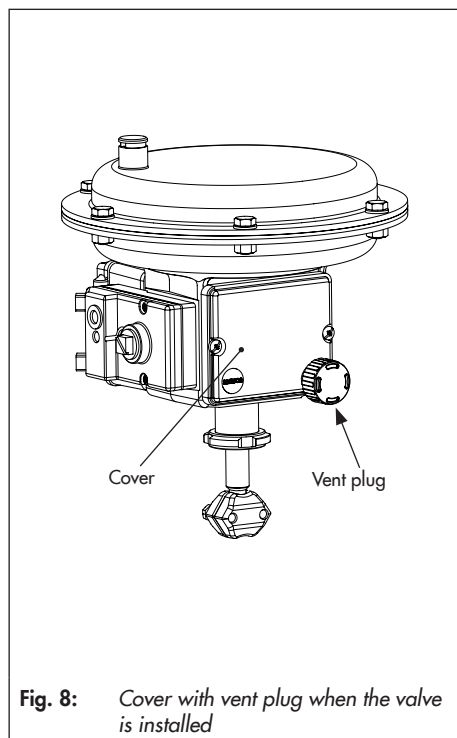

Fig. 6: Locking the pick-up lever in position

7. Mount the positioner on the actuator using the two fixing screws.
8. Mount cover (11) on the other side. Make sure that the vent plug is located at the bottom when the control valve is installed to allow any condensed water that collects to drain off (Fig. 8).





Additional solenoid valve

If a solenoid valve is additionally mounted onto the actuator, the signal pressure port at the back of the positioner must be sealed (see Fig. 9). To do this, unscrew the screw plug located in the middle hole (screw plug in park position) and screw it into the signal pressure port to seal it.

In this case, route the signal pressure from the signal pressure output to the actuator over the connecting plate (6) or pressure gauge bracket (7). The connecting plate (accessories for the actuator) replaces the switchover plate (9).

i Note

The switchover plate and connecting plate are accessories for the actuator (120 cm²). They are listed in Chapter 3.2 on page 18

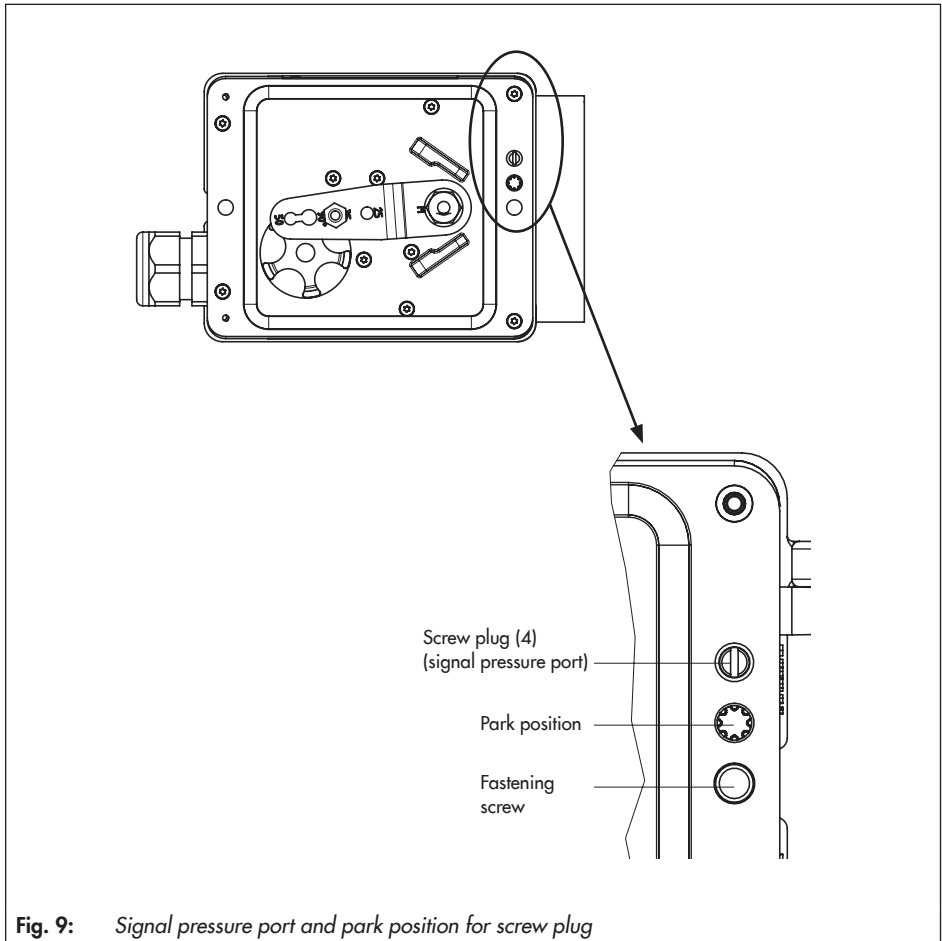

5.2.2 Type 3277 Actuator

→ Required mounting parts and accessories: Table 4 on page 18.

→ Observe travel tables on page 22.

Actuators with 175 to 750 cm² effective areas

The positioner can be mounted either on the left or right side of the yoke. The signal pressure is routed to the actuator over the connection block (12), for actuators with fail-safe action "actuator stem extends" internally through a hole in the valve yoke and for "actuator stem retracts" through an external pipe.

Place follower clamp (3) on the actuator stem, align it and screw tight so that the mounting screw is located in the groove of the actuator stem.

1. For actuators 175 and 350 cm² with 15 mm travel, keep the pin (2) in pin position 35.

For actuators with 355 or 750 cm², remove the pin (2) on M lever (1) on the back of the positioner from pin position 35, reposition it in the hole for pin position 50 and tighten.

2. Insert molded seal (15) in the groove of the positioner housing.
3. Place positioner on the actuator in such a manner that the pin (2) rests on top of the follower clamp (3).
4. While doing this, press on the ribbed area to lock the lever in the top position (see Fig. 6).

The lever (1) must rest on the follower clamp with spring force.

Fasten the positioner on the actuator using the two fixing screws.

5. Make sure that the tip of the gasket (16) projecting from the side of the connection block is positioned to match the actuator symbol for the actuator's fail-safe action "actuator stem extends" or "actuator stem retracts". If this is not the case, unscrew the three fastening screws and lift off the cover. Turn the gasket (16) by 180° and re-insert it.
6. Place the connection block (12) with the associated seals against the positioner and the actuator yoke and fasten using the screw (12.1).
7. For actuators with fail-safe action "Actuator stem retracts", additionally remove the stopper (12.2) and mount the external signal pressure pipe.
8. Mount cover (11) on the other side. Make sure that the vent plug is located at the bottom when the control valve is installed to allow any condensed water that collects to drain off (see Fig. 8 on page 34).

Type 3277 Actuator with Type 3725
Positioner (direct attachment) (image
shows device cover of hardware version
GI:00)

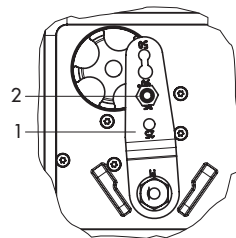
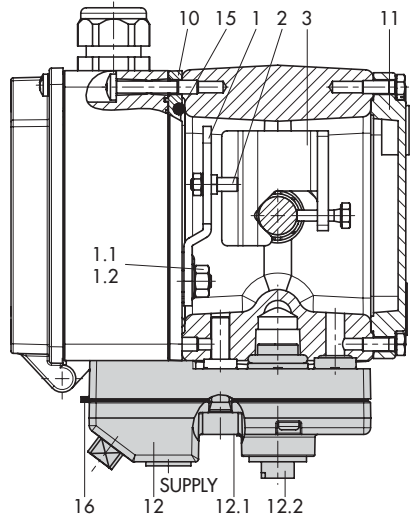

Ansicht A

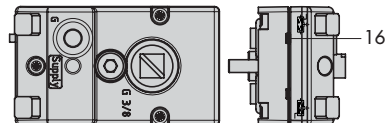

- 1 M lever
- 1.1 Nut
- 1.2 Disk spring
- 2 Follower pin
- 3 Follower clamp
- 11 Cover
- 12 Connection block
- 12.1 Screw
- 12.2 Stopper or connection for external piping
- 15 Molded seal
- 16 Gasket

Fig. 10: Direct attachment · Signal pressure connection for Type 3277 Actuator with 240 to 750 cm²

5.3 Attachment according to IEC 60534-6

The positioner is attached to the control valve using a NAMUR bracket (10).

- Required mounting parts and accessories: Table 6 on page 20.
 - Observe travel tables on page 22.
1. Screw the two bolts (14) to the bracket (9.1) of the stem connector (9), place the follower plate (3) on top and use the screws (14.1) for fastening.
 2. Fasten the NAMUR bracket (10) to the control valve.
 - For valve with NAMUR rib: Fasten the NAMUR bracket (10) using the M8 screw (11) and toothed lock washer directly to the yoke hole.
 - For valves with rod-type yoke: Place the two U-bolts (16) around the stem. Position the NAMUR bracket (10) and fasten it using the nuts, washers and toothed lock washers.
 3. Align the NAMUR bracket (10) so that its mounting holes are approximately in line to the middle of the travel scale indicator (15) (the slot of the follower plate must be centrally aligned with the NAMUR bracket at mid valve travel).
 4. Mount connecting plate (6) or pressure gauge bracket (7) with pressure gauges (8) on the positioner. Make sure that the two seals (6.1) are seated properly.
 5. Place positioner on the NAMUR bracket in such a manner that the pin (2) rests in

the slot of the follower plate (3). Adjust the lever (1) correspondingly.

Fasten the positioner to the NAMUR bracket using its two mounting screws.

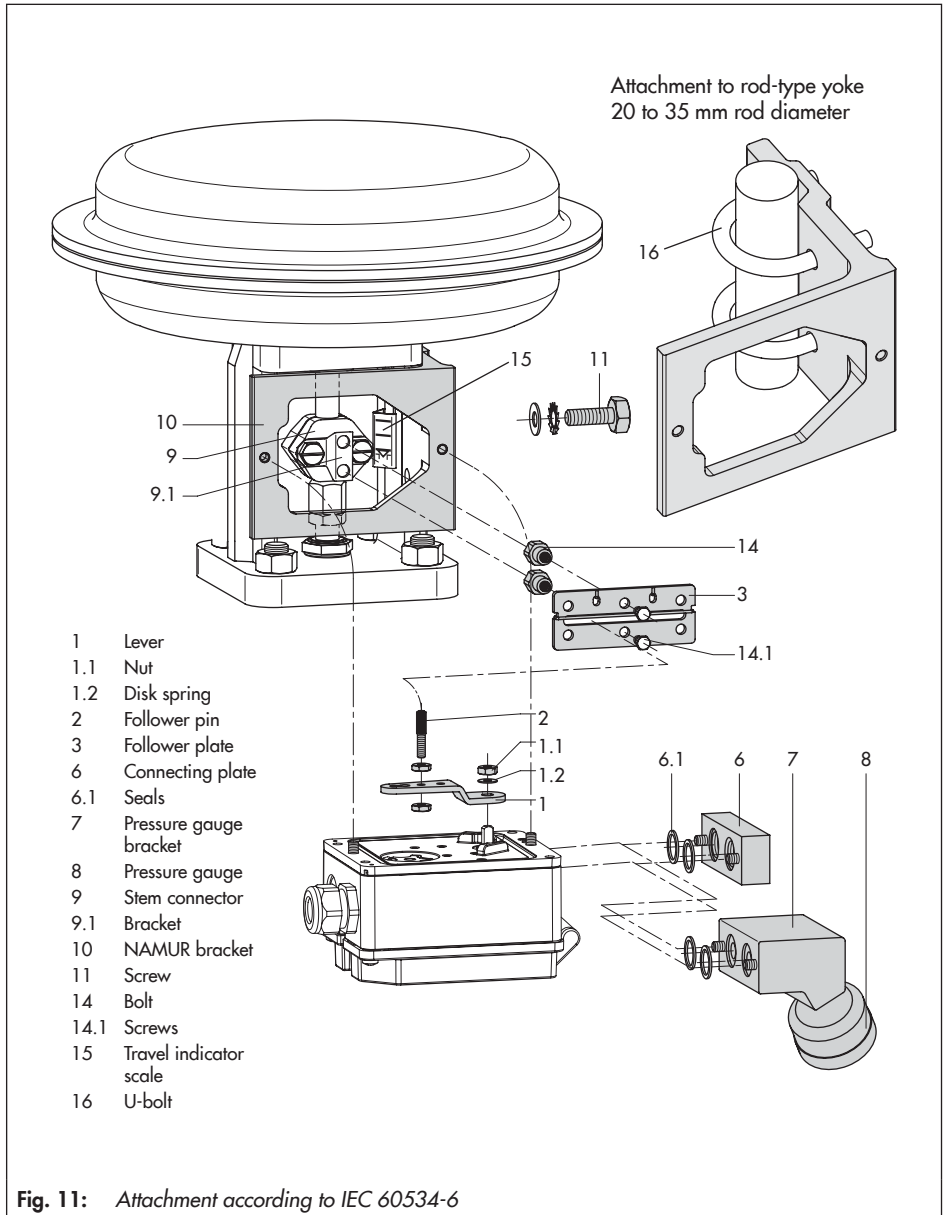

5.4 Attachment to Type 3372 Actuator (V2001)

The Type 3725 Positioner is already included in the scope of delivery for Series V2001 Valves (Fig. 12).

The attachment is briefly described below to allow conversion work to be performed.

Actuator with 120/350 cm², stem extends

The signal pressure is routed through the corresponding port in the support element to the actuator diaphragm.

→ Thread the screw plug on the positioner into the hole below (park position) (see Fig. 9 on page 35).

Actuator with 120/350 cm², stem retracts

The signal pressure is routed through piping at the side of the support element to the actuator diaphragm.

Attachment including solenoid valve

The signal pressure is routed from the output port of the positioner to the solenoid valve and through a corresponding hole in the support element to the actuator diaphragm.



**Type 3372 Actuator, version
with 120 cm²**



**Type 3372 Actuator, version
with 350 cm²**

Fig. 12: Attachment to Type 3372 Actuator (image shows device cover of hardware version GI:00)

5.5 Attachment to rotary actuators

The positioner is mounted to the rotary actuator using a mounting bracket.

- ➔ Required mounting parts and accessories: Table 7 on page 20.
 - ➔ Before attaching the positioner onto the SAMSON Type 3278 Rotary Actuator (160 cm²) or VETEC Type S160 Actuator, first mount the adapter (13) to the free end of the shaft end using four screws (10.2).
1. Place follower clamp (3) on the slotted actuator shaft or adapter (13).
 2. Place coupling wheel (4) with flat side facing the actuator on the follower clamp (3). Align slot so that it matches the direction of rotation when the valve is in its closed position (see Fig. 13).
 3. Fasten the coupling wheel (4) and follower clamp (3) tightly onto the actuator shaft using screw (4.1) and disk spring (4.2).
 4. Mount connecting plate (6) or pressure gauge bracket (7) with pressure gauges (8) on the positioner. Make sure that the two seals are seated properly.
 5. Fasten the mounting bracket (10) to the actuator using four screws (10.1).
 6. Unscrew the standard follower pin (2) from the positioner's M lever (1). Use the metal follower pin (Ø 5 mm) included in the mounting kit and screw tight into the hole for pin position 90°.

7. Place positioner on the mounting bracket (10) and tighten. Taking the actuator's direction of rotation into account, adjust lever (1) so that it engages in the slot of the coupling wheel (4) with its follower pin (Fig. 14).
- ➔ The lever (1) must be parallel to the long side of the positioner when the actuator is at half its angle of rotation.
8. Stick the scale plate on the coupling wheel (4) so that the arrow tip indicates the closed position and it can be easily read when the valve is installed.

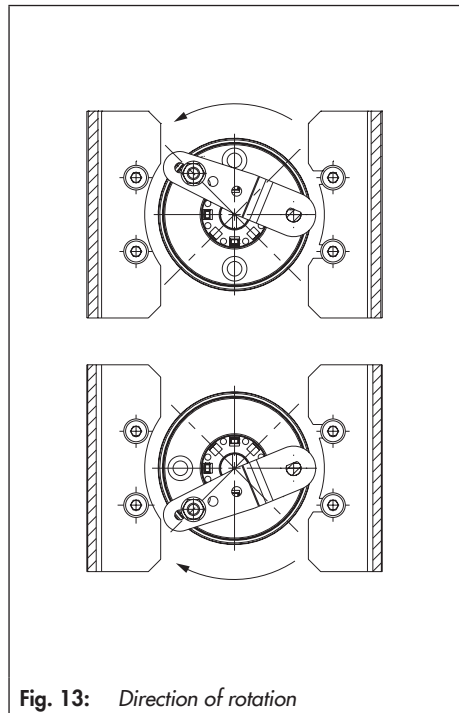

Fig. 13: Direction of rotation

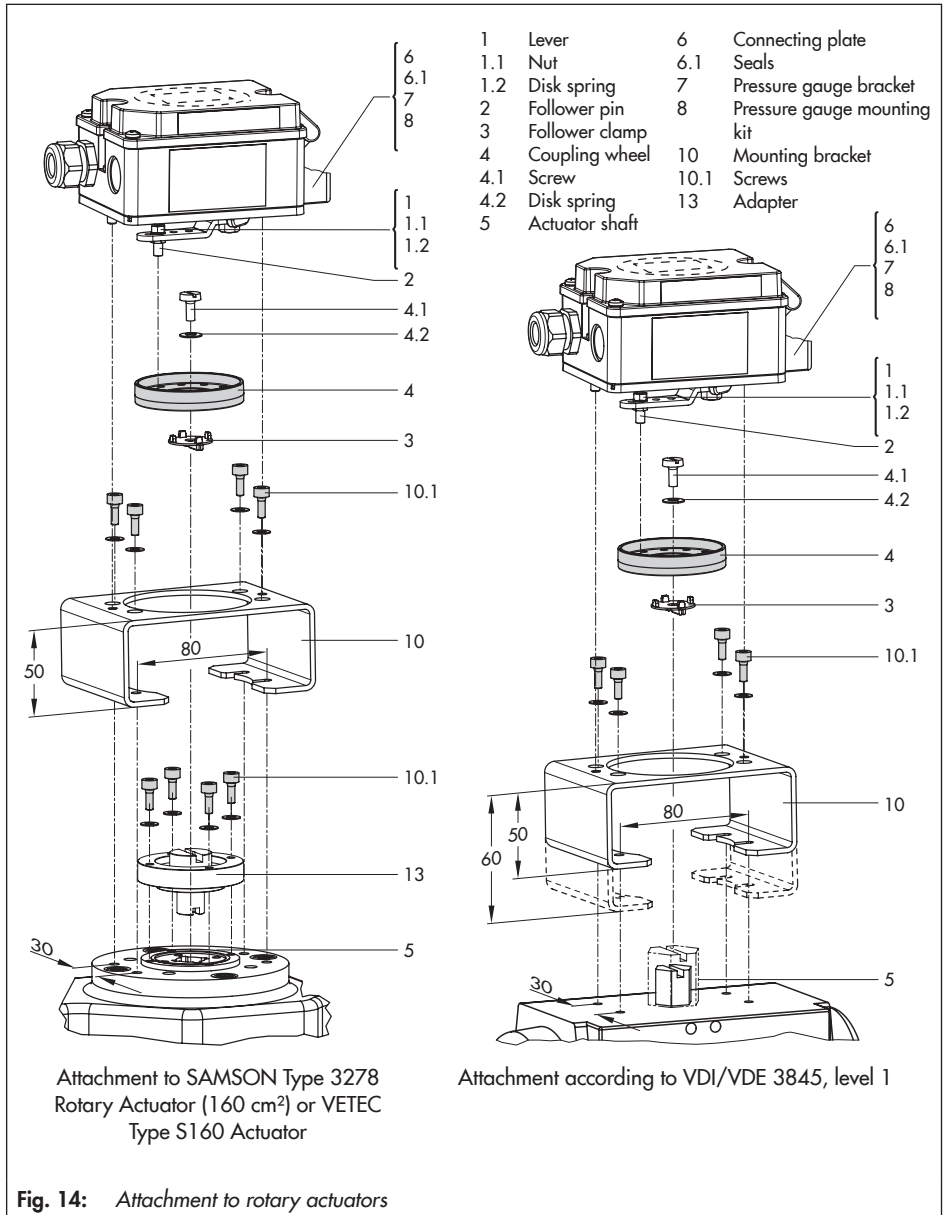

Fig. 14: Attachment to rotary actuators

5.5.1 Heavy-duty version

➔ Required mounting parts and accessories: Table 7 on page 20.

Prepare actuator and mount possibly required adapter supplied by the actuator manufacturer.

1. Mount the housing (10) onto the rotary actuator. In case of VDI/VDE attachment, place spacers (11) underneath, if necessary.
2. For **SAMSON Type 3278 and VETEC S160 Rotary Actuators**, fasten the adapter (5) onto the free end of the shaft and for **VETEC R Actuator**, place on the adapter (5.1). For **Type 3278, VETEC S160 and VETEC R Actuators**, place on the adapter (3). For Type 3278, VETEC S160 and **VETEC R Actuators**, place on the adapter (3). For VDI/VDE version, this step depends on the actuator size.
3. Stick adhesive label (4.3) onto the coupling wheel in such a manner that the yellow part of the sticker is visible in the window of the housing when the valve is OPEN. Adhesive labels with explanatory symbols are enclosed and can be stuck on the housing, if required.
4. Fasten coupling wheel (4) on the slotted actuator shaft or adapter (3) using screw (4.1) and disk spring (4.2).
5. Unscrew the standard follower pin (2) from the positioner's M lever (1). Attach the follower pin (Ø5 mm) included in the mounting kit to pin position 90°.
6. Mount connecting plate (6) for required G ¼ connecting thread or pressure

gauge bracket (7) with pressure gauges on the positioner. Make sure that the two seals (6.1) are seated properly. Double-acting springless rotary actuators require the use of a reversing amplifier on the connection side of the positioner housing (see Chapter 5.5.2).

7. For actuators with a volume of less than 300 cm³, screw the screw restriction (order no. 1400-6964) into the signal pressure output of the positioner (or the output of the pressure gauge bracket or connecting plate).
8. Fasten the positioner onto the adapter plate (12).
9. Place the positioner together with the adapter plate on the housing (10) and screw it tight. Taking the actuator's direction of rotation into account, adjust lever (1) so that it engages in the correct slot with its follower pin (Fig. 15).

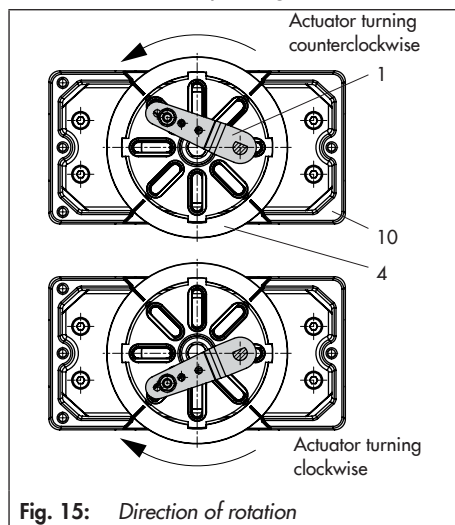
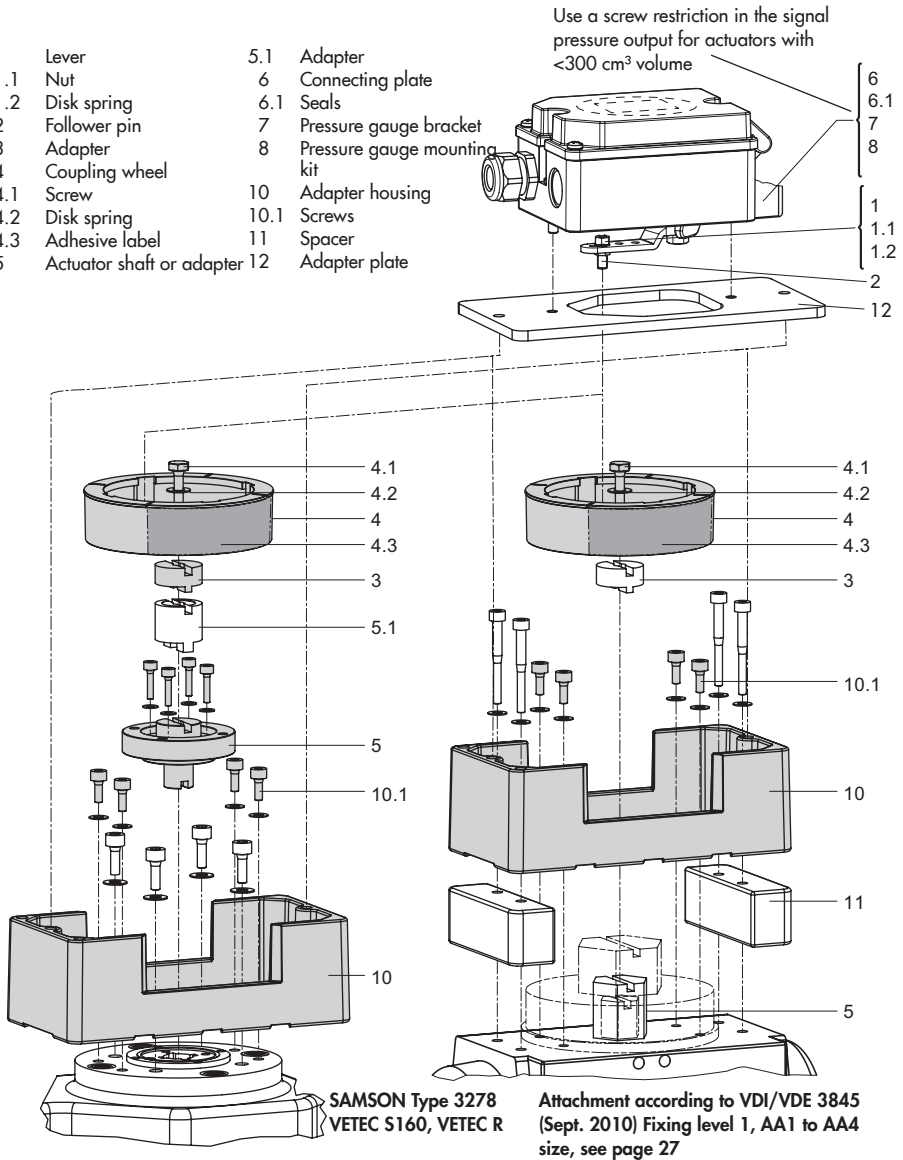

Fig. 15: Direction of rotation

- 1 Lever
- 1.1 Nut
- 1.2 Disk spring
- 2 Follower pin
- 3 Adapter
- 4 Coupling wheel
- 4.1 Screw
- 4.2 Disk spring
- 4.3 Adhesive label
- 5 Actuator shaft or adapter

- 5.1 Adapter
- 6 Connecting plate
- 6.1 Seals
- 7 Pressure gauge bracket
- 8 Pressure gauge mounting kit
- 10 Adapter housing
- 10.1 Screws
- 11 Spacer
- 12 Adapter plate

Use a screw restriction in the signal pressure output for actuators with <math><300\text{ cm}^3\text{ volume}</math>



SAMSON Type 3278
VETEC S160, VETEC R

Attachment according to VDI/VDE 3845
(Sept. 2010) Fixing level 1, AA1 to AA4
size, see page 27

Fig. 16: Attachment to rotary actuators (heavy-duty version)

5.5.2 Mounting the Type 3710 Reversing Amplifier

When a Type 3710 Reversing Amplifier is used, a connecting plate is placed between the positioner and reversing amplifier. The reversing amplifier is fastened together with the connecting plate to the positioner using screws (Fig. 17).

i Note

The screws supplied with the connecting plate have a TORX PLUS® profile (size 25 IP) and must be tightened using a suitable tool.

Details on the Type 3710 Reversing Amplifier: Mounting and Operating Instructions

► EB 8392

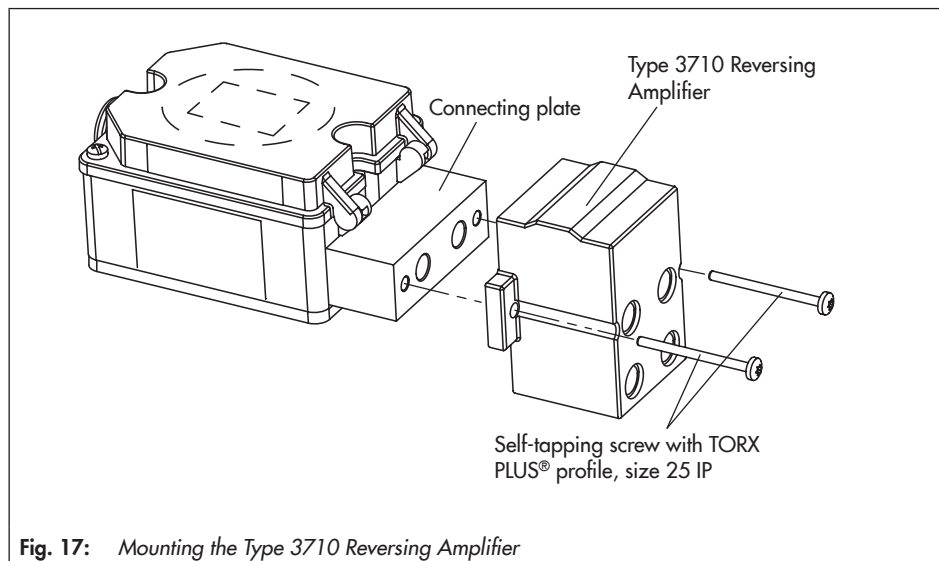

Fig. 17: Mounting the Type 3710 Reversing Amplifier

5.6 Pneumatic connections

⚠ WARNING

Risk of injury by possible movement of the actuator stem after connecting the signal pressure.

→ Do not touch or block the actuator stem.

ⓘ NOTICE

Incorrect connection of the supply air will damage the positioner and will lead to malfunction.

→ Screw the screw fittings into the connecting plate, pressure gauge mounting block or connection block from the accessories.

→ Keep the length of the line as short as possible to avoid delays in control signal transmission.

The pneumatic connections are optionally designed as a bore with ¼ NPT or G ¼ thread. The customary fittings for metal and copper pipes or plastic hoses can be used.

ⓘ NOTICE

Risk of malfunction due to failure to comply with air quality requirements.

→ Only use supply air that is dry and free of oil and dust.

→ Read the maintenance instructions for upstream pressure reducing stations.

→ Blow through all air pipes and hoses thoroughly before connecting them.

5.7 Connecting the supply air

ⓘ NOTICE

Risk of malfunction due to incorrect sequence of mounting, installation and start-up.

Observe the following sequence.

1. Remove the protective caps from the pneumatic connections.
2. Mount the positioner on the valve.
3. Connect the supply air.
4. Connect the electrical power.
5. Perform the start-up settings.

5.7.1 Signal pressure connection

The signal pressure connection depends on how the positioner is mounted onto the actuator:

Type 3277 Actuator

→ The signal pressure connection is fixed when the positioner is directly attached to the Type 3277 Actuator.

Mounting and start-up

Attachment according to IEC 60534-6 (NAMUR)

- For attachment according to IEC 60534-6 (NAMUR), the signal pressure can be routed to either the top or bottom diaphragm chamber of the actuator, depending on the actuator's fail-safe action "actuator stem extends" or "actuator stem retracts".

Rotary actuators (heavy-duty version)

- For rotary actuators, the manufacturer's specifications for connection apply.



Tip

To monitor the supply air and signal pressure, SAMSON recommends mounting pressure gauges (see Table 7 in Chapter 3.2).

Mounting the pressure gauges:

- See Fig. 11 and Chapter 5.3

5.7.2 Supply pressure

The required supply air pressure depends on the bench range and the actuator's operating direction (fail-safe action). The bench range is written on the nameplate either as the bench range or signal pressure range. The operating direction is marked **FA** or **FE** or by a symbol.

Fail-close or ATO (air to open):

Actuator stem extends

Fail-open or ATC (air to close):

Actuator stem retracts

Supply pressure for fail-close valves (for globe and angle valves):

- Required supply pressure = Upper bench range value + 0.2 bar, minimum 1.4 bar.

Supply pressure for fail-open valves (for globe and angle valves):

- For tight-closing valves, the maximum signal pressure $p_{st_{max}}$ is roughly estimated as follows:

$$p_{st_{max}} = F + \frac{d^2 \cdot \pi \cdot \Delta p}{4 \cdot A} \quad [\text{bar}]$$

d = Seat diameter [cm]

Δp = Differential pressure across the valve [bar]

A = Actuator area [cm²]

F = Upper bench range value [bar]

If there are no specifications, calculate as follows:

- Required supply pressure = Upper bench range value + 1 bar

i Note

The signal pressure at the output (38) of the positioner can be restricted to approx. 2.3 bar by setting P9 parameter code to ON.

5.8 Electrical connections

⚠ DANGER

Risk of fatal injury due to the formation of an explosive atmosphere.

For installation in hazardous areas, observe the relevant standards that apply in the country of use.

Standard applicable in Germany: EN 60079-14 (VDE 0165, Part 1) Explosive Atmospheres – Electrical Installations Design, Selection and Erection.

⚠ WARNING

Incorrect electrical connection will render the explosion protection unsafe.

- Adhere to the terminal assignment.
- Do not undo the enameled screws in or on the housing.
- Do not exceed the maximum permissible values specified in the EC type examination certificates when interconnecting intrinsically safe electrical equipment (U_i or U_o , I_i or I_o , P_i or P_o , C_i or C_o and L_i or L_o).

Selecting cables and wires

- **Observe clause 12 of EN 60079-14 (VDE 0165, Part 1) for installation of the intrinsically safe circuits.**
- Clause 12.2.2.7 applies when running multi-core cables and wires with more than one intrinsically safe circuit.
- **Radial thickness of the insulation** of a conductor for common insulating materials (e.g. polyethylene): **minimum 0.2 mm.**
- **Diameter of an individual wire** in a fine-stranded conductor: **minimum 0.1 mm.**
- Strip **8 mm** insulation off the wire ends.
- Protect the conductor ends against splicing, e.g. by using wire-end ferrules.

- Cable glands available:
See Table 8 on page 21

Mounting and start-up

Equipment for use in zone 2/zone 22

In equipment operated according to type of protection Ex nA II (non-sparking equipment) according to EN 60079-15: 2003:

- Circuits may be connected, interrupted or switched while energized only during installation, maintenance or repair.

Equipment connected to energy-limited circuits with type of protection Ex nL (energy-limited equipment) according to EN 60079-15: 2003:

- Equipment may be switched under normal operating conditions.

The maximum permissible values specified in the statement of conformity and its addenda apply when interconnecting the equipment with energy-limited circuits in type of protection Ex nL IIC.

5.8.1 Electric power supply

- Only use a current source and never a voltage source!
- Ensure that the reference variable remains below the static destruction limit of ± 33 V.

5.8.2 Cable entry

The M20x1.5 cable gland is designed for a clamping range of 6 to 12 mm.

The cage clamp terminals hold wire cross-sections of 0.2 to 1.5 mm².

- To unlock the cage clamp terminals: place a slotted screwdriver on the plastic part (Fig. 18) and lightly push it into the terminal block.
- Insert or remove the wire **without force**.

5.8.3 Connecting the electrical power

! NOTICE

Risk of malfunction due to incorrect sequence of mounting, installation and start-up.

Observe the following sequence.

1. Remove the protective caps from the pneumatic connections.
2. Mount the positioner on the valve.
3. Connect the supply air.
4. Connect the electrical power.
5. Perform the start-up settings.

- Connect the electrical power (mA signal) as shown in Fig. 18.

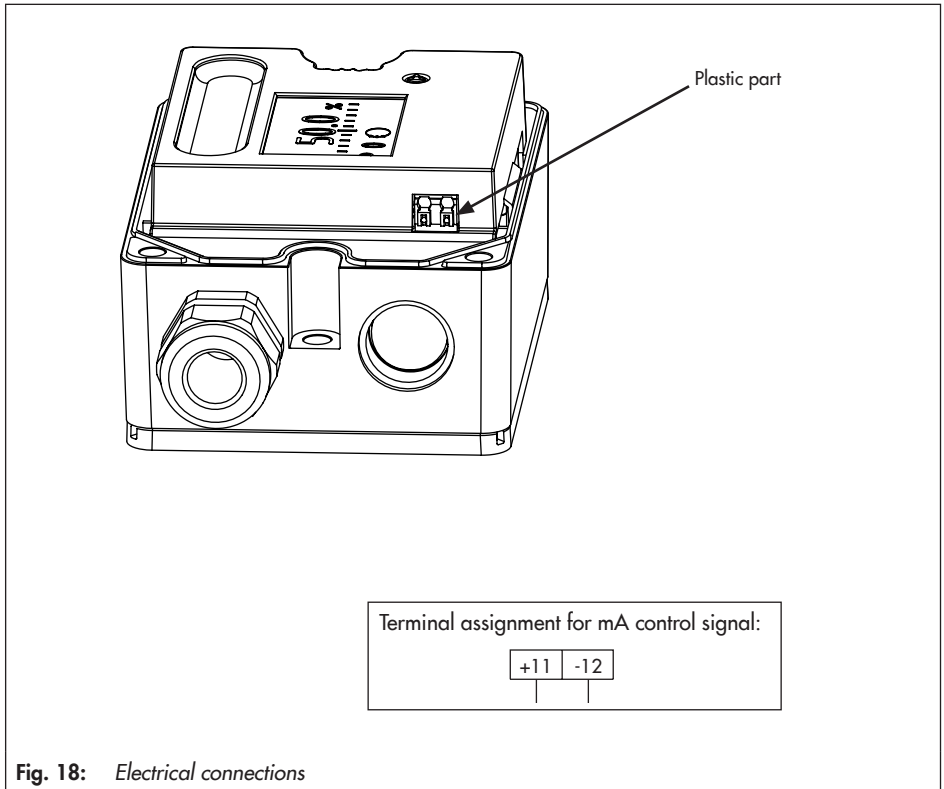

Fig. 18: *Electrical connections*

6 Operation

6.1 Operating controls

The positioner is operated using three capacitive keys. These capacitive keys allow the user to navigate within the menu on the display (Fig. 19). The volume restriction Q serves to adapt the air output capacity to the size of the actuator:

6.1.1 Capacitive keys

△: Up

*: Confirm

▽: Down

Touch △ or ▽ key to select a parameter code (**P0** to **P20**). Then touch * key to confirm the selected code.

To save changes to parameters in a non-volatile memory, proceed as follows:

- After changing parameters, press △ or ▽ to change to Code **P0** or
- wait three minutes until the display returns automatically to **P0**.

i Note

- The  icon on the display indicates that the changed parameter settings have not yet been saved in the non-volatile memory.
 - The selected parameter code remains active until you change the setting or exit the parameter code.
 - After changing settings in **P2**, **P4** and **P8** parameter codes, the positioner must be re-initialized.
-

6.1.2 Volume restriction Q

The volume restriction serves to adapt the air output capacity to the size of the actuator. Two fixed settings are possible (see Chapter 7.3).

6.1.3 Display

Icons which are assigned to certain codes and functions are indicated on the display (Fig. 19). The bar elements indicate the system deviation that depends on the sign (+/-) and the value. One bar element appears per 1 % system deviation.

If the positioner has not yet been initialized, the lever position in degrees in relation to the mid-axis is indicated. One bar element corresponds to approximately a 7° angle of rotation.

If the fault indication icon  is displayed, press  or  until **ERR** is displayed to view the **E0** to **E15** error codes (see Chapter 9.2).

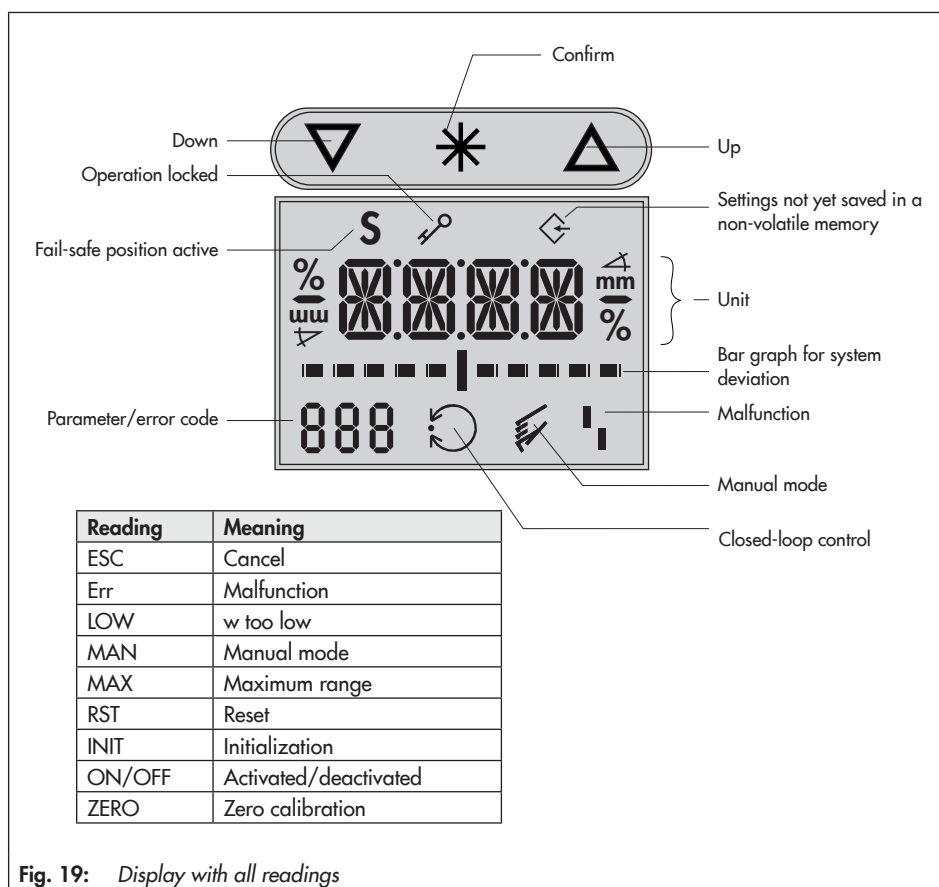

Fig. 19: Display with all readings

7 Operating the positioner

Before start-up, mount the positioner following the sequence described in Chapter 5. Apply the electric reference variable to start up the positioner (see Chapter 5.8.3).

i Note

- **LOW** on the display indicates that the reference variable is lower than 3.8 mA.
- The positioner is ready for operation with its default settings for most applications.
- After connecting the electrical signal (power supply), the positioner performs a calibration of the capacitive keys which takes approx. three seconds. During this time, do not touch the key panel. Otherwise, the keys will not work properly. Disconnect and reconnect the electrical signal to restart the calibration of keys.

Reading after connecting the power supply

Reading when the positioner has **not** yet been initialized

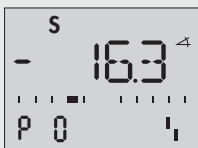

Code **P0** is displayed. The  fault indication icon and **S** (fail-safe position) appear on the display.

The reading indicates the lever position in degrees in relation to the mid-axis.

Reading when the positioner has been initialized:



Code **P0** is displayed. The positioner is in closed-loop operation indicated by the  closed-loop operation icon.

The indicated value corresponds to the control position in %.

Details on initialization of the positioner: Chapter 7.8.

7.1 Adapting the display

The display reading direction can be rotated by 180°. If the displayed data appear upside down, proceed as follows:



6. Touch Δ or ∇ until Code **P1** appears.
7. Press \ast to confirm the selected code. **P1** blinks.
8. Touch Δ or ∇ until the display is set in the desired direction.
9. Press \ast to confirm display direction.

7.2 Enabling configuration to change parameters

Before changing parameter settings in an initialized positioner, configuration must be enabled first by selecting Code **P19**:



LOCK and the key icon indicate that the configuration is locked. Deactivate locking as follows:

1. Touch Δ or ∇ until Code **P19** appears.
2. Press \ast to confirm the selected code. **P19** blinks.
3. Touch Δ or ∇ until **OPEN** is displayed.
4. Touch \ast to unlock operation.

i Note

If no settings are entered within three minutes, the enabled configuration function becomes invalid.

7.3 Adjusting the volume restriction Q

The volume restriction Q (see Fig. 20) serves to adapt the air output capacity to the size of the actuator:

Actuators with a **transit time** < 1 s, e.g. linear actuators with an effective area smaller than 240 cm², require a restricted air flow rate.

→ Setting to **MIN** (reduces the air flow rate by 1/3).

Actuators with a **transit time** ≥ 1 s do not require the air flow rate to be restricted.

→ Setting to **MAX**

Additional points that apply concerning the volume restriction:

→ Intermediate settings are not permitted.

→ Re-initialize positioner after changing the volume restriction setting.

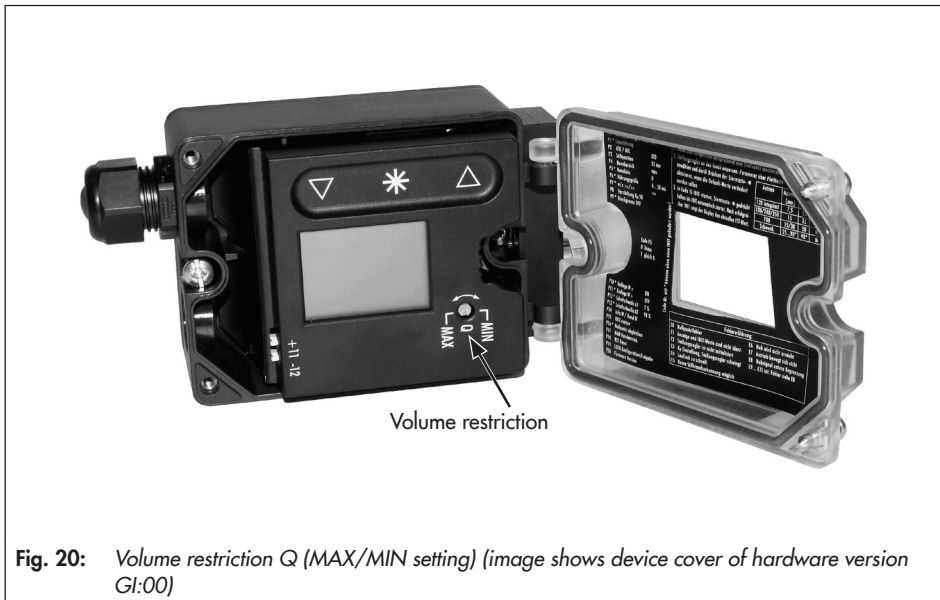

Fig. 20: Volume restriction Q (MAX/MIN setting) (image shows device cover of hardware version G1:00)

7.4 Entering the direction of action

- ATO (air to open) applies to a valve opening as the signal pressure increases.
- ATC (air to close) applies to a valve closing as the signal pressure increases.

The signal pressure is the pneumatic pressure at the output of the positioner applied to the actuator.



Default direction of action: **ATO**

Change the direction of action (enable configuration as described in Chapter 7.2):

1. Touch Δ or ∇ until Code **P2** appears.
2. Press \ast to confirm selected code. **P2** blinks.
3. Touch Δ or ∇ until the required direction of action appears.
4. Press \ast to confirm setting.

i Note

The changed direction of action first becomes effective after the positioner has been re-initialized.

7.5 Entering the direction of action

The direction of action (**P7**) is set to increasing/increasing (\gg) by default, i.e. when the positioner is initialized, **0** % is displayed when the valve is closed and **100** % when the valve is fully open. If necessary, the direction of action can be changed (enable configuration as described in Chapter 7.2):

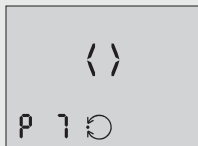

Changing the direction of action to increasing/decreasing:

1. Touch Δ or ∇ until Code **P7** appears.
2. Press \ast to confirm selected code. **P7** blinks.
3. Touch Δ or ∇ until \leftrightarrow appears.
4. Press \ast to confirm setting.

The following correlation applies:

Valve	CLOSED	OPEN
Display	0 %	100 %
Direction of action increasing/increasing (>>)	4 mA	20 mA
Direction of action increasing/decreasing (<<)	20 mA	4 mA

7.6 Limiting the signal pressure

If the maximum actuator force is too high for the valve used, the signal pressure limit can be activated in Code **P9**. The pressure is then limited to approx. 2.3 bar.



Activate the signal pressure limitation (enable configuration as described in Chapter 7.2):

1. Touch Δ or ∇ until Code **P9** appears.
2. Press $*$ to confirm selected code. **P9** blinks.
3. Touch Δ or ∇ until **ON** appears.
4. Press $*$ to confirm setting.

7.7 Setting other parameters

The following table lists all the parameter codes and their default settings. Proceed as described previously to change parameters.

More details concerning the parameter codes can be found in Chapter 11.2.

Parameter codes [default settings]			
P0	Status reading	P10	Set point cutoff decrease (end position w <) [ON]
P1	Reading direction	P11	Set point cutoff increase (end position w >) [OFF]
P2 ¹⁾	ATO/ATC [ATO]	P14	Display of reference variable w
P3 ¹⁾	Pin position [35]	P15	INIT Start initialization
P4 ¹⁾	Nominal range [MAX]	P16	ZERO Start zero calibration
P5	Characteristic [0]	P17	MAN Manual mode
P6	Reference variable [4 to 20 mA]	P18	RST Reset
P7	w/x direction of action [>>]	P19	Enable configuration
P8 ¹⁾	Gain Kp [50]	P20	Firmware version
P9	Pressure limitation 2.3 bar [OFF]		

¹⁾ Positioner needs to be re-initialized after changing the parameter setting

7.8 Initialization

During initialization the positioner adapts itself optimally to the friction conditions and the signal pressure required by the control valve.

⚠ WARNING

Risk of injury due to the actuator stem extending or retracting.

→ Do not touch or block the actuator stem.

📌 NOTICE

The process is disturbed by the movement of the actuator stem.

→ Do not initialize the positioner while the process is running and only after isolating the plant by closing the shut-off valves.

Operating the positioner

The type and extent of self-adaptation depends on the preset parameters. **MAX** applies as the default setting for the nominal range (Code **P4**). During the initialization process, the positioner determines the total travel range or rotational range of the valve (from the CLOSED position to the opposite end position).

Alternatively, a different travel can be selected in Code **P4** (see code list in Chapter 11.2).

i Note

The travel set in Code **P4** is only limited during initialization. However, it might be exceeded in closed-loop control when the control signal is higher than 20 mA.

Start initialization (enable configuration as described in Chapter 7.2).



1. Touch **Δ** or **▽** until Code **P15** appears.
2. Press ***** and hold for six seconds. 6...5...4...3...2...1 is counted down on the display.

The initialization starts and **INIT** blinks. The time required for the initialization procedure depends on the actuator transit time, which means that initialization can take a few minutes.



Initialization successfully completed. The positioner is in closed-loop operation indicated by the  closed-loop operation icon.

The indicated value corresponds to the control position in %.

Configuration is locked indicated by the key icon.

The fault indication icon  appears when the initialization fails.

7.8.1 Canceling initialization

The initialization can be canceled:

1. During initialization touch *****: **ESC** blinks on the display.
2. Press ***** to confirm: Initialization is canceled.

i Note

This code must be confirmed by pressing *****. Otherwise, the code remains active.

Initial state 1:

The positioner is **not** initialized.

The positioner goes to the fail-safe position after the initialization process has been canceled.

Initial state 2:

The positioner is initialized.

On canceling a new initialization process, the positioner returns to closed-loop operation.

The settings of the previous initialization are used.

A new initialization can be started directly afterwards.

7.9 Zero calibration

In case of inconsistencies in the closing position of the valve, e.g. with soft-seated plugs, it might be necessary to recalibrate zero over Code **P16** (enable configuration as described in Chapter 7.2).

Start the zero calibration by activating Code **P16** as follows:



1. Touch Δ or ∇ until Code **P16** appears.
2. Press $*$ and hold for six seconds. 6...5...4...3...2...1 is counted down on the display.

Zero calibration starts, **ZERO** blinks on the display.

The time required for the initialization procedure depends on the actuator transit time, which means that initialization can take a few minutes.

The positioner moves the control valve to the CLOSED position and recalibrates the internal electric zero point.

When the zero calibration has been successfully completed, the positioner changes to closed-loop operation.

7.9.1 Canceling zero calibration

Zero calibration can be canceled:

1. During zero calibration touch $*$: **ESC** blinks on the display.
2. Press $*$ to confirm: Zero calibration is canceled.

i Note

This code must be confirmed by pressing *****. Otherwise, the code remains active.

The positioner changes to closed-loop operation without performing a zero calibration. A new zero calibration can be started directly afterwards.

7.10 Manual mode

The valve position can be moved as follows using the **Manual mode** function:

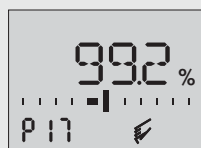

Enable configuration as described in Chapter 7.2.

1. Touch **Δ** or **∇** until Code **P17** appears.
2. Press ***** and hold for six seconds. **6-5-4-3-2-1-** is counted down on the display and **P17** blinks.

The manual set point is indicated on the display of an initialized positioner.

The lever position in degrees in relation to the mid-axis is indicated on the display of a positioner that has not been initialized.

3. Touch **Δ** or **∇** to change the manual set point.

Initialized positioner

The manual mode starts using the last set point used in closed-loop operation, ensuring a bumpless changeover.

The bar elements on the display indicate the system deviation between the manual set point and set point used for closed-loop control while manually moving the valve in Code **P17**.

The manual set point is adjusted in steps of 0.1 %. You can move the valve controlled within its range.

Positioner that has not been initialized

Touch **Δ** or **∇** for a long time to move the valve manually.

The valve is only moved in one direction uncontrolled. The bar elements on the display indicate the change in direction.

Touch ***** to deactivate manual mode.

i Note

The Manual mode function can only be exited as described or by interrupting the electrical supply (cold start). The positioner does **not** automatically exit this function and return to the display showing the status indication.

7.11 Reset

A reset causes an initialization to be undone and all parameters settings are reset to the default settings (see code list in Chapter 11.2).



Enable configuration as described in Chapter 7.2.

1. Touch Δ or ∇ until Code **P18** appears.
2. Press $*$ and hold for six seconds. 6...5...4...3...2...1 is counted down on the display.

RST blinks while $*$ is pressed. As soon as the key is released, the reset process is completed and the display returns to status indication (**P0**).

i Note

The **i** fault indication icon is displayed after a reset since the positioner needs to be re-initialized. The error code **E2** is also activated (see Chapter 9.2).

8 Servicing

i Note

The positioner was checked by SAMSON before it left the factory.

- The product warranty becomes void if service or repair work not described in these instructions is performed without prior agreement by SAMSON's After-sales Service.
- Only use original spare parts by SAMSON, which comply with the original specifications.

The Type 3725 Positioner requires no maintenance. There are filters with a 100 µm mesh size in the pneumatic connections for supply and output which can be removed and cleaned, if required.

- Observe the maintenance instructions of any upstream supply air pressure reducing stations.

8.1 Cleaning the housing cover

! NOTICE

Incorrect cleaning will damage the housing cover.

The housing cover of the hardware version GI:00 is made of Makrolon® and will be damaged when cleaned with abrasive cleaning agents or agents containing solvents.

- Do not rub the housing cover dry.
- Do not use any cleaning agents containing chlorine or alcohol or abrasive cleaning agents.
- Use a non-abrasive, soft cloth for cleaning.

8.2 Preparation for return shipment

Defective positioners can be returned to SAMSON for repair.

Proceed as follows to return devices to SAMSON:

1. Put the control valve out of operation. See associated valve documentation.
2. Remove the positioner (see Chapter 10.2)
3. Proceed as described on our website at www.samsongroup.com > Service > After-sales Service > Returning goods.

9 Malfunctions

In case of a fault, the fault indication icon  is displayed. Switch past Code **P0** or **P20** to display the respective error code **E0** to **E15** together with **ERR** appear on the display. Refer to the error code list in Chapter 9.2 for the cause of the errors and the recommended action.

Example:

If, for instance, a travel has been entered in Code **P4** (nominal range) which is larger than the maximum valve travel possible, the initialization process would be interrupted (**E2** error code) because the rated travel would not have been reached (**E6** error code). The valve moves to the fail-safe position (**S** indicated on the display).

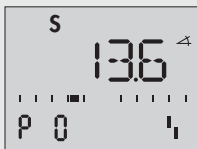

Display of the fault indication:

- Fault indication icon  appears.
- Valve moves to fail-safe position (**S** indicated on the display).

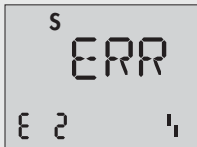

E2 error code: Initialization canceled.

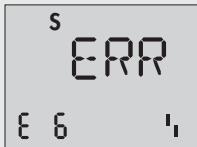

E6 error code: Rated travel not achieved.

The nominal range (Code P4) must be changed and the positioner re-initialized to remedy this problem.

9.1 Clearing error codes

The E0 and E8 error codes can be cleared as follows:

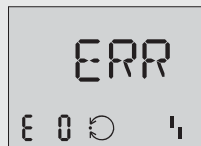

4. Touch Δ or ∇ to select the error code.

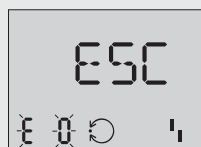

5. Touch $*$ to confirm the error code. **ESC** is displayed and the error code blinks.

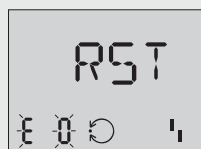

6. Touch Δ or ∇ until **RST** appears.
7. Press $*$ to clear the error.

The clearing procedure can be canceled by touching $$ when **ESC** appears.*

9.2 Error codes

The errors listed in the following table are assigned to error classes:

Error class 1: No operation possible

Error class 2: Manual operation only possible

Error class 3: Manual operation and closed-loop control possible

Contact SAMSON's After-sales Service for malfunctions not listed in the table in Chapter 11.1.

Code	Description		Class
E0	Zero error (operational error)	Only with tight-closing function P10 (set point cutoff decrease set to ON). The zero point has shifted by more than 5 % compared to initialization. The error may arise when the valve seat trim is worn.	3
	Recommended action	Check valve and positioner attachment. If the positioner is mounted correctly, perform a zero calibration over Code P16 (see Chapter 7.9). Error code can be cleared (see Chapter 9.1).	
E1	Displayed and INIT values are not identical (operational error)	Adjusted and displayed values are not identical to the INIT values as the parameters were changed after initialization.	3
	Recommended action	Reset parameters or perform initialization.	
E2	Positioner has not been initialized	Malfunction or parameter change requiring the positioner to be re-initialized.	2
	Recommended action	Set parameters and initialize the positioner over Code P15 .	
E3	K_p setting (initialization error)	Positioner hunts. Volume restriction set incorrectly, too much gain.	2
	Recommended action	Check the volume restriction setting as described in Chapter 7.3. Limit gain K _p in Code P8 . Re-initialize the positioner.	
E4	Transit time too short (initialization error)	The transit times of the actuator determined during initialization are so short (below 0.5 second) that optimal positioner tuning is not possible.	2
	Recommended action	Check the volume restriction setting as described in Chapter 7.3. Re-initialize the positioner.	

Malfunctions

E5	Standstill detection is not possible (initialization error)	Supply pressure varies. Mounting incorrect.	2
	Recommended action	Check supply air and positioner mounting. Re-initialize the positioner.	
E6	Travel is not achieved during initialization (initialization error)	Supply pressure is too low, actuator leaks, incorrect travel adjusted or pressure limit function activated. When MAX is selected for P4 code (nominal range): the measuring span of the lever is too small (incorrect lever, incorrect pin position). Initialization is canceled when the angle of rotation of the positioner shaft is smaller than 11°.	2
	Recommended action	Check supply air, positioner mounting, lever, pin position and setting. Re-initialize the positioner.	
E7	Actuator does not move (initialization error)	No supply air, mounting blocked.	2
	Recommended action	Check supply air, positioner mounting and mA input signal. Re-initialize the positioner.	
E8	Travel signal at lower/upper limit	Wrong pin position, wrong lever, wrong attachment direction when NAMUR attachment is used.	1
	Recommended action	Clear error code (see Chapter 9.1). Check positioner mounting and re-initialize the positioner.	
E9 to E15	Device error (internal)	Return device to SAMSON for repair.	1/3

9.3 Emergency action

Upon failure of the air supply and/or electrical signal, the positioner vents the actuator, causing the valve to move to the fail-safe position determined by the actuator.

Plant operators are responsible for emergency action to be taken in the plant.



Tip

Emergency action in the event of valve failure is described in the associated valve documentation.

10 Decommissioning and removal

⚠ DANGER

Risk of fatal injury due to ineffective explosion protection.

The explosion protection becomes ineffective when the positioner cover is opened.

→ The following regulations apply to installation in hazardous areas: EN 60079-14 (VDE 0165, Part 1).

ⓘ NOTICE

The process is disturbed by interrupting closed-loop control.

→ Do not mount or service the positioner while the process is running and only after isolating the plant by closing the shut-off valves.

10.1 Decommissioning

To decommission the positioner before removing it, proceed as follows:

1. Disconnect and lock the air supply and signal pressure.
2. Open the positioner cover and disconnect the wires for the control signal.

10.2 Removing the positioner

1. Disconnect the wires for the control signal from the positioner.

2. Disconnect the lines for supply air and signal pressure (not required for direct attachment using a connection block).
3. To remove the positioner, loosen the three fastening screws on the positioner.

10.3 Disposal



SAMSON is a producer registered in Europe,

▶ <https://www.samsongroup.com/en/about-samson/environment-social-governance/material-compliance/waste-electrical-and-electronic-equipment-veee-and-its-safe-disposal/>
WEEE reg. no.:
DE 62194439

- Observe local, national and international refuse regulations.
- Do not dispose of components, lubricants and hazardous substances together with your other household waste.

i Note

SAMSON can provide you with a recycling passport according to PAS 1049 on request. Simply e-mail us at aftersaleservice@samsongroup.com giving details of your company address.

💡 Tip

On request, SAMSON can appoint a service provider to dismantle and recycle the product as part of a distributor take-back scheme.

11 Appendix

11.1 After-sales service

Contact SAMSON's After-sales Service for support concerning service or repair work or when malfunctions or defects arise.

E-mail address

You can reach our after-sales service at aftersalesservice@samsongroup.com.

Addresses of SAMSON AG and its subsidiaries

The addresses of SAMSON AG, its subsidiaries, representatives and service facilities worldwide can be found on our website (www.samsongroup.com) or in all SAMSON product catalogs.

Required specifications

Please submit the following details:

- Order number and position number in the order
- Type, serial number, firmware version, device version

11.2 Code list

11.2.1 Parameter codes

Code	Display, values [default setting]	Description
Note: Codes marked by an asterisk (*) indicate that the positioner needs to be re-initialized afterwards		
P0	Status reading with basic information	The reading indicates the valve position or angle of rotation in % when the positioner is initialized. On touching * when the positioner is not initialized, the position of the lever in relation to the mid-axis is displayed.
P1	Reading direction	The reading direction of the display is turned by 180°.
P2*	ATO/ATC [ATO]	Parameter to adapt the positioner to how the valve functions: ATO: Air to open (valve CLOSED in fail-safe position), ATC: Air to close (valve OPEN in fail-safe position)
P3*	Pin position 17/25/[35]/50/90°	Insert follower pin in the proper position depending on the valve travel/opening angle (select according to travel tables on page 22).
P4*	Nominal range [MAX] Values with default setting [35]: e.g. 7.5/8.92/10.6/12.6/ 15.0/17.8/21.2 mm	Firmware 1.03 and lower: The possible adjustment range can be selected in stages depending on the selected pin position: 25 From 5.3 to 15.0 mm 35 From 7.5 to 21.2 mm 50 From 10.6 to 30.0 mm For 90° : Maximum range only, if P3 = 90° MAX : Maximum possible travel
	Nominal range [MAX]	Firmware 1.10 and higher: The possible adjustment range can be selected in steps of 0.5 mm depending on the selected pin position: 25 From 5.0 to 16.0 mm, alternatively MAX (up to 25.0 mm) 35 From 7.0 to 22.0 mm, alternatively MAX (up to 35.0 mm) 50 From 10.0 to 32.0 mm, alternatively MAX (up to 50.0 mm) For 90° : Maximum range only, if P3 = 90° MAX : Maximum possible travel

P15	Start initialization	Press * button to cancel the initialization process. As a result, the valve moves to the fail-safe position. After a power supply failure during initialization, the positioner starts with the values of the last initialization (if available).
P16	Start zero calibration	The zero calibration process can be interrupted by touching *. The control valve returns to closed-loop operation. Note: A zero calibration cannot be started when E1 error code exists. After a power supply failure during zero calibration, the positioner starts with the settings from the last zero calibration.
P17	Manual mode	Press Δ or ▽ to enter the set point.
P18	Reset	Parameters are reset to their default setting. The positioner can only return to closed-loop operation after it has been re-initialized.
P19	Enable configuration [LOCK]/OPEN	Enable configuration to change parameter settings. This function is automatically canceled when none of the keys are touched within three minutes.
P20	Firmware version	Installed firmware version is displayed. Touch * to display the last four digits of the serial number.



EU Konformitätserklärung / EU Declaration of Conformity / Déclaration UE de conformité

Die alleinige Verantwortung für die Ausstellung dieser Konformitätserklärung trägt der Hersteller/
This declaration of conformity is issued under the sole responsibility of the manufacturer/
La présente déclaration de conformité est établie sous la seule responsabilité du fabricant.
Für das folgende Produkt / For the following product / Nous certifions que le produit

Elektropneumatischer Stellungsregler / Electropneumatic Positioner / Positionneur électropneumatique Typ/Type/Type 3725

wird die Konformität mit den einschlägigen Harmonisierungsrechtsvorschriften der Union bestätigt/
the conformity with the relevant Union harmonisation legislation is declared with/
est conforme à la législation d'harmonisation de l'Union applicable selon les normes:

EMC 2014/30/EU

EN 61000-6-2:2005, EN 61000-6-3:2007
+A1:2011, EN 61326-1:2013

RoHS 2011/65/EU

EN 50581:2012

Hersteller / Manufacturer / Fabricant:

SAMSON AKTIENGESELLSCHAFT
Weismüllerstraße 3
D-60314 Frankfurt am Main
Deutschland/Germany/Allemagne

Frankfurt / Francfort, 2017-07-29

Im Namen des Herstellers/ On behalf of the Manufacturer/ Au nom du fabricant.

Hanno Zager
Leiter Qualitätssicherung/Head of Quality Management/
Responsable de l'assurance de la qualité

Dirk Hoffmann
Zentralabteilungsleiter/Head of Department/Chef du département
Entwicklungsorganisation/Development Organization



EU Konformitätserklärung / EU Declaration of Conformity / Déclaration UE de conformité

Die alleinige Verantwortung für die Ausstellung dieser Konformitätserklärung trägt der Hersteller/
This declaration of conformity is issued under the sole responsibility of the manufacturer/
La présente déclaration de conformité est établie sous la seule responsabilité du fabricant.
Für das folgende Produkt / For the following product / Nous certifions que le produit

Elektropneumatischer Stellungsregler / Electropneumatic Positioner / Positionneur électropneumatique Typ/Type/Type 3725-1100..

- entsprechend der EU-Baumusterprüfbescheinigung PTB 11 ATEX 2020 X ausgestellt von der/
according to the EU Type Examination PTB 11 ATEX 2020 X issued by/
établi selon le certificat CE d'essais sur échantillons PTB 11 ATEX 2020 X émis par:

Physikalisch Technische Bundesanstalt
Bundesallee 100
D-38116 Braunschweig
Benannte Stelle/Notified Body/Organisme notifié 0102

- wird die Konformität mit den einschlägigen Harmonisierungsrechtsvorschriften der Union bestätigt /
the conformity with the relevant Union harmonisation legislation is declared with/
est conforme à la législation d'harmonisation de l'Union applicable selon les normes:

EMC 2014/30/EU	EN 61000-6-2:2005, EN 61000-6-3:2007 +A1:2011, EN 61326-1:2013
Explosion Protection 94/9/EC (bis/to 2016-04-19) Explosion Protection 2014/34/EU (ab/from 2016-04-20)	EN 60079-0:2009, EN 60079-11:2012
RoHS 2011/65/EU	EN 50581:2012

Hersteller / Manufacturer / Fabricant:

SAMSON AKTIENGESELLSCHAFT
Weismüllerstraße 3
D-60314 Frankfurt am Main
Deutschland/Germany/Allemagne

Frankfurt / Francfort, 2017-07-29

Im Namen des Herstellers/ On behalf of the Manufacturer/ Au nom du fabricant.

Hanno Zager
Leiter Qualitätssicherung/Head of Quality Management/
Responsable de l'assurance de la qualité

Dirk Hoffmann
Zentralabteilungsleiter/Head of Department/Chef du département
Entwicklungsorganisation/Development Organization



(1) **EU-TYPE EXAMINATION CERTIFICATE**
(Translation)

- (2) Equipment or Protective Systems Intended for Use in Potentially Explosive Atmospheres - **Directive 2014/34/EU**
(3) EU-Type Examination Certificate Number:

PTB 11 ATEX 2020 X

Issue: 1

- (4) Product: e/p-positioner, type 3725-1100..
(5) Manufacturer: SAMSON AG
(6) Address: Weismüllerstraße 3, 60314 Frankfurt, Germany
(7) This product and any acceptable variation thereto is specified in the schedule to this certificate and the documents therein referred to.
(8) The Physikalisch-Technische Bundesanstalt, notified body No. 0102 in accordance with Article 17 of the Directive 2014/34/EU of the European Parliament and of the Council, dated 26 February 2014, certifies that this product has been found to comply with the Essential Health and Safety Requirements relating to the design and construction of products intended for use in potentially explosive atmospheres, given in Annex II to the Directive.

The examination and test results are recorded in the confidential Test Report PTB Ex 19-29022.

- (9) Compliance with the Essential Health and Safety Requirements has been assured by compliance with:
EN 60079-0:2012 + A11:2013 EN 60079-11:2012
(10) If the sign "X" is placed after the certificate number, it indicates that the equipment is subject to the Specific Conditions of Use specified in the schedule to this certificate.
(11) This EU-Type Examination Certificate relates only to the design and construction of the specified product in accordance to the Directive 2014/34/EU. Further requirements of the Directive apply to the manufacturing process and supply of this product. These are not covered by this certificate.
(12) The marking of the product shall include the following:

 **II 2 G Ex ia IIC T4 Gb**

Konformitätsbewertungsstelle - Sektor Explosionsschutz Braunschweig, February 25, 2019
On behalf of PTB:

Dr.-Ing. F. Lienesch
Direktor und Professor



ZSEX001e c

sheet 1/3

EU-Type Examination Certificates without signature and official stamp shall not be valid. The certificates may be circulated only without alteration. Extracts or alterations are subject to approval by the Physikalisch-Technische Bundesanstalt. In case of dispute, the German text shall prevail.

Physikalisch-Technische Bundesanstalt • Bundesallee 100 • 38116 Braunschweig • GERMANY

(13)

SCHEDULE

(14) **EU-Type Examination Certificate Number PTB 11 ATEX 2020 X, Issue: 1**

(15) Description of Product

The e/p-positioner, type 3725-1100.. is a single-acting positioner intended for the installation onto pneumatic lift drives and slewing-motion actuators. It is used for the assignment of a valve position to an actuating signal. Non-flammable media serve as pneumatic auxiliary power.

The e/p-positioner, type 3725-1100.. is a passive two-terminal network which may be connected to all certified intrinsically safe circuits provided that the permissible maximum values for U_i , I_i and P_i are not exceeded.

The equipment is installed inside the hazardous area.

The permissible ambient temperature range is -25 °C ... 80 °C.

Electrical data

Signal circuit type of protection Intrinsic Safety Ex ia IIC
 (terminals 11/12) only for connection to a certified intrinsically safe circuit

Maximum values:

$U_i = 28 \text{ V}$

$I_i = 115 \text{ mA}$

$P_i = 1 \text{ W}$

$C_i = 8,3 \text{ nF}$

L_i negligibly low

(16) Test Report PTB Ex 19-29022

(17) Specific conditions of use

The manufacturer documentation and the operating instructions manual shall include all required information to restrict the risk of electrostatic charge to a minimum. A warning label shall be affixed to the equipment.

sheet 2/3

EU-Type Examination Certificates without signature and official stamp shall not be valid. The certificates may be circulated only without alteration. Extracts or alterations are subject to approval by the Physikalisch-Technische Bundesanstalt. In case of dispute, the German text shall prevail.

Physikalisch-Technische Bundesanstalt • Bundesallee 100 • 38116 Braunschweig • GERMANY

SCHEDULE TO EU-TYPE EXAMINATION CERTIFICATE PTB 11 ATEX 2020 X, Issue: 1

(18) Essential health and safety requirements

Met by compliance with the aforementioned standards.

According to Article 41 of Directive 2014/34/EU, EC-type examination certificates which have been issued according to Directive 94/9/EC prior to the date of coming into force of Directive 2014/34/EU (April 20, 2016) may be considered as if they were issued already in compliance with Directive 2014/34/EU. By permission of the European Commission supplements to such EC-type examination certificates and new issues of such certificates may continue to hold the original certificate number issued before April 20, 2016.

Konformitätsbewertungsstelle / Sektor Explosionsschutz
On behalf of PTB:

Braunschweig, February 25, 2019

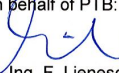
Dr.-Ing. F. Lienesch
Direktor und Professor



sheet 3/3

EU-Type Examination Certificates without signature and official stamp shall not be valid. The certificates may be circulated only without alteration. Extracts or alterations are subject to approval by the Physikalisch-Technische Bundesanstalt. In case of dispute, the German text shall prevail.

Physikalisch-Technische Bundesanstalt • Bundesallee 100 • 38116 Braunschweig • GERMANY

Installation Manual for Apparatus certified by CSA for use in Hazardous Locations

Electrical rating of Intrinsically Safe Apparatus for installation in Hazardous Locations

Table 1: Maximum values

Signal Circuit / Circuit No. 1 Connection to terminals +11 / -12		
Type of protection:		Intrinsically Safe, AEx ia, Nonincendive
Rated current:		4 mA to 20 mA
Maximum values	V_{max} / U_i	28 V
	I_{max} / I_i	115 mA
	P_i	1 W
	C_i	8.3 nF
	L_i	negligible
Software Limit Switches / Circuit No. 2 and 3 Connection to terminals +41 / -42 and +51 / -52		
Type of protection:		Intrinsically Safe, AEx ia, Nonincendive
Rated values:		For connection to NAMUR switching amplifier acc. to IEC 60947-5-6
Maximum values	V_{max} / U_i	20 V
	I_{max} / I_i	60 mA
	P_i	250 mW
	C_i	negligible
	L_i	negligible

Note: Entity / Nonincendive Wiring Parameters must meet the following requirements:

$$U_0 \text{ or } V_{OC} \leq U_i \text{ or } V_{max} / I_0 \text{ or } I_{SC} \leq I_i \text{ or } I_{max} / P_0 \leq P_i \text{ or } P_{max}$$

$$C_a \text{ or } C_O \geq C_i + C_{Cable} / L_a \text{ or } L_O \geq L_i + L_{Cable}$$

The correlation between Temperature Class and permissible ambient temperature range is shown in Table 2.

Table 2:

Temperature Class	Permissible ambient temperature T_a
T4	$-25\text{ °C} \leq T_a \leq +80\text{ °C}$

Intrinsically Safe when installed as specified in manufacturer's Installation Manual.

CSA – certified for Hazardous Locations

Ex ia IIC T4, Class I, Zone 0

AEx ia IIC T4, Class I, Zone 0

Class I, Division 1, Groups A, B, C, D

IP66

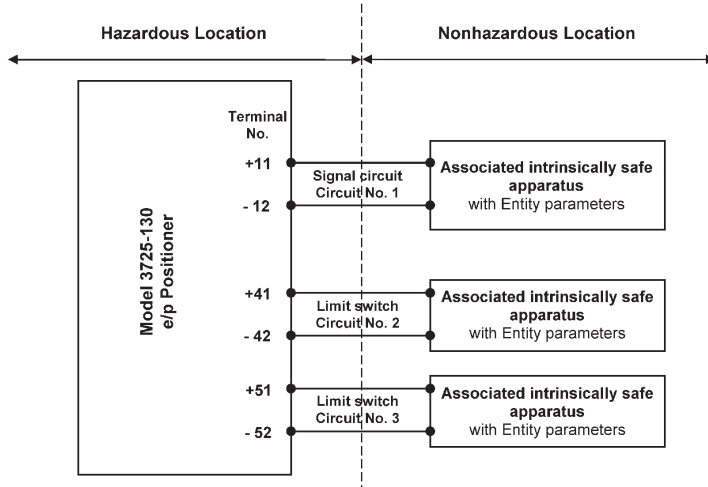

Notes:

1. The apparatus may be installed in intrinsically safe circuits only when used in conjunction with certified intrinsically safe associated apparatus. For maximum values see Table 1 on page 1.
2. For the interconnection of intrinsically safe and associated intrinsically safe apparatus not specifically examined in combination as a system, the Entity Parameters must meet following requirements:

$$\begin{aligned}
 V_{OC} \text{ or } U_0 &\leq U_i \text{ or } V_{max} \\
 I_{SC} \text{ or } I_0 &\leq I_i \text{ or } I_{max} \\
 P_0 &\leq P_i \text{ or } P_{max} \\
 C_a \text{ or } C_0 &\geq C_i + C_{Cable} \\
 L_a \text{ or } L_0 &\geq L_i + L_{Cable}
 \end{aligned}$$

3. The installation must be in accordance with Canadian Electrical Code C.E.C. Part 1.
4. The installation must be in accordance with the National Electrical Code NFPA 70 and ANSI/ISA RP 12.06.01.
5. Due to the high surface resistance avoid electrostatic charging of the enclosure when mounting and servicing the apparatus in hazardous areas.
6. Use only supply wires suitable for 5 °C above surrounding temperature.

CSA – certified for Hazardous Locations
 Class I, Division 2, Groups A, B, C, D
 IP66

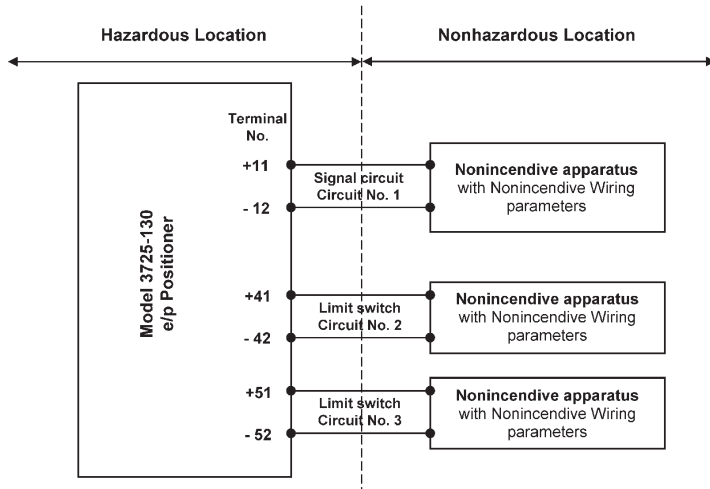

Notes:

- The apparatus may be installed in nonincendive wiring circuits only when used in conjunction with certified nonincendive associated apparatus. For maximum values see Table 1 on Page 1.
- For the interconnection of nonincendive and associated nonincendive apparatus not specifically examined in combination as a system, the Nonincendive Wiring parameters must meet following requirements:

V_{OC} or U_0	\leq	U_i or V_{max}
I_{SC} or I_0	\leq	I_i or I_{max}
P_0	\leq	P_i or P_{max}
C_a or C_O	\geq	$C_i + C_{Cable}$
L_a or L_O	\geq	$L_i + L_{Cable}$
- The installation must be in accordance with Canadian Electrical Code C.E.C. Part 1.
- The installation must be in accordance with the National Electrical Code NFPA 70 and ANSI/ISA RP 12.06.01.
- Due to the non-metallic enclosure make sure to install and service the device:
 - in such a way that electrostatic charging cannot take place,
 - in such a way that the enclosure is protected from mechanical impact.
- Use only supply wires suitable for 5 °C above surrounding temperature.
- Any hazard that could be caused in the valve by the process medium, the signal pressure or by moving parts are to be prevented by means of the appropriate measures.

EB 8394 EN



SAMSON AKTIENGESELLSCHAFT

Weismüllerstraße 3 · 60314 Frankfurt am Main, Germany

Phone: +49 69 4009-0 · Fax: +49 69 4009-1507

samson@samsongroup.com · www.samsongroup.com