

MOUNTING AND OPERATING INSTRUCTIONS



EB 8484-3 EN

Translation of original instructions



TROVIS 3730-3 Smart Positioner (HART®)

HV 02.00.00 · SV 02.02.xx

CE Ex
certified

Edition July 2025

Note on these mounting and operating instructions

These mounting and operating instructions assist you in mounting and operating the device safely. The instructions are binding for handling SAMSON devices. The images shown in these instructions are for illustration purposes only. The actual product may vary.

- For the safe and proper use of these instructions, read them carefully and keep them for later reference.
- If you have any questions about these instructions, contact SAMSON's After-sales Service (aftersaleservice@samsongroup.com).



Documents relating to the device, such as the mounting and operating instructions, are available on our website at www.samsongroup.com > **Downloads > Documentation.**

Definition of signal words

DANGER

Hazardous situations which, if not avoided, will result in death or serious injury

WARNING

Hazardous situations which, if not avoided, could result in death or serious injury

NOTICE

Property damage message or malfunction

Note

Additional information

Tip

Recommended action

1	Safety instructions and measures	1-1
1.1	Notes on possible severe personal injury	1-3
1.2	Notes on possible personal injury	1-4
1.3	Notes on possible property damage	1-5
1.4	Special instructions concerning explosion protection	1-6
1.5	Warnings on the device.....	1-7
2	Markings on the device	2-1
2.1	Nameplate	2-1
2.2	Options.....	2-1
2.3	Firmware versions	2-2
2.4	Hardware versions	2-2
2.5	Article code.....	2-2
3	Design and principle of operation	3-1
3.1	Additional equipment.....	3-1
3.1.1	Optional additional functions.....	3-3
3.2	Mounting versions.....	3-4
3.3	Configuration using the TROVIS-VIEW software	3-5
3.4	Technical data	3-6
3.5	Dimensions in mm.....	3-11
3.6	Fixing levels according to VDI/VDE 3845 (September 2010)	3-15
4	Shipment and on-site transport	4-1
4.1	Accepting the delivered goods	4-1
4.2	Removing the packaging from the positioner	4-1
4.3	Transporting the positioner.....	4-1
4.4	Storing the positioner	4-1
5	Installation	5-1
5.1	Installation conditions	5-1
5.2	Preparation for installation.....	5-2
5.3	Turning the positioner shaft	5-2
5.4	Adjusting the lever and pin position.....	5-2
5.4.1	Travel tables	5-4
5.5	Installing a volume restriction	5-5
5.6	Positioner attachment	5-6
5.6.1	Direct attachment	5-6
5.6.2	Attachment according to IEC 60534-6.....	5-8
5.6.3	Attachment to Type 3510 Micro-flow Valve	5-12
5.6.4	Attachment according to VDI/VDE 3847-1	5-14

Contents

5.6.5	Attachment according to VDI/VDE 3847-2	5-19
5.6.6	Attachment according to VDI/VDE 3845	5-26
5.6.7	Reversing amplifier for double-acting actuators	5-30
5.6.8	Attaching positioners with stainless steel housings	5-30
5.6.9	Air purging function for single-acting actuators	5-31
5.7	Establishing pneumatic connections	5-32
5.7.1	Supply air	5-32
5.7.2	Signal pressure connection	5-33
5.7.3	Output signal display	5-33
5.7.4	Supply pressure	5-33
5.8	Establishing electrical connections	5-34
5.8.1	Cable entry with cable gland	5-35
5.8.2	Electrical power	5-35
5.8.3	Establishing HART® communication	5-42
5.8.4	Switching amplifier according to EN 60947-5-6	5-42
5.9	Accessories	5-44
6	Operation	6-1
6.1	Rotary pushbutton	6-1
6.2	AIR TO OPEN/AIR TO CLOSE slide switch	6-2
6.3	Initialization key (INIT)	6-2
6.4	Display	6-3
6.4.1	Display icons	6-5
7	Start-up and configuration	7-1
7.1	First start-up	7-2
7.2	Start-up settings	7-3
7.3	Enabling configuration to change parameters	7-3
7.4	Start-up menu	7-4
7.4.1	Setting the actuator type	7-4
7.4.2	Determining the fail-safe position	7-4
7.4.3	Specifying the pin position	7-5
7.4.4	Setting the nominal range	7-5
7.4.5	Selecting the initialization mode	7-6
7.4.6	Setting the initialization mode	7-7
7.5	Initializing the positioner	7-9
7.6	Adjusting the switching points	7-11
7.6.1	Adjusting switching position 1 (e.g. closed valve)	7-12
7.6.2	Adjusting switching position 2 (e.g. open valve)	7-12

8	Operation	8-1
8.1	Changing the reading direction of the display	8-1
8.2	HART® communication	8-2
8.2.1	Dynamic HART® variables	8-2
8.3	Changing operating mode	8-6
8.4	Performing zero calibration	8-6
8.5	Resetting the positioner	8-7
9	Malfunctions	9-1
9.1	Emergency action	9-6
10	Servicing	10-1
10.1	Cleaning the cover window	10-1
10.2	Firmware updates	10-2
10.3	Periodic inspection and testing of the positioner	10-2
11	Decommissioning	11-1
12	Removal	12-1
13	Repairs	13-1
13.1	Servicing explosion-protected devices	13-1
13.2	Returning devices to SAMSON	13-1
14	Disposal	14-1
15	Certificates	15-1
16	Appendix A (configuration instructions)	16-1
16.1	Code list	16-1
16.1.1	Start screen	16-1
16.1.2	Main menu and start-up	16-2
16.1.3	Process data	16-27
16.1.4	Diagnosis/maintenance	16-28
16.1.5	Diagnosis: status messages	16-37
16.1.6	Reset functions	16-42
16.1.7	Display start-up	16-43
16.2	Behavior of menu items when reset functions are used	16-44
16.3	Valve characteristic selection	16-54
17	Appendix B	17-1
17.1	After-sales service	17-1

1 Safety instructions and measures

Intended use

The SAMSON TROVIS 3730-3 Positioner is mounted on pneumatic control valves and used to assign the valve position to the control signal. The device is designed to operate under exactly defined conditions (e.g. operating pressure, temperature). Therefore, operators must ensure that the positioner is only used in applications where the operating conditions correspond to the technical data. In case operators intend to use the positioner in applications or conditions other than those specified, contact SAMSON.

SAMSON does not assume any liability for damage resulting from the failure to use the device for its intended purpose or for damage caused by external forces or any other external factors.

➔ Refer to the technical data for limits and fields of application as well as possible uses.

Reasonably foreseeable misuse

The TROVIS 3730-3 Positioner is **not** suitable for the following applications:

- Use outside the limits defined during sizing and by the technical data

Furthermore, the following activities do not comply with the intended use:

- Use of non-original spare parts
- Performing maintenance activities not described in these instructions

Qualifications of operating personnel

The positioner must be mounted, started up and serviced by fully trained and qualified personnel only; the accepted industry codes and practices must be observed. According to these mounting and operating instructions, trained personnel refers to individuals who are able to judge the work they are assigned to and recognize possible hazards due to their specialized training, their knowledge and experience as well as their knowledge of the applicable standards.

Explosion-protected versions of this device must be operated only by personnel who has undergone special training or instructions or who is authorized to work on explosion-protected devices in hazardous areas.

Safety instructions and measures

Personal protective equipment

No personal protective equipment is required for the direct handling of the positioner. Work on the control valve may be necessary when mounting or removing the device.

- Observe the requirements for personal protective equipment specified in the valve documentation.
- Check with the plant operator for details on further protective equipment.

Revisions and other modifications

Revisions, conversions or other modifications of the product are not authorized by SAMSON. They are performed at the user's own risk and may lead to safety hazards, for example. Furthermore, the product may no longer meet the requirements for its intended use.

Safety features

Upon failure of the air supply and/or electrical signal, the positioner vents the actuator, causing the valve to move to the fail-safe position determined by the actuator.

Warning against residual hazards

The positioner has direct influence on the control valve. To avoid personal injury or property damage, plant operators and operating personnel must prevent hazards that could be caused in the control valve by the process medium, the operating pressure, the signal pressure or by moving parts by taking appropriate precautions. Plant operators and operating personnel must observe all hazard statements, warnings and caution notes in these mounting and operating instructions, especially for installation, start-up and service work.

If inadmissible motions or forces are produced in the pneumatic actuator as a result of the supply pressure, it must be restricted using a suitable supply pressure reducing station.

Responsibilities of the operator

Operators are responsible for proper use and compliance with the safety regulations. Operators are obliged to provide these mounting and operating instructions to the operating personnel and to instruct them in proper operation. Furthermore, operators must ensure that operating personnel or third parties are not exposed to any danger.

Responsibilities of operating personnel

Operating personnel must read and understand these mounting and operating instructions as well as the specified hazard statements, warnings and caution notes. Furthermore, the operating personnel must be familiar with the applicable health, safety and accident prevention regulations and comply with them.

Referenced standards, directives and regulations

Devices with a CE marking fulfill the following requirements of the Directives:

- TROVIS 3730-3: 2011/65/EU, 2014/30/EU
- TROVIS 3730-3-110/-510/-810: 2011/65/EU, 2014/30/EU, 2014/34/EU

See Appendix for declarations of conformity.

Referenced documents

The following documents apply in addition to these mounting and operating instructions:

- Operating instructions for valve diagnostics: ► EB 8389-3
- The mounting and operating instructions of the components on which the positioner is mounted (valve, actuator, valve accessories etc.).

1.1 Notes on possible severe personal injury

DANGER

Risk of fatal injury due to the formation of an explosive atmosphere.

Incorrect installation, operation or maintenance of the positioner in potentially explosive atmospheres may lead to ignition of the atmosphere and ultimately to death.

- ➔ The following regulations apply to installation in hazardous areas: EN 60079-14 (VDE 0165, Part 1).
- ➔ Installation, operation or maintenance of the positioner is to be performed only by personnel who has undergone special training or instructions or who is authorized to work on explosion-protected devices in hazardous areas.

1.2 Notes on possible personal injury

WARNING

Risk of personal injury due to moving parts on the valve.

During initialization of the positioner and during operation, the valve moves through its entire travel range. Injury to hands or fingers is possible if they are inserted into the valve.

- During initialization, do not insert hands or fingers into the valve yoke and do not touch any moving valve parts.

Sudden loud noise when the pneumatic actuator vents.

The positioner mounted on the control valve can cause the pneumatic actuator to vent. A loud noise may occur during venting. This can cause hearing damage.

- Wear hearing protection when working near the valve.

Incorrect electrical connection will render the explosion protection unsafe.

- Adhere to the terminal assignment.
- Do not undo the enameled screws in or on the housing.

Intrinsic safety rendered ineffective in intrinsically safe devices.

Every time the positioner is operated, even when it is not installed in the plant (e.g. during maintenance, calibration and work on the device), it must be ensured that the conditions for intrinsically safe circuits are observed.

- Only connect intrinsically safe devices intended for use in intrinsically safe circuits to certified intrinsically safe input-connected units.
- Do not place intrinsically safe devices back into operation that were connected to intrinsically safe input-connected units without certification.
- Do not exceed the maximum permissible electric values specified in the EU type examination certificates when interconnecting intrinsically safe electrical equipment (U_i or U_0 , I_i or I_0 , P_i or P_0 , C_i or C_0 and L_i or L_0).

1.3 Notes on possible property damage

NOTICE

Risk of damage to the positioner due to incorrect mounting position.

- Do not mount the positioner with the back of the device facing upward.
- Do not seal or restrict the vent opening when the device is installed on site.

An incorrect electric signal will damage the positioner.

A current source must be used to power the positioner.

- Only use a current source and never a voltage source.

Incorrect assignment of the terminals will damage the positioner and will lead to malfunction.

For the positioner to function properly, the prescribed terminal assignment must be observed.

- Connect the electrical wiring to the positioner according to the prescribed terminal assignment.

Malfunction due to initialization not yet completed.



The initialization causes the positioner to be calibrated to adapt it to the mounting situation. After initialization is completed, the positioner is ready for use.

- Initialize the positioner on first start-up.
- Re-initialize positioner after changing the mounting position.

Risk of positioner damage due to incorrect grounding of the electric welding equipment.

- Do not ground electric welding equipment near the positioner.

Note

Operating the positioner with an open cover may cause the pressure sensor values to change spontaneously due to electrostatic discharge. As a result, error messages indicated by the ,  or  icons may briefly appear on the positioner display. These error messages that briefly appear do not have any effect on the basic control function or integrity of the positioner.

1.4 Special instructions concerning explosion protection

If a part of the device on which the explosion protection is based needs to be serviced, the device must not be put back into operation until a qualified inspector has assessed it according to explosion protection requirements, has issued an inspection certificate, or given the device a mark of conformity. Inspection by a qualified inspector is not required if the manufacturer performs a routine test on the device before putting it back into operation and the passing of the routine test is documented by attaching a mark of conformity to the device. Replace explosion-protected components only with original, routine-tested components by the manufacturer.

Devices that have already been operated outside hazardous areas and are intended for future use inside hazardous areas must comply with the safety requirements placed on serviced devices. Before being operated inside hazardous areas, test the devices according to the specifications for servicing explosion-protected devices.

Maintenance, calibration and work on equipment

- Only use intrinsically safe current/voltage calibrators and measuring instruments for interconnection with intrinsically safe circuits to check or calibrate the equipment inside or outside hazardous areas.
- Observe the maximum permissible values specified in the certificates for intrinsically safe circuits.

Equipment with type of protection Ex ec

- In equipment operated with type of protection Ex ec (increased safety), only connect, isolate or switch circuits while energized during installation, maintenance or repair.
- Use certified cable glands and blanking plugs with appropriate type of protection and IP rating $\geq 6X$ and suitable for the certified temperature range.
- Connect the signal circuit using screw terminals (terminal 11/12) for electrical conductors with a wire cross-section from 0.2 to 2.5 mm². The tightening torque is 0.5 to 0.6 Nm.

Equipment with type of protection Ex ia

- In equipment operated with type of protection Ex ia (intrinsic safety), only connect, isolate or switch circuits while energized during installation, maintenance or repair.
- Do not open the enclosure cover in potentially explosive dust atmospheres during operation.

- For applications in dust group III C, replace the supplied cable glands, blanking plugs and connectors with certified cable glands, blanking plugs and connectors. Only use cable glands, blanking plugs and connectors which are suitable for the certified temperature range and have a minimum IP rating of IP54.
- Connect the signal circuit using screw terminals (terminal 11/12) for electrical conductors with a wire cross-section from 0.2 to 2.5 mm². The tightening torque is 0.5 to 0.6 Nm.

Equipment with type of protection Ex t

- In equipment operated with type of protection Ex t (protection by enclosure), only connect, isolate or switch circuits while energized during installation, maintenance or repair.
- While working on the device during operation in potentially explosive dust atmospheres, be aware that opening the housing cover may cause the explosion protection to become ineffective.
- Use certified cable glands and blanking plugs with appropriate type of protection and IP rating ≥ 6X and suitable for the certified temperature range.
- To connect the signal circuit, use screw terminals (terminal 11/12) for electrical conductors with a wire cross-section from 0.2 to 2.5 mm². The tightening torque is 0.5 to 0.6 Nm.

1.5 Warnings on the device

Warning symbols	Meaning of the warning
	<p>Warning against sudden loud noise The positioner mounted on the control valve can cause the pneumatic actuator to vent. A loud noise may occur during venting. This can cause hearing damage.</p>

2 Markings on the device

2.1 Nameplate

The nameplates shown were up to date at the time of publication of this document. The nameplate on the device may differ from the one shown.

Version without explosion protection

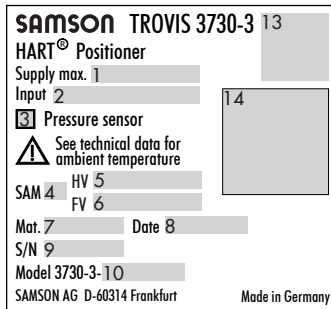

Explosion-protected version

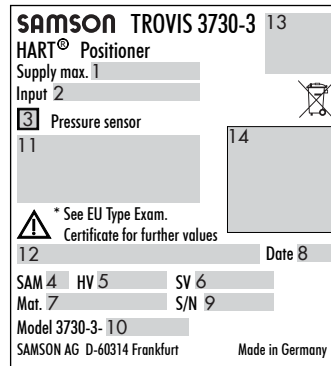

- 1 Supply pressure
- 2 Signal range
- 3 Pressure sensor (yes/no)
- 4 Code for NAMUR Recommendation
NE 53 (internal specification)
- 5 Hardware version
- 6 Software version
- 7 Material number
- 8 Date of manufacture

- 9 Serial number
- 10 Model number
- 11 Type of protection for explosion-protected devices
- 12 Temperature ranges for explosion-protected devices
- 13 Conformity
- 14 DataMatrix code (electronic nameplate)

2.2 Options

If option modules are installed in the TROVIS 3730-3 Positioner, a label to identify the module is affixed to the device:

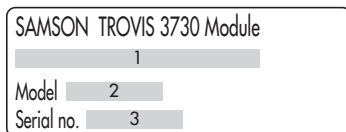

- 1 Option's function
- 2 Model number
- 3 Serial number

Markings on the device

2.3 Firmware versions

Firmware revisions		Associated hardware version
Firmware	Revisions	
02.00.11	–	01.00.00 ¹⁾
02.00.13 ²⁾	Initialization optimized	01.00.00
02.02.12	<ul style="list-style-type: none"> • Course of supply pressure • Pressure limitation • Extended diagnostics • Valve signature: Start condition of reference graph and test with comparison feature • Local password 	02.00.00

1) Upgrading hardware version 01.00.00 to hardware version 02.00.00 not possible

2) Updating firmware version 02.00.13 to firmware version 02.02.12 not possible

2.4 Hardware versions

Hardware revisions	
Hardware	Revisions
01.00.00	–
02.00.00	Pressure sensor option added

2.5 Article code

Positioner	TROVIS 3730-3- x x x 0 x x x x 0 x x x 0 x x x x x x x x x x x																			
With LCD, autotune, HART® communication																				
Explosion protection																				
Without		0	0	0				0/1/4												
	II 2G Ex ia IIC T4/T6 Gb							2/4										0/1		
	II 2D Ex ia IIIC T85 °C Db	1	1	0																
ATEX/IECEx	II 2D Ex tb IIIC T85°C Db	5	1	0				2/4										1		
	II 3G Ex ec IIC T4/T6 Gc							2/4										1		
	II 2D Ex tb IIC T85°C Db	8	1	0																

Positioner	TROVIS 3730-3- x x x 0 x x x x 0 x x x 0 x x x x x x x x x x															
Option A																
Without	0															
Position transmitter 4 to 20 mA	1															
Binary input 24 V DC	2															
Option B																
Without	0															
Binary input 24 V DC	2															
Forced venting	3															
Option C																
Without	0															
2x Software limit switches ¹⁾ + binary output (PLC)	1															
2x Software limit switches ¹⁾ + binary output (NAMUR)	2															
2x Inductive limit switches ¹⁾ + Binary output (NAMUR); -50 to +85 °C	4															
Option D																
Without	0															
Pressure sensors																
Without				0												
Supply 9, Output 38				1									0/1			
Emergency shutdown																
3.8 mA							0									
Electrical connection																
2x M20x1.5 (1x cable gland, 1x blanking plug)								1								
Housing material																
Aluminum EN AC-44300DF (standard)									0							
Stainless steel 1.4408									1							
Cover																
With round window										1						
Without window										2						
Housing version																
Standard											0	0				
With additional vent hole and VDI/VDE 3847 adapter; without travel pick-off parts											2	0				
With additional vent hole											2	1				

Markings on the device

Positioner	TROVIS 3730-3- x x x 0 x x x x 0 x x x 0 x x x x x x x x x x															
Safety approval																
SIL	1															
Type approval for marine applications																
Without	0															
Bureau Veritas	1															
DNV GL	2															
American Bureau of Shipping (ABS)	3															
Lloyd's Register	5															
Permissible ambient temperature																
Standard: -20 to +85 °C	0															
-40 to +85 °C metal cable gland	1															
-55 to +85 °C, low-temperature version with metal cable gland	2															
Hardware version																
HV 01.00.00 ^{2) 3)}											9	9				
HV 02.00.00 ⁴⁾											9	8				
Firmware version																
SV 02.00.15																9 7
SV 02.02.12																9 4

- 1) Software limit switches (PLC) are not available in the explosion-protection version.
- 2) The hardware version 01.00.00 is only compatible with software version 02.00.xx (updating to version 02.02.xx is not possible).
- 3) Information on TROVIS 3730-3 Positioner with hardware version 01.00.xx and software version 02.00.xx can be found in the corresponding Mounting and Operating Instructions ► EB 8484-3 for software version 02.00.xx
- 4) The hardware version 02.00.00 is only compatible with software version 02.02.xx (downdating to version 02.00.xx is not possible).

3 Design and principle of operation

→ See Fig. 3-1

The TROVIS 3730-3 Electropneumatic Positioner is mounted on pneumatic control valves and used to assign the valve position (controlled variable x) to the control signal (set point w). The positioner compares the electric control signal of a control system to the travel or opening angle of the control valve and issues a signal pressure for the pneumatic actuator.

The positioner mainly consists of a non-contact travel sensor system (2), pneumatics and the electronics with the microcontroller (4).

The valve position is transmitted either as an angle of rotation or linear travel to the pick-up lever, from there to the travel sensor (2) and forwarded to the microcontroller (4).

The PID algorithm in the microcontroller compares the valve position measured by the travel sensor (2) to the 4 to 20 mA DC control signal issued by the control system after it has been converted by the A/D converter (3).

In case of a set point deviation, the activation of the i/p converter (7) is changed so that the actuator of the control valve (1) is pressurized or vented accordingly over the downstream air capacity booster (6). As a result, the closure member of the valve (e.g. plug) is moved to the position determined by the set point.

The positioner is operated by a rotary push-button (10) for menu navigation on the plain-text display (11).

The extended EXPERTplus diagnostics are integrated into the positioner. They provide information on the control valve and positioner and generate diagnostic and status messages, which allow faults to be pinpointed quickly.

3.1 Additional equipment

Volume restriction

The volume restriction Q serves to adapt the air output capacity to the size of the actuator.

The volume restriction is screwed into the signal pressure output of the positioner (or output of the pressure gauge bracket or connecting plate).

- SAMSON recommends using a volume restriction (see the 'Installation' chapter).
 - For linear actuators with a transit time < 1 s (e.g. with an actuator area smaller than 240 cm^2),
 - For rotary actuators with a volume of less than 300 cm^3 .
- Actuators with a transit time ≥ 1 s do not require the air flow rate to be restricted.

Design and principle of operation

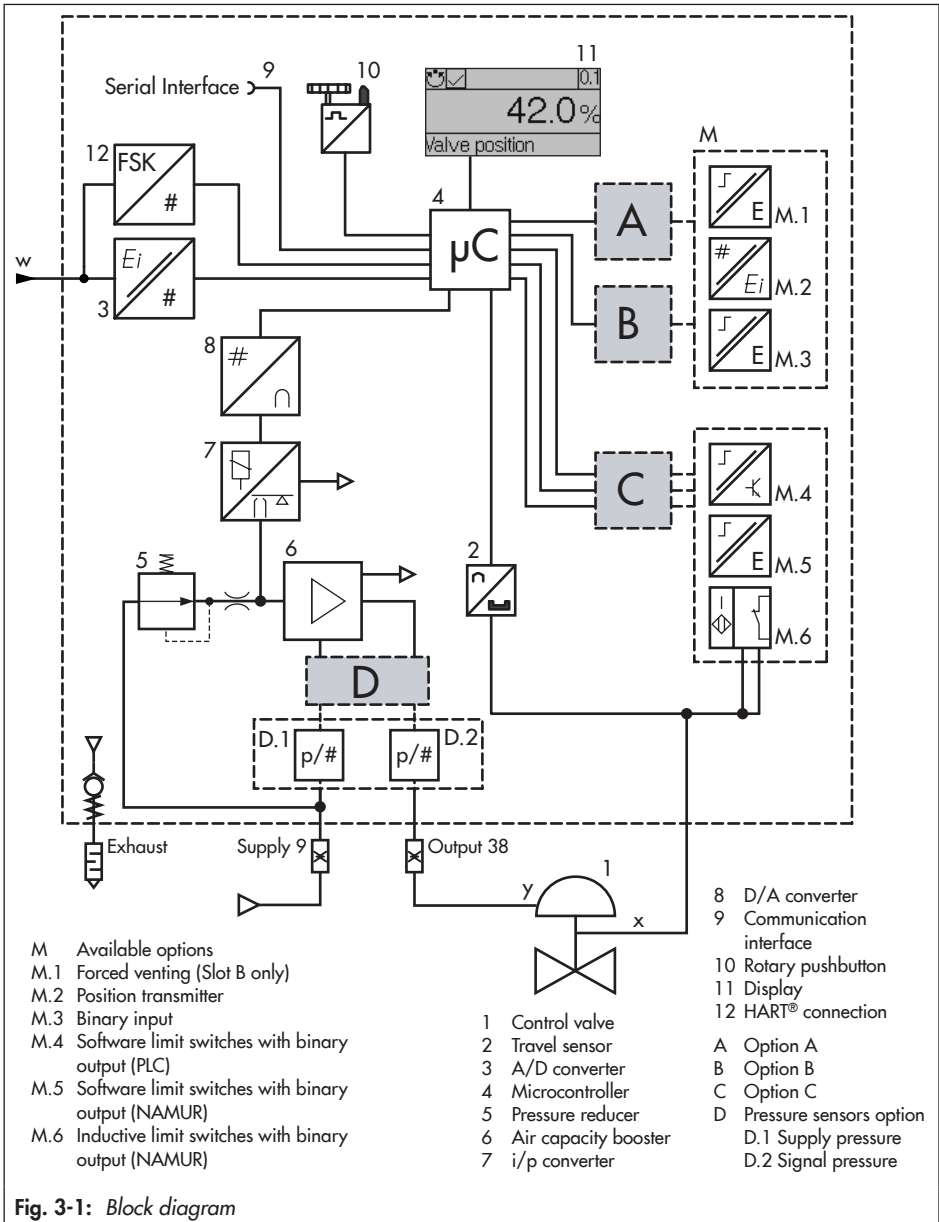

3.1.1 Optional additional functions

i Note

Optional additional functions must be selected at the ordering stage and are ready installed in the delivered positioner. The options can only be exchanged or retrofitted by SAMSON's After-sales Service.

See the 'Installation' chapter for terminal assignment.

Inductive limit switches

Inductive slot sensors issue a signal to a control system when the valve reaches one of the two adjustable limits. They are operated by adjustable tags. For operation of the inductive limit switches, switching amplifiers must be connected in the output circuit.

Software limit switches

The software limit switches signalize that the valve has reached one of the two adjustable limits.

- When limit 1 is not reached
- When limit 2 is exceeded

The following versions are available:

- Version without explosion protection: PLC switches
Connection according to DIN EN 61131-2, $P_{\max} = 400 \text{ mW}$
- Explosion-protected version: NAMUR switches
Connection to switching amplifiers according to EN 60947-5-6

Position transmitter

The position transmitter is a two-wire transmitter and issues the travel sensor signal as a 4 to 20 mA signal processed by the micro-controller. This signal is issued independent of the positioner's input signal. Additionally, the position transmitter allows positioner faults to be indicated over a signal current of $<2.4 \text{ mA}$ or $>21.6 \text{ mA}$.

Forced venting

The positioner either vents the actuator or supplies it with air when the voltage signal at the terminals falls below 11 V. This occurs regardless of the set point. A voltage above 15 V keeps the forced venting function inactive.

Binary input

The binary input can be floating or non-floating (0 to 24 V) and can be configured to provide the following functions:

- **Switching state:** the switching state of the binary input is logged.
- **On-site write protection:** after the first initialization, a local write protection can be activated. While the binary input is active, no settings can be changed at the positioner. The positioner cannot be re-initialized.
- **PST (partial stroke test):** test to check the valve's ability to move and assess its dynamic control response (PST: partial stroke test/FST: full stroke test).
 - **Start PST:** perform a step response test in an adjustable range.

Design and principle of operation

- **Start FST:** perform a step response test over the entire travel range following configurable parameters.
- **Move valve to fixed value:** move the valve to a defined position (valve position in %).

In addition, a binary input can be deactivated.

Binary output

A fault alarm output signalizes a fault to the control station. The following versions are available:

- Version without explosion protection: PLC switches
Connection according to DIN EN 61131-2, $P_{\max} = 400 \text{ mW}$
- Explosion-protected version: NAMUR switches
Connection to switching amplifiers according to EN 60947-5-6

Pressure sensor

Both pressure sensors monitor the supply pressure (sensor D.1) and the signal pressure (sensor D.2). These sensors provide additional diagnostic functions in the positioner that are based on the signal pressure (e.g. the valve signature).

3.2 Mounting versions

The TROVIS 3730-3 Positioner is suitable for the following types of attachment using the corresponding accessories (see the 'Installation' chapter):

- Direct attachment to Type 3277 Actuator
The positioner is mounted on the yoke. The signal pressure is connected to the actuator over a connection block: internally over a hole in the valve yoke for "actuator stem extends" fail-safe action and through an external signal pressure line for "actuator stem retracts" fail-safe action.
- Attachment to actuators according to IEC 60534-6:
The positioner is attached to the control valve using a NAMUR bracket.
- Attachment according to VDI/VDE 3847-1/-2:
Attachment according to VDI/VDE 3847-1/-2 using the corresponding accessories allows the positioner to be replaced quickly while the process is running.
- Attachment to Type 3510 Micro-flow Valve
The positioner is attached to the valve yoke using a bracket.
- Attachment to rotary actuators according to VDI/VDE 3845:
The positioner is mounted to the rotary actuator using the corresponding accessories.

3.3 Configuration using the TROVIS-VIEW software

The positioner can be configured with SAMSON's TROVIS-VIEW Software (version 4). For this purpose, the positioner has a digital interface (**SAMSON SERIAL INTERFACE, SSP**) to allow the USB port of a computer to be connected to it using an adapter cable. We do not recommend using the RS-232 interface on a computer (e.g. through the use of an additional USB/RS-232 adapter) due to performance reasons.

The TROVIS-VIEW software enables the user to easily configure the positioner as well as view process parameters online.

i Note

TROVIS-VIEW provides a uniform user interface that allows users to configure and parameterize various SAMSON devices using device-specific database modules. The 3730-3 device module can be downloaded free of charge from our website at

► www.samsongroup.com > Downloads > Software & Drivers > TROVIS-VIEW.

Further information on TROVIS-VIEW (e.g. system requirements) is available on our website and in the Data Sheet ► T 6661 .

3.4 Technical data

Table 3-1: TROVIS 3730-3 Electropneumatic Positioner

Travel	
Adjustable travel/ range of rotation for	Linear actuators: Direct attachment to Type 3277 3.6 to 30 mm Attachment according to IEC 60534-6 (NAMUR) 3.6 to 300 mm Attachment according to VDI/VDE 3847-1 3.6 to 300 mm Rotary actuators: Attachment according to VDI/VDE 3845/3847-2: 24 to 100°
Travel range	Adjustable within the initialized travel/angle of rotation of the valve; travel can be restricted to 1/5 at the maximum.
Set point w	
Signal range	4 to 20 mA · Two-wire device, reverse polarity protection · Minimum span 4 mA
Static destruction limit	40 V, internal current limit approx. 40 mA
Minimum current	3.75 mA for display/operation (HART® communication and configuration) 3.90 mA for pneumatic function
Load impedance	≤9.3 V (corresponds to 465 Ω at 20 mA)
Supply	
Supply air	1.4 to 7 bar (20 to 105 psi)
Air quality acc. to ISO 8573-1	Max. particle size and density: Class 4 Oil content: Class 3 Pressure dew point: Class 3 or at least 10 K below the lowest ambient temperature to be expected
Signal pressure (output)	0 bar up to supply pressure Can be limited to 1.4 bar/2.4 bar/3.7 bar/4.7 bar ±0.2 bar by software
Hysteresis	≤0.3 %
Sensitivity	≤0.1 %
Characteristic	Linear/Equal percentage/Reverse equal percentage/SAMSON butterfly valve
Transit time	Exhaust and supply adjustable separately up to 240 s by software
Direction of action	Reversible
Air consumption, steady state	Independent of supply air, approx. 65 l _n /h

Air output capacity (when $\Delta p = 6 \text{ bar}$)	
Actuator (supply)	$8.5 \text{ m}_n^3/\text{h} \cdot \text{At } \Delta p = 1.4 \text{ bar: } 3.0 \text{ m}_n^3/\text{h} \cdot K_{V_{\max}(20^\circ\text{C})} = 0.09$ – At the signal pressure output (38) (connecting plate or connection block): can be restricted to $K_{V_{\max}(20^\circ\text{C})} \approx 1/3 K_{V_{\max}(20^\circ\text{C})}$ – At the signal pressure output on the back: $K_{V_{\max}(20^\circ\text{C})} \approx 1/3 K_{V_{\max}(20^\circ\text{C})}$
Actuator (exhaust)	$14.0 \text{ m}_n^3/\text{h} \cdot \text{At } \Delta p = 1.4 \text{ bar: } 4.5 \text{ m}_n^3/\text{h} \cdot K_{V_{\max}(20^\circ\text{C})} = 0.15$ – At the signal pressure output (38) (connecting plate or connection block): can be restricted to $K_{V_{\max}(20^\circ\text{C})} \approx 1/3 K_{V_{\max}(20^\circ\text{C})}$ – At the signal pressure output on the back: $K_{V_{\max}(20^\circ\text{C})} \approx 1/3 K_{V_{\max}(20^\circ\text{C})}$
Environmental conditions and permissible temperatures	
Permissible environmental conditions according to EN 60721-3	
Storage	1K6 (relative humidity $\leq 95\%$)
Transport	2K4
Operation	–20 to +85 °C: All versions –40 to +85 °C: With metal cable glands –55 to +85 °C: Low-temperature version with metal cable glands Observe the limits in the test certificate for explosion-protected versions.
Resistance to vibration	
Vibrations (sinusoidal)	According to DIN EN 60068-2-6: 0.15 mm, 10 to 60 Hz; 20 m/s ² , 60 to 500 Hz per axis 0.75 mm, 10 to 60 Hz; 100 m/s ² , 60 to 500 Hz per axis
Bumps (half sine)	According to DIN EN 60068-2-29: 150 m/s ² , 6 ms; 4000 bumps per axis
Noise	According to DIN EN 60068-2-64: 10 to 200 Hz: 1 (m/s ²) ² /Hz 200 to 500 Hz: 0.3 (m/s ²) ² /Hz 4 h/axis
Recommended continuous duty	$\leq 20 \text{ m/s}^2$
Influences	
Temperature	$\leq 0.15\% / 10 \text{ K}$
Supply	None
Requirements	
EMC	Complying with EN 61000-6-2, EN 61000-6-3, EN 61326-1 and NAMUR Recommendation NE 21
Degree of protection	IP66

Design and principle of operation

Electrical connections	
Cable glands	One M20x1.5 cable gland for 6 to 12 mm clamping range Second M20x1.5 threaded connection additionally available
Terminals	Screw terminals for 0.2 to 2.5 mm ² wire cross-section
Explosion protection	
ATEX, IECEx, ...	See Table 3-3
Materials	
Housing and cover	Die-cast aluminum EN AC-ALSi12(Fe) (EN AC-44300) acc. to DIN EN 1706, chromate and powder coating · Special version: stainless steel 1.4408
Window	Makrolon® 2807
Cable glands	Polyamide, nickel-plated brass, stainless steel 1.4305
Other external parts	Stainless steel: 1.4571 and 1.4301
Communication	
	TROVIS VIEW with SSP/HART® Revision 7
Weight	
	Aluminum housing: approx. 1.0 kg · Stainless steel housing: approx. 2.2 kg

Table 3-2: *Optional additional functions*

Position transmitter	
Version	Two-wire system, galvanic isolation, reverse polarity protection, reversible direction of action
Supply	10 to 30 V DC
Output signal	4 to 20 mA
Error indication	2.4 or 21.6 mA
No-load current	1.4 mA
Static destruction limit	38 V DC · 30 V AC

Software limit switches	NAMUR (explosion-protected version of TROVIS 3730-3)	PLC (non-explosion-protected version of TROVIS 3730-3)
Version	Galvanic isolation, reverse polarity protection, switching output acc. to EN 60947-5-6	Galvanic isolation, reverse polarity protection, binary input of a PLC acc. to EN 61131-2, $P_{max} = 400 \text{ mW}$
Signal state	$\leq 1.0 \text{ mA}$ (non-conducting)	$R = 10 \text{ k}\Omega$ (non-conducting)
	$\geq 2.2 \text{ mA}$ (conducting)	$R = 348 \Omega$ (conducting)
Static destruction limit	32 V DC/24 V AC	32 V DC/50 mA
Binary output	NAMUR (explosion-protected version of TROVIS 3730-3)	PLC (non-explosion-protected version of TROVIS 3730-3)
Version	Galvanic isolation, reverse polarity protection, switching output acc. to EN 60947-5-6	Galvanic isolation, reverse polarity protection, binary input of a PLC acc. to EN 61131-2, $P_{max} = 400 \text{ mW}$
Signal state	$\leq 1.0 \text{ mA}$ (non-conducting)	$R = 10 \text{ k}\Omega$ (non-conducting)
	$\geq 2.2 \text{ mA}$ (conducting)	$R = 348 \Omega$ (conducting)
Static destruction limit	32 V DC/24 V AC	32 V DC/50 mA
Inductive limit switches		
Version	For connection to switching amplifier according to EN 60947-5-6, SJ2-SN proximity switches (P+F 70133004), reverse polarity protection	
Measuring plate not detected	$\geq 3 \text{ mA}$	
Measuring plate detected	$\leq 1 \text{ mA}$	
Static destruction limit	20 V DC	
Permissible ambient temperature	$-50 \text{ to } +85 \text{ }^\circ\text{C}$	
Binary input (switching behavior configured in TROVIS-VIEW software)		
Active switching behavior (default setting)		
Connection	For external switch (floating contact) or relay contact	
Open-circuit voltage	Max. 10 V (when contact is open)	
Current draw	Max. 100 mA (pulsed when contact is closed)	
Contact	Closed: $R < 20 \Omega$; open: $R > 400 \Omega$	

Design and principle of operation

Passive switching behavior		
Connection	For externally applied DC voltage, reverse polarity protection	
Voltage input	0 to 30 V	
Static destruction limit	40 V DC	
Current draw	3.7 V at 24 mA	
Switching voltage	Closed: <1 V; open: >6 V	
Forced venting		
Version	Galvanic isolation, reverse polarity protection	
Voltage input	0 to 24 V DC	
Input resistance	$\geq 7 \text{ k}\Omega$	
Signal state	Active	$U_e < 11 \text{ V}$
	Not active	$U_e > 15 \text{ V}$
Static destruction limit	38 V DC/30 V AC	
Pressure sensors		
Pressure range	0 to 7 bar	
Permissible temperature range	-40 to +85 °C	

Table 3-3: Summary of explosion protection approvals

TROVIS 3730-3-	Certification	Type of protection/comments	
		Number	Date
-110	ATEX/IECEX	BVS 18 ATEX E 044 X 2025-02-21	II 2G Ex ia IIC T4/T6 Gb II 2D Ex ia IIIC T85 °C Db
-510	ATEX/IECEX	BVS 18 ATEX E 044 X 2025-02-21	II 2D Ex tb IIIC T85°C Db or II 2D Ex tb IIIC T85°C Db and II 3G Ex ec IIC T4/T5 Gc
-810	ATEX/IECEX	BVS 18 ATEX E 044 X 2025-02-21	II 3G Ex ec IIC T4/T6 Gc II 2D Ex tb IIC T85°C Db

3.5 Dimensions in mm

Attachment according to IEC 60534-6

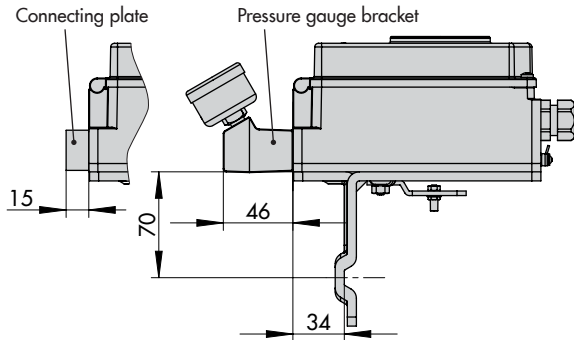

Direct attachment

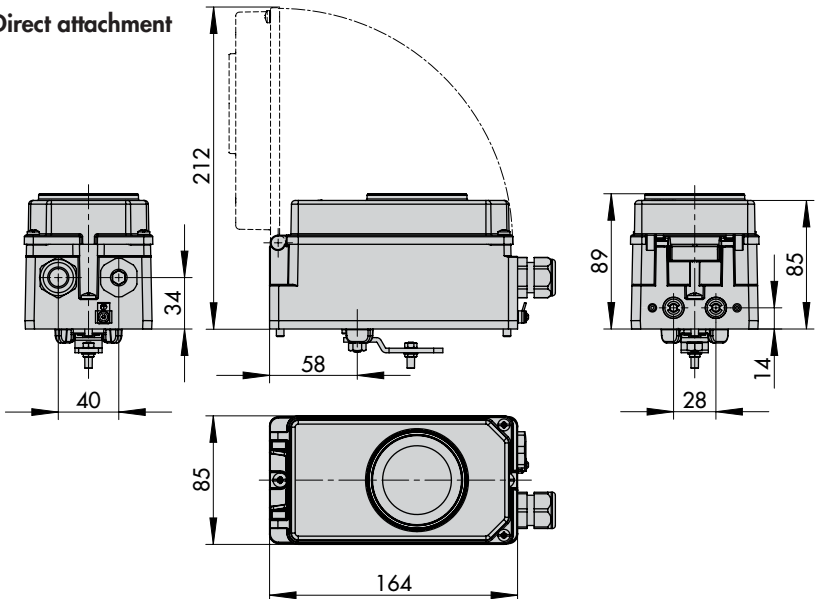

**Attachment according to VDI/
VDE 3847-1 onto Type 3277
Actuator**

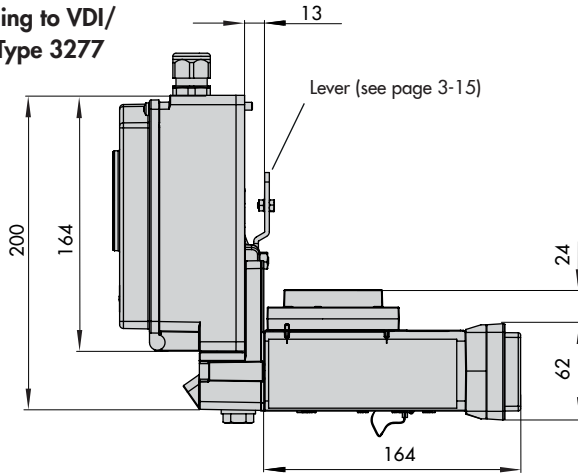

**Attachment according to VDI/
VDE 3847-1 to a NAMUR rib**

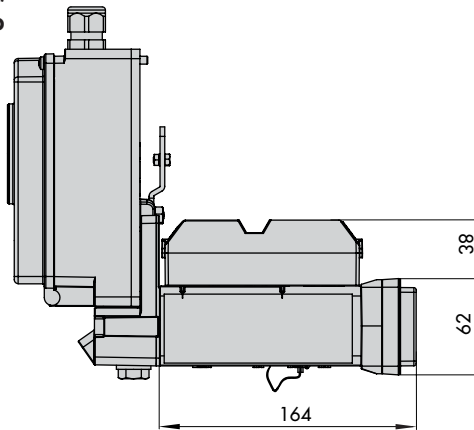

**Attachment according to VDI/VDE 3847-2 with
single-acting actuator**

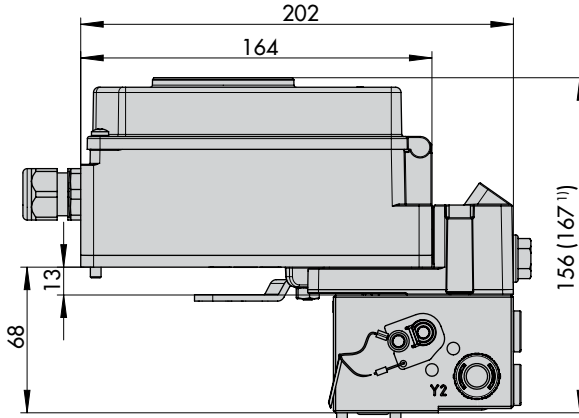

**Attachment according to VDI/VDE 3847-2 with
double-acting actuator**

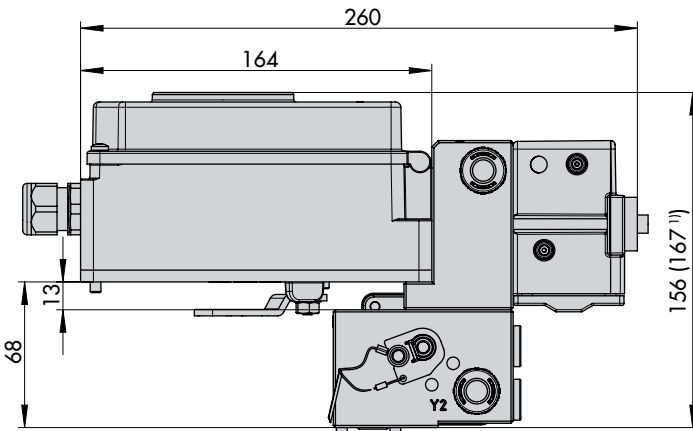

1) For attachment using intermediate plate

Attachment to rotary actuators according to VDI/VDE 3845
(attachment to double-acting actuator shown)

Heavy-duty version

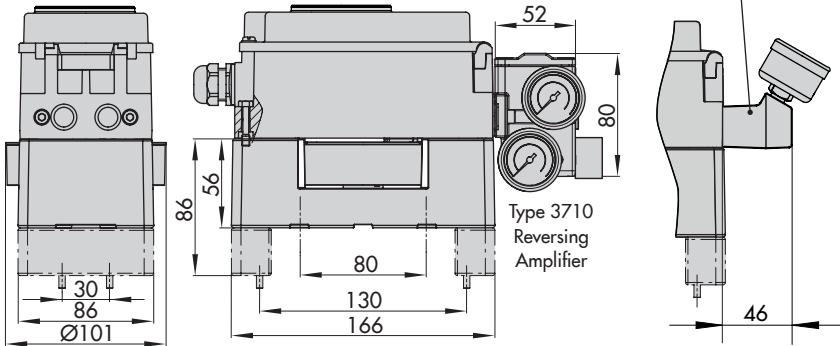

Light version

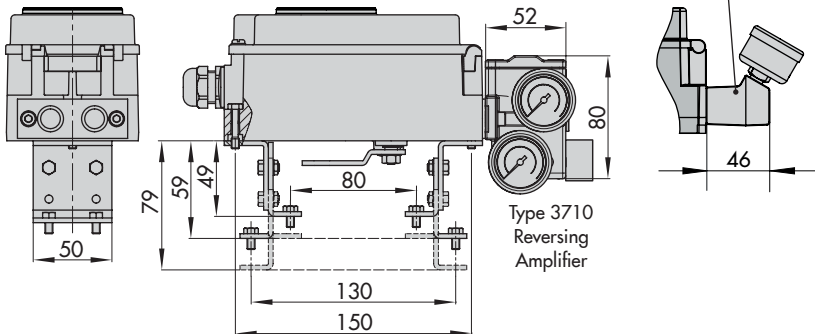

Lever

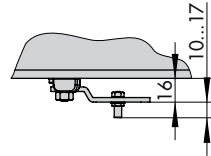
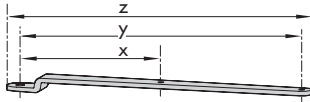

Lever	x	y	z
M	25 mm	50 mm	66 mm
L	70 mm	100 mm	116 mm
XL	100 mm	200 mm	216 mm
XXL	200 mm	300 mm	316 mm

3.6 Fixing levels according to VDI/VDE 3845 (September 2010)

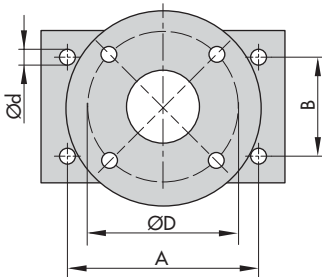
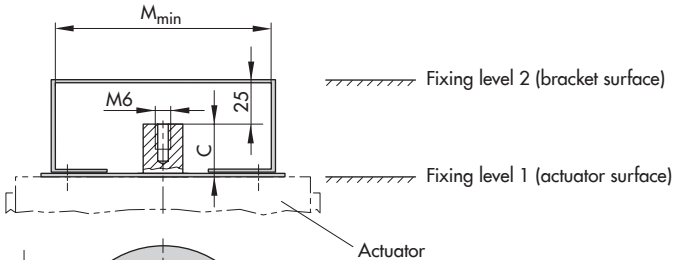

Dimensions in mm						
Size	A	B	C	Ød	M _{min}	D ¹⁾
AA0	50	25	15	5.5 for M5	66	50
AA1	80	30	20	5.5 for M5	96	50
AA2	80	30	30	5.5 for M5	96	50
AA3	130	30	30	5.5 for M5	146	50
AA4	130	30	50	5.5 for M5	146	50
AA5	200	50	80	6.5 for M6	220	50

¹⁾ Flange type F05 acc. to DIN EN ISO 5211

4 Shipment and on-site transport

The work described in this chapter is to be performed only by personnel appropriately qualified to carry out such tasks.

4.1 Accepting the delivered goods

After receiving the shipment, proceed as follows:

1. Check the scope of delivery. Check that the specifications on the nameplate of the positioner match the specifications in the delivery note. See the 'Markings on the device' chapter for nameplate details.
2. Check the shipment for transportation damage. Report any damage to SAMSON and the forwarding agent (refer to delivery note).

4.2 Removing the packaging from the positioner

Observe the following sequence:

- ➔ Do not remove the packaging until immediately before installing the positioner.
- ➔ Dispose and recycle the packaging in accordance with the local regulations.

4.3 Transporting the positioner

- ➔ Pack the positioner properly to comply with terms of transportation.

Transport instructions

- Protect the positioner against external influences (e.g. impact).
- Protect the positioner against moisture and dirt.
- Observe transport temperature depending on the permissible ambient temperature (see the 'Design and principle of operation' chapter).

4.4 Storing the positioner

! NOTICE

Risk of positioner damage due to improper storage.

- ➔ *Observe the storage instructions.*
- ➔ *Avoid longer storage periods.*
- ➔ *Contact SAMSON in case of different storage conditions or longer storage times.*

Storage instructions

- Protect the positioner against external influences (e.g. impact, shocks, vibration).
- Do not damage the corrosion protection (coating).
- Protect the positioner against moisture and dirt. In damp spaces, prevent con-

Shipment and on-site transport

densation. If necessary, use a drying agent or heating.

- Observe storage temperature depending on the permissible ambient temperature (see the 'Design and principle of operation' chapter).
- Store the positioner with the cover closed.
- Seal the pneumatic and electrical connections.

5 Installation

The work described in this chapter is to be performed only by personnel appropriately qualified to carry out such tasks.

⚠ DANGER

Risk of fatal injury due to the ignition of an explosive atmosphere.

- Observe EN 60079-14 (VDE 0165, Part 1) for work on the positioner in potentially explosive atmospheres.
- Work in potentially explosive atmospheres is to be performed only by personnel who has undergone special training or instructions or who is authorized to work on explosion-protected devices in hazardous areas.

⚠ WARNING

Crush hazard arising from moving parts on the valve.

- Do not touch any moving valve parts while the control valve is in operation.
- Before performing any mounting or installation work on the positioner, put the control valve out of operation by disconnecting and locking the supply air and control signal.
- Do not impede the movement of the actuator and plug stem by inserting objects into the yoke.

ⓘ NOTICE

Risk of malfunction due to incorrect mounting parts/accessories.

- Only use the mounting parts and accessories listed in these mounting and operating instructions to mount and install the positioner. Pay special attention to the type of attachment.

5.1 Installation conditions

Work position

The work position for the positioner is the front view onto the operating controls on the positioner seen from the position of operating personnel.

Operators must ensure that, after installation of the positioner, the operating personnel can perform all necessary work safely and easily access the device from the work position.

Mounting orientation

- Do not seal or restrict the vent opening (see Fig. 5-1) when the device is installed on site.
- Observe mounting position (see Fig. 5-2).

5.2 Preparation for installation

Before mounting, make sure the following conditions are met:

- The positioner is not damaged.
- The air supply is not yet connected to the positioner.
- The current is not yet connected to the positioner.

Proceed as follows:

- ➔ Lay out the necessary material and tools to have them ready during mounting.
- ➔ Adjust correct lever and pin position (see Chapter 5.4).
- ➔ Remove the protective caps from the pneumatic connections.

5.3 Turning the positioner shaft

Version without inductive limit switches

Use the Phillips screw head on the cap to lock the positioner shaft in place (see Fig. 5-5 left).

Version with inductive limit switches

To turn or hold the positioner shaft in position, turn or hold the actual shaft lock by hand.

- ➔ Do not use the locking screw to turn the positioner shaft knob. Only turn the rotary knob by hand (see Fig. 5-5, right).

5.4 Adjusting the lever and pin position

i Note

The M lever is included in the scope of delivery.

S, L, XL levers are available as accessories (see Table 5-7). The XXL lever is available on request.

The positioner is adapted to the actuator and to the rated travel by the lever on the back of the positioner and the pin inserted into the lever.

The travel tables on page 5-4 show the maximum adjustment range at the positioner. The travel that can be implemented at the valve is additionally restricted by the selected fail-safe position and the required compression of the actuator springs.

The positioner is equipped with the M lever (pin position 35) as standard (see Fig. 5-3).

If a pin position other than position 35 with the standard M lever is required or an L or XL lever size is required, proceed as follows (see Fig. 5-4):

1. Fasten the follower pin (2) in the assigned lever hole (pin position as specified in the travel tables on page 5-4). Only use the longer follower pin included in the mounting kit.
2. Place the lever (1) on the shaft of the positioner and fasten it tight using the disk spring (1.2) and nut (1.1).

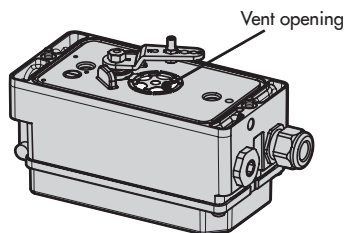

Fig. 5-1: Vent opening
(back of the positioner)

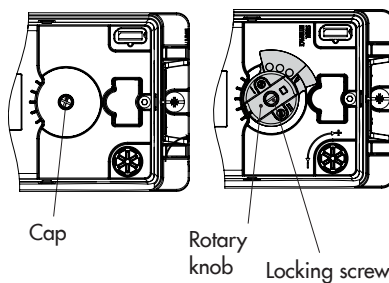

Fig. 5-5: Shaft locking
(left) without inductive limit switches
(right) with inductive limit switches

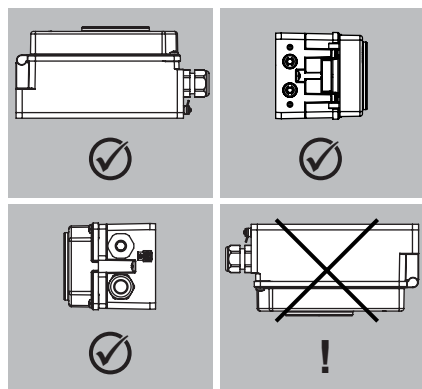

Fig. 5-2: Permissible mounting
positions

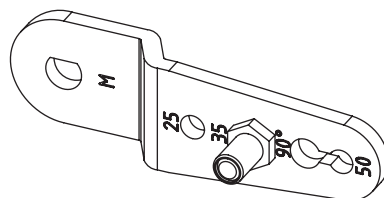
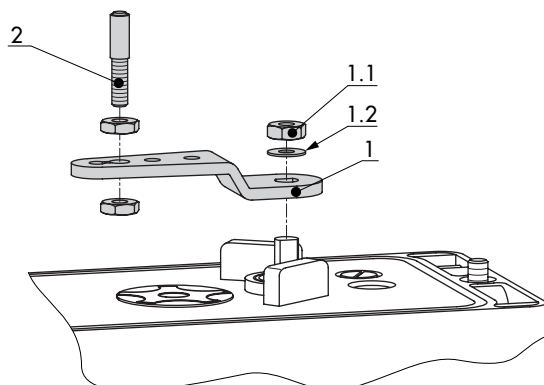

Fig. 5-3: M lever with pin position 35



- 1 Lever
- 1.1 Nut
- 1.2 Disk spring
- 2 Follower pin

Fig. 5-4: Mounting the lever
and follower pin

5.4.1 Travel tables

i Note

The **M** lever is included in the scope of delivery.

S, L, XL levers for attachment according to IEC 60534-6 (NAMUR) are available as accessories (see Table 5-7 on page 5-47). The **XXL** lever is available on request.

Table 5-1: Direct attachment to Type 3277-5 and Type 3277 Actuator

Actuator size [cm ²]	Rated travel [mm]	Adjustment range at positioner Travel [mm]	Required lever	Assigned pin position
120	7.5	5.0 to 25.0	M	25
120/175/ 240/350	15	7.0 to 35.0	M	35
355/700/750	30	10.0 to 50.0	M	50

Table 5-2: Attachment according to IEC 60534-6 (NAMUR)

SAMSON valves with Type 3271 Actuator		Adjustment range at positioner Other control valves		Required lever	Assigned pin position
Actuator size [cm ²]	Rated travel [mm]	Min. travel [mm]	Max. travel [mm]		
120 with Type 3510 Valve	7.5	3.5	17.5	S	17
120	7.5	5.0	25.0	M	25
120/175/240/350	15	7.0	35.0	M	35
700/750	7.5	7.0	35.0	M	35
355/700/750	15 and 30	10.0	50.0	M	50
1000/1400/2800	30	14.0	70.0	L	70
	60	20.0	100.0	L	100
1400/2800	120	40.0	200.0	XL	200
1400	250	60.0	300.0	XXL	300

Table 5-3: Attachment to rotary actuators

Opening angle	Required lever	Assigned pin position
24 to 100°	M	90°

5.5 Installing a volume restriction

We recommend using a volume restriction to adapt the air output capacity to the size of the actuator:

- For linear actuators with a transit time < 1 s (e.g. with an actuator area smaller than 240 cm^2),
- For rotary actuators with a volume of less than 300 cm^3 .

Volume restriction in the connection block (direct attachment). See Fig. 5-6.

➔ Order no. 100041955

1. Apply a thin film of lubricant to the O-ring at the signal pressure output.
2. Carefully push and turn the volume restriction (1) (e.g. using a hex wrench) into the opening (tube) of the signal pressure output at the connection block as far as it will go.
3. Place the connection block (2) against the positioner and the actuator yoke and fasten using the screw.

Volume restriction on the connecting plate/pressure gauge bracket (see Fig. 5-7)

➔ Order no. 100041162

1. Insert the volume restriction (1) with O-ring at the signal pressure output of the connecting plate (3)/pressure gauge bracket in place of the existing O-ring.
2. Place the connecting plate (3)/pressure gauge bracket (4) on the positioner and fasten using screws and spring washers.

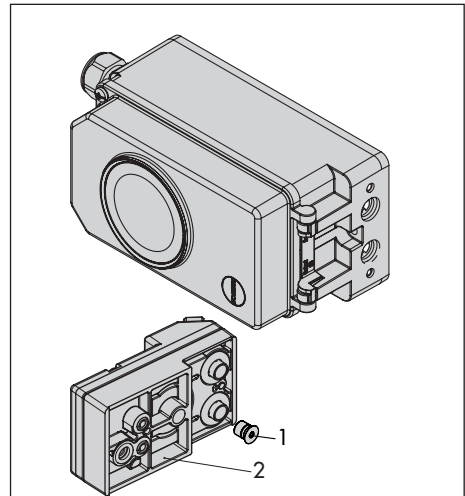

Fig. 5-6: Installing the volume restriction (1) in the connection block (2)

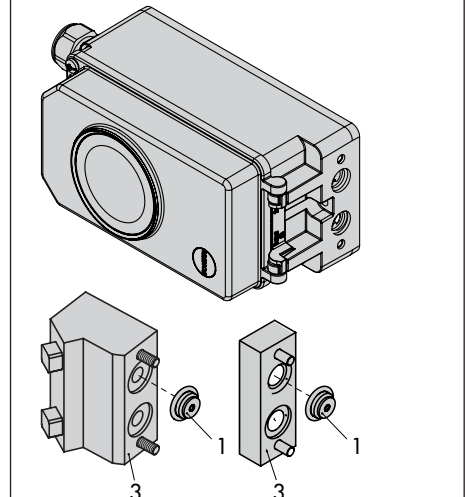

Fig. 5-7: Installing the volume restriction (1) on the connecting plate (3) or pressure gauge bracket (4)

5.6 Positioner attachment

i Note

We recommend using a volume restriction for a transit time <1 s (see Chapter 5.5).

5.6.1 Direct attachment

a) Type 3277-5 Actuator

- Direct attachment to actuator (120 cm²)
 - Positioner without pressure sensors: (see Fig. 5-8)
 - Required mounting parts and accessories: Table 5-5 on page 5-45.
 - Observe travel tables on page 5-4.
 - Depending on the fail-safe action of the actuator "actuator stem extends" or "actuator stem retracts", mount the switchover plate (9) on the actuator yoke. Align the symbol for attachment to the left or right side with the marking (see Fig. 5-8, top).
1. Mount connecting plate (6) or pressure gauge bracket (7) with pressure gauges on the positioner. Make sure that the two seals (6.1) are seated properly.
 2. Remove screw plug (4) on the back of the positioner and seal the signal pressure output (38) on the connecting plate (6) or on the pressure gauge bracket (7) with the stopper (5) included in the accessories.
 3. Place follower clamp (3) on the actuator stem, align it and screw tight so that the mounting screw is located in the groove of the actuator stem.
 4. Mount cover plate (10) with narrow side of the cut-out (Fig. 5-8, on the left) pointing towards the signal pressure connection. Make sure that the gasket (14) points towards the actuator yoke.
 5. Check the pin position of the follower pin (2) on M lever (1). Refer to travel tables for type of attachment. If necessary, change the pin position (see Chapter 5.4).
 6. Insert molded seal (15) into the groove of the positioner housing and insert the seal (10.1) on the back of the housing.
 7. Place positioner on the cover plate (10) in such a manner that the follower pin (2) rests on the top of the follower clamp (3). Adjust the lever (1) correspondingly and open the positioner cover to hold the positioner shaft in position at the shaft lock (Fig. 5-5). The lever (1) must rest on the follower clamp with spring force. Fasten the positioner on the cover plate (10) using the two fastening screws.
 8. Mount cover (11) on the other side. Make sure that the vent plug is located at the bottom when the control valve is installed to allow any condensed water that collects to drain off.

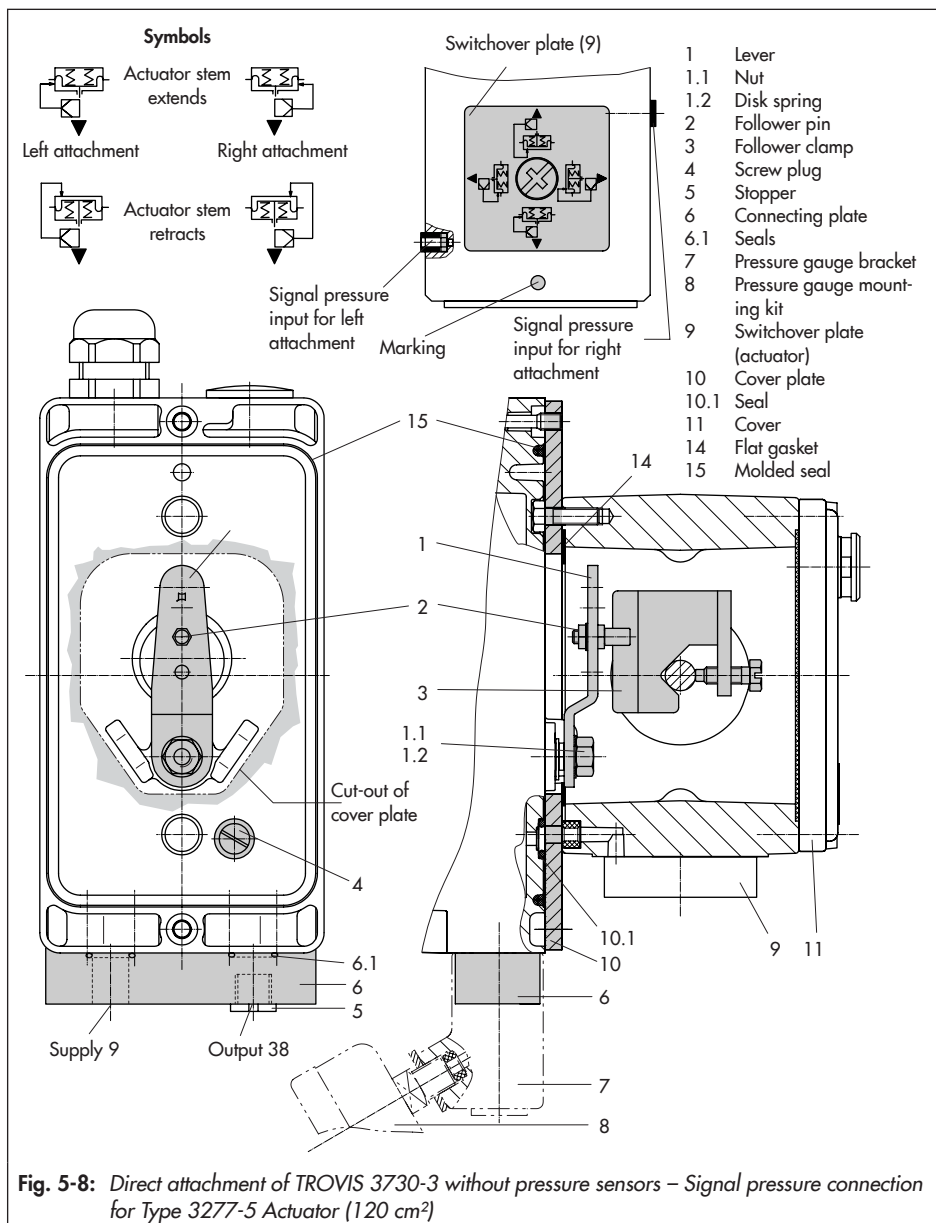

b) Type 3277 Actuator

- ➔ Actuators with 175 to 750 cm² (Fig. 5-9)
- ➔ Required mounting parts and accessories: Table 5-6 on page 5-46.
- ➔ Observe travel tables on page 5-4.

1. Seal the signal pressure output at the back of the positioner with the screw plug (4, order no. 0180-1254) and the associated O-ring (order no. 0520-0412) if the screw plug is not yet in place.
2. Place follower clamp (3) on the actuator stem, align it and screw tight so that the mounting screw is located in the groove of the actuator stem.
3. Mount cover plate (10) with narrow side of the cut-out (Fig. 5-9, on the left) pointing towards the signal pressure connection. Make sure that the gasket (14) points towards the actuator yoke.
4. Check the pin position of the follower pin (2) on M lever (1). Refer to travel tables for type of attachment. If necessary, change the pin position (see Chapter 5.4).
5. Insert molded seal (15) into the groove of the positioner housing.
6. Place positioner on the cover plate in such a manner that the follower pin (2) rests on the top of the follower clamp (3). Adjust the lever (1) correspondingly and open the positioner cover to hold the positioner shaft in position at the shaft lock (Fig. 5-5). The lever (1) must rest on the follower clamp with spring force.

Fasten the positioner on the cover plate (10) using the two fastening screws.

7. Make sure that the tip of the gasket (16) projecting from the side of the connection block is positioned to match the actuator symbol for the actuator's fail-safe action "actuator stem extends" or "actuator stem retracts". If this is not the case, unscrew the three fastening screws and lift off the cover. Turn the gasket (16) by 180° and re-insert it.
8. Place the connection block (12) with the associated seals against the positioner and the actuator yoke and fasten using the screw (12.1). For actuators with fail-safe action "actuator stem retracts", additionally remove the stopper (12.2) and mount the external signal pressure pipe.
9. Mount cover (11) on the other side. Make sure that the vent plug is located at the bottom when the control valve is installed to allow any condensed water that collects to drain off.

5.6.2 Attachment according to IEC 60534-6

- ➔ Required mounting parts and accessories: Table 5-7 on page 5-47.
- ➔ Observe travel tables on page 5-4.
- ➔ See Fig. 5-10

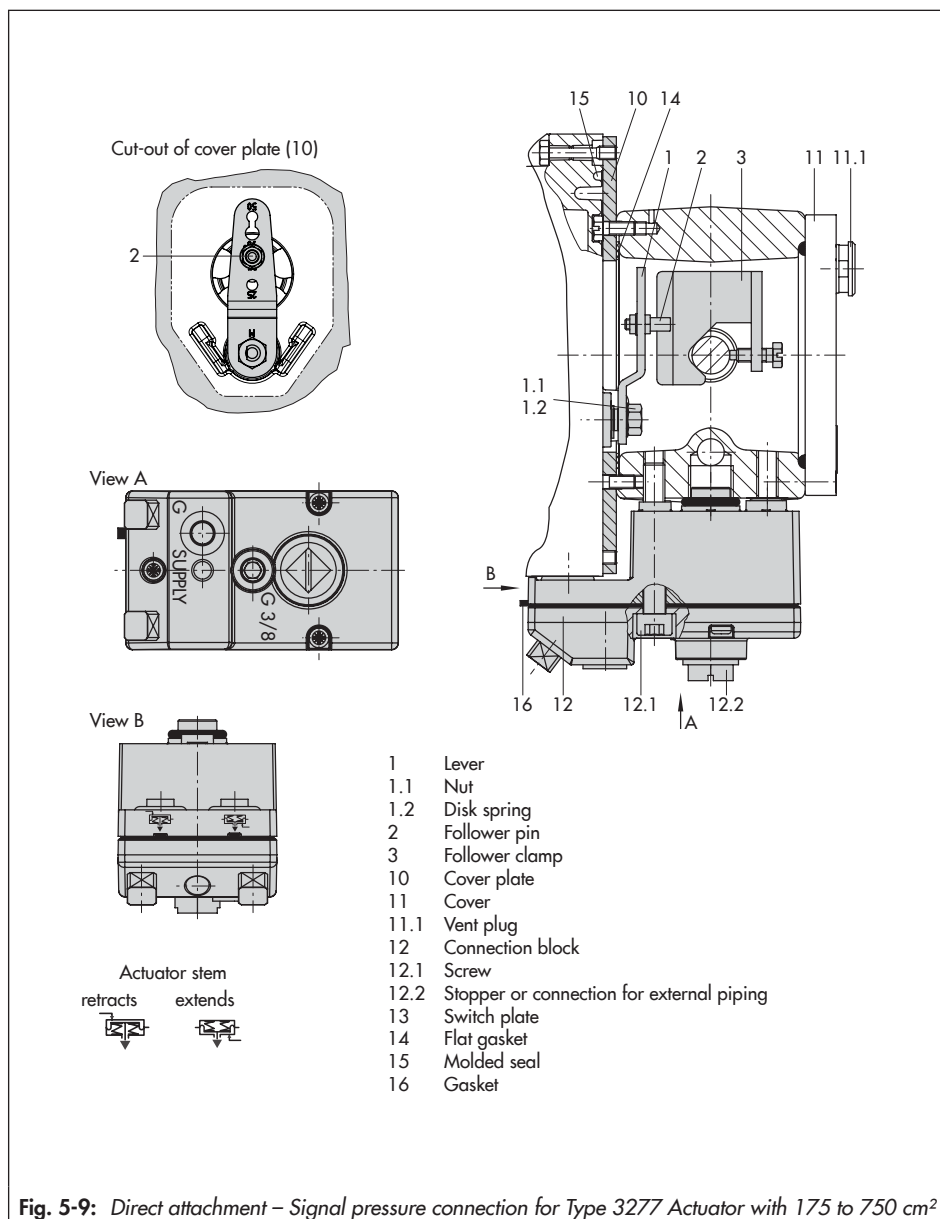

Installation

The positioner is attached to the control valve using a NAMUR bracket (10).

1. Seal the signal pressure output at the back of the positioner with the screw plug (4, order no. 0180-1254) and the associated O-ring (order no. 0520-0412) if the screw plug is not yet in place.
2. Screw the two bolts (14) to the bracket (9.1) of the stem connector (9), place the follower plate (3) on top and use the screws (14.1) for fastening.

Actuator sizes 2800 cm² and 1400 cm² with 120 mm travel:

- For a travel of 60 mm or smaller, screw the longer follower plate (3.1) directly to the stem connector (9).
 - For a travel exceeding 60 mm, mount the bracket (16) first and then the follower plate (3) to the bracket together with the bolts (14) and screws (14.1).
3. Mount NAMUR bracket (10) to the control valve as follows:
 - For **attachment to the NAMUR rib**, use an M8 screw (11) and toothed lock washer directly in the yoke hole.
 - For attachment to **valves with rod-type yokes**, use two U-bolts (15) around the yoke. Align the NAMUR bracket (10) according to the embossed scale so that the follower plate (3) is shifted by half the angle range to the NAMUR bracket (the slot of the follower plate is centrally aligned with the NAMUR bracket at mid valve travel).

4. Mount connecting plate (6) or pressure gauge bracket (7) with pressure gauges (8) on the positioner. Make sure that the two seals (6.1) are seated properly.
5. Select required lever size (1) M, L or XL and pin position according to the actuator size and valve travel listed in the travel table on page 5-4.

Should a pin position other than position **35** with the standard **M** lever be required or an **L** or **XL** lever size be required, proceed as follows:

6. Fasten the follower pin (2) in the assigned lever hole (pin position as specified in the travel table). Only use the longer follower pin (2) included in the mounting kit.
7. Place the lever (1) on the shaft of the positioner and fasten it tight using the disk spring (1.2) and nut (1.1). Move lever once all the way as far as it will go in both directions.
8. Place positioner on the NAMUR bracket in such a manner that the follower pin (2) rests in the slot of the follower plate (3, 3.1). Adjust the lever (1) correspondingly.
Screw the positioner to the NAMUR bracket using its two fastening screws.

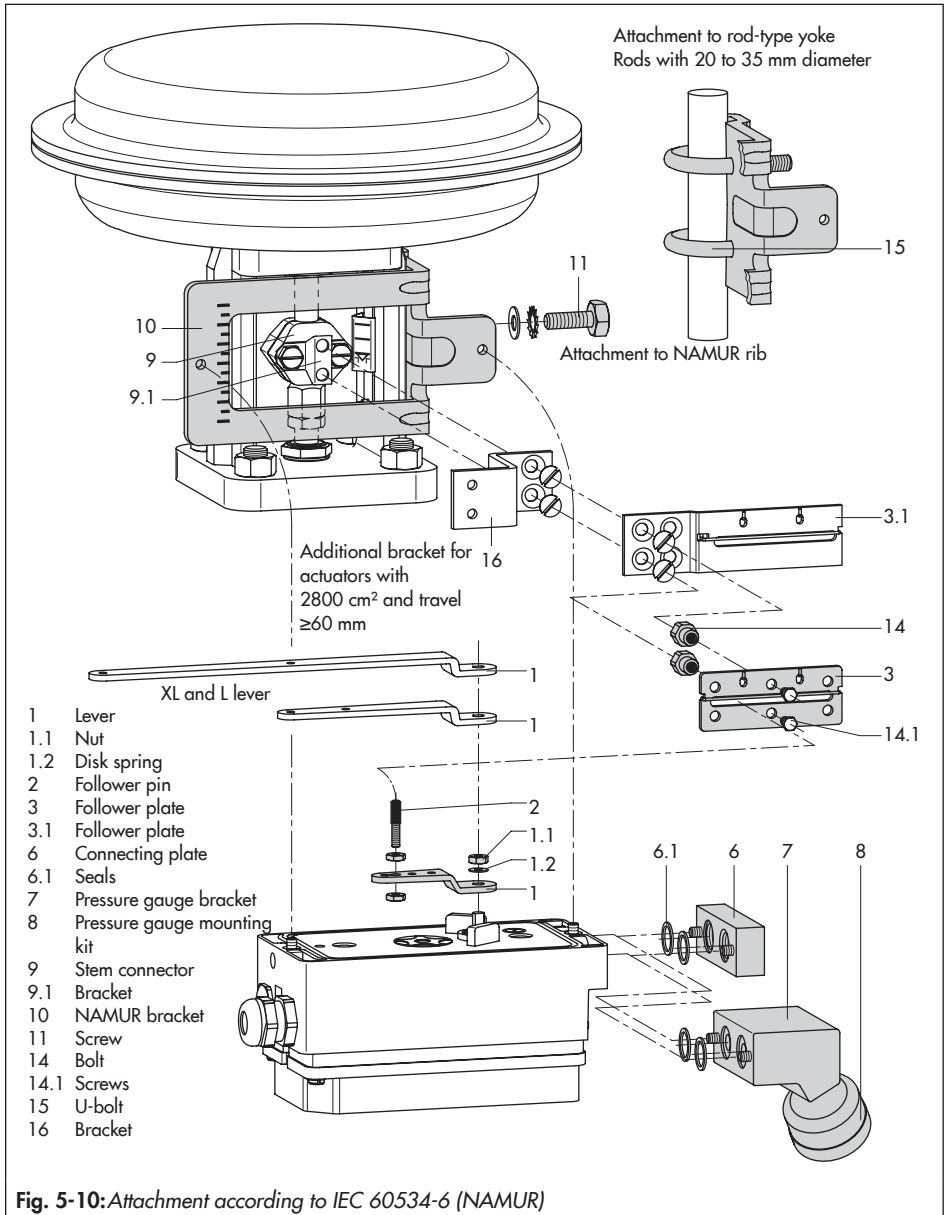

5.6.3 Attachment to Type 3510 Micro-flow Valve

→ See Fig. 5-11

→ Required mounting parts and accessories: Table 5-7 on page 5-47.

The volume restriction is required for micro-flow valves and when the output port at the side is used.

→ Observe travel tables on page 5-4.

The positioner is attached to the valve yoke using a bracket.

1. Seal the signal pressure output at the back of the positioner with the screw plug (4, order no. 0180-1254) and the associated O-ring (order no. 0520-0412) if the screw plug is not yet in place.
2. Fasten the bracket (9.1) to the stem connector.
3. Screw the two bolts (9.2) to the bracket (9.1) of the stem connector (9), place the follower plate (3) on top and use the screws (9.3) for fastening.
4. Mount the travel indication scale (accessories) to the outer side of the yoke using the hex screws (12.1), ensuring that the scale is aligned with the stem connector.
5. Fasten the hex bar (11) onto the outer side of yoke by screwing the M8 screws (11.1) directly into the holes on the yoke.
6. Fasten the bracket (10) to the hex bar (11) using the hex screw (10.1), shim and tooth lock washer.
7. Mount connecting plate (6) or pressure gauge bracket (7) with pressure gauges on the positioner. Make sure that the seal (6.1) and the volume restriction (6.2) are seated properly.
8. Unscrew the standard M lever (1) including follower pin (2) from the positioner shaft.
9. Take the S lever (1) and screw the follower pin (2) in the hole for pin position 17.
10. Place the S lever on the positioner shaft and screw tight using the disk spring (1.2) and nut (1.1). Move lever once all the way as far as it will go in both directions.
11. Place positioner on the bracket (10) in such a manner that the follower pin slides into the groove of the follower pin (3). Adjust the lever (1) correspondingly. Screw the positioner to the bracket (10) using both its screws.

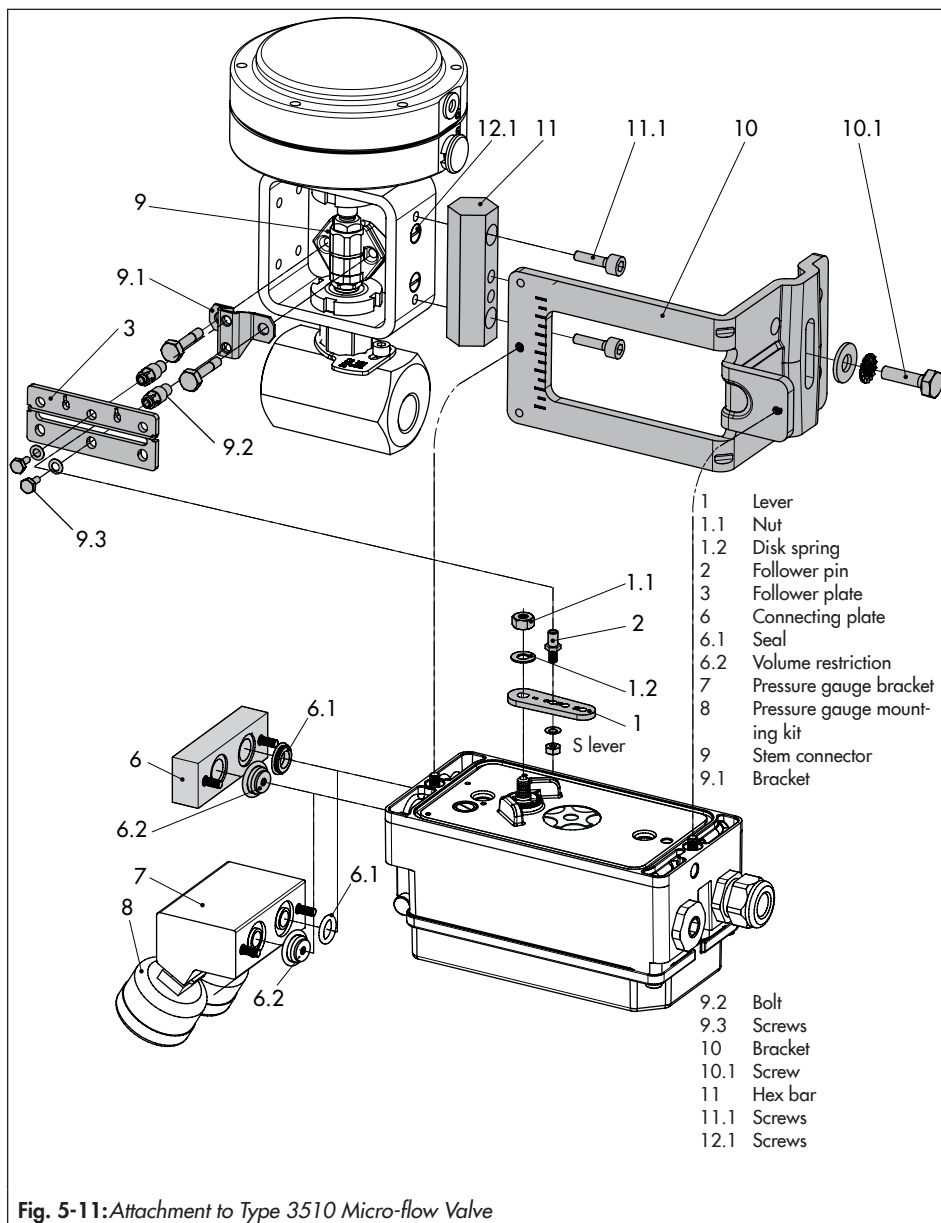

Fig. 5-11: Attachment to Type 3510 Micro-flow Valve

5.6.4 Attachment according to VDI/VDE 3847-1

→ See Fig. 5-12.

This type of attachment allows the positioner to be replaced quickly while the process is running by blocking the air in the actuator.

The signal pressure can be blocked in the actuator by unscrewing the red retaining screw (20) and turning the air blocker (19) on the bottom of the adapter block. This causes the actuator to be blocked to allow the positioner to be replaced, for example.

Attachment to Type 3277 Actuator (see Fig. 5-12)

→ Required mounting parts and accessories: Table 5-8 on page 5-48.

Mount the positioner on the yoke as shown in Fig. 5-12. The signal pressure is routed to the actuator over the connecting plate (12), for actuators with fail-safe action "actuator stem extends" internally through a bore in the valve yoke and for "actuator stem retracts" through external piping.

Only the Y1 port is required for positioner attachment. The Y2 port can be used for air purging of the spring chamber.

1. Seal the signal pressure output at the back of the positioner with the screw plug (4, order no. 0180-1254) and the associated O-ring (order no. 0520-0412) if the screw plug is not yet in place.
2. Place follower clamp (3) on the actuator stem, align it and screw tight so that the

mounting screw is located in the groove of the actuator stem.

3. Place the adapter bracket (6) on the positioner and mount using the screws (6.1). Make sure that the seals are correctly seated. For positioners **with air purging**, remove the stopper (5) before mounting the positioner. For positioners **without air purging**, replace the screw plug (4) with a vent plug.
4. For actuators with 355, 700 or 750 cm², remove the follower pin (2) on the M lever (1) on the back of the positioner from pin position 35, reposition it in the hole for pin position 50 and screw tight.
For actuators 175, 240 and 350 cm² with 15 mm travel, keep the follower pin (2) in pin position 35.
5. Insert the molded seal (6.2) in the groove of the adapter bracket (6).
6. Insert the molded seal (17.1) into the turnboard (17) and mount the turnboard to the adapter block (13) using the screws (17.2).
7. Mount the dummy plate (18) to the turnboard (17) using the screws (18.1). Make sure that the seals are correctly seated.

i Note

A solenoid valve can also be mounted in place of the dummy plate (18). The orientation of the turnboard (17) determines the mounting position of the solenoid valve. Alternatively, a restrictor plate can be mounted (► AB 11).

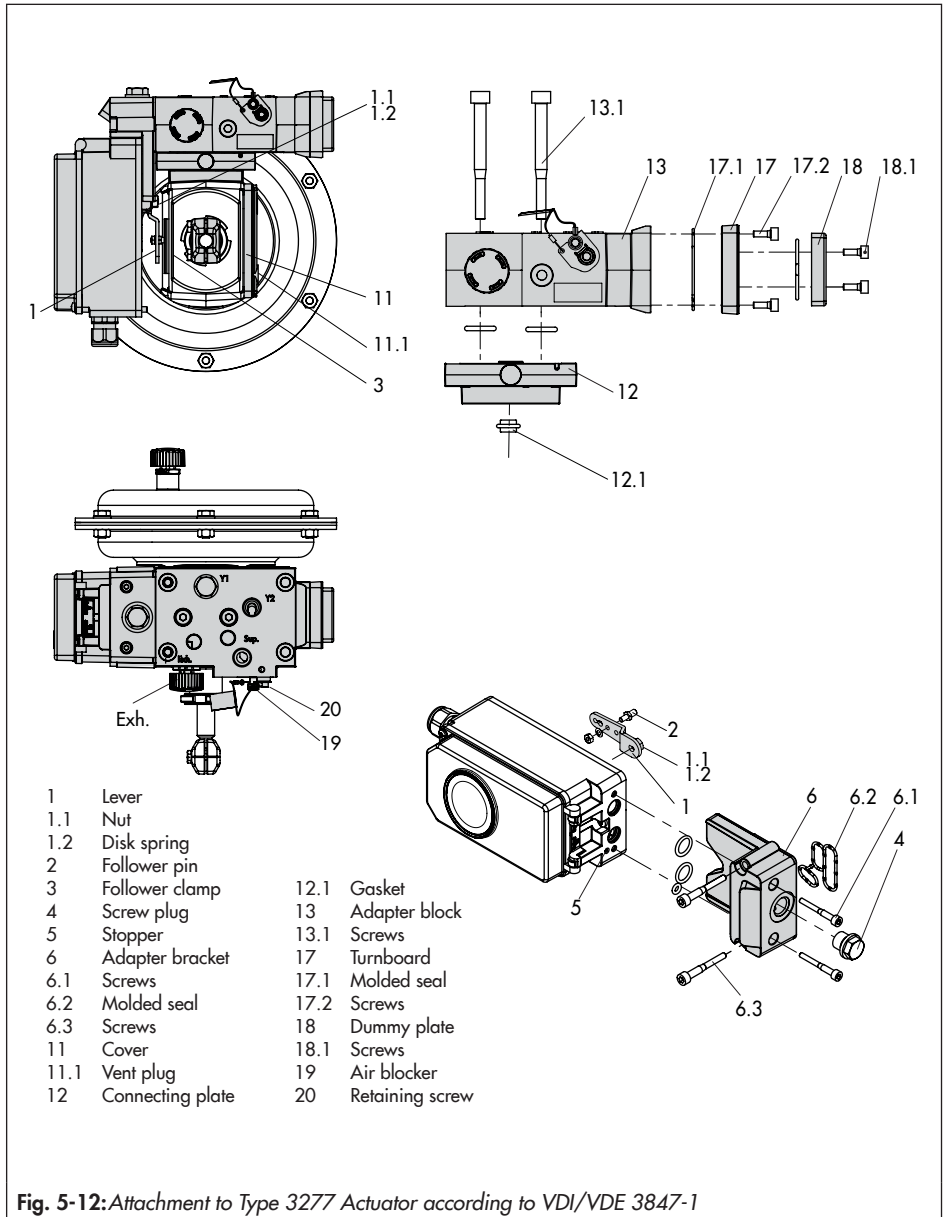
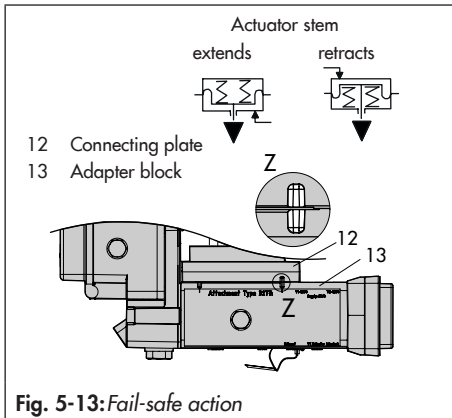

Fig. 5-12: Attachment to Type 3277 Actuator according to VDI/VDE 3847-1

Installation

8. Insert the screws (13.1) through the middle holes of the adapter block (13).
9. Place the connecting plate (12) together with the seal (12.1) onto the screws (13.1) corresponding to the fail-safe action "actuator stem extends" or "actuator stem retracts". The fail-safe action that applies is determined by aligning the groove of the adapter block (13) with the groove of the connecting plate (12) (Fig. 5-13).



10. Mount the adapter block (13) together with the connecting plate (12) to the actuator using the screws (13.1).
11. Insert the vent plug (11.1) into the **Exh.** connection.
12. For fail-safe action "actuator stem extends", seal the Y1 port with a blanking plug.
For fail-safe action "actuator stem retracts", connect the Y1 port to the signal pressure connection of the actuator.

13. Place positioner on the adapter block (13) in such a manner that the follower pin (2) rests on the top of the follower clamp (3). Adjust the lever (1) correspondingly and open the positioner cover to hold the positioner shaft in position at the shaft lock (Fig. 5-5). The lever (1) must rest on the follower clamp with spring force.
14. Fasten the positioner to the adapter block (13) using the two fastening screws (6.3). Make sure the molded seal (6.2) is properly seated.
15. Mount cover (11) on the other side to the yoke. Make sure that the vent plug is located at the bottom when the control valve is installed to allow any condensed water that collects to drain off.

Attachment according to IEC 60534-6 (NAMUR) and VDI/VDE 3847-1 (see Fig. 5-14)

- Required mounting parts and accessories: Table 5-8 on page 5-48.
 - Observe travel tables on page 5-4.
1. **Series 240 Valves, actuator size up to 1400-60 cm²:** Screw the two bolts (14) to the bracket of the stem connector or directly to the stem connector (depending on the version), place the follower plate (3) on top and use the screws (14.1) to fasten it.
Type 3251 Valve, 350 to 2800 cm²: Screw the longer follower plate (3.1) to the bracket of the stem connector or directly to the stem connector (depending on the version).

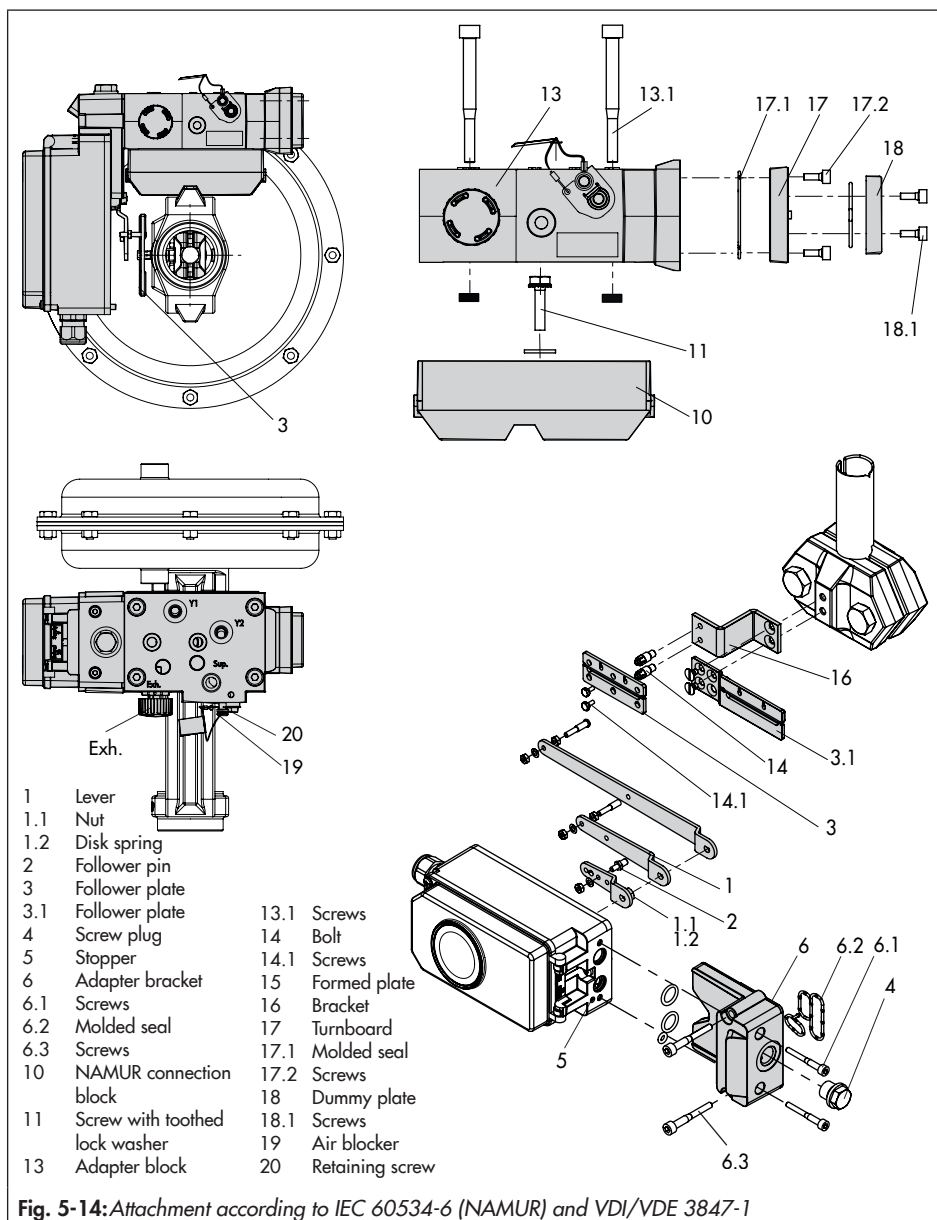

Type 3254 Valve, 1400-120 to 2800

cm²: Screw the two bolts (14) to the bracket (16). Fasten the bracket (16) onto the stem connector, place the follower plate (3) on top and use the screws (14.1) to fasten it.

Mount the positioner on the NAMUR rib as shown in Fig. 5-14.

- For **attachment to the NAMUR rib**, fasten the NAMUR connection block (10) directly into the existing yoke bore using the screw and toothed lock washer (11). Align the marking on the NAMUR valve connection (on the side marked '1') to 50 % travel.

For attachment to **valves with rod-type yokes** using the formed plate (15), which is placed around the yoke: screw the four studs into the NAMUR connection block (10). Place the NAMUR connection block on the rod and position the formed plate (15) on the opposite side. Use the nuts and toothed lock washers to fasten the formed plate onto the studs. Align the marking on the NAMUR valve connection (on the side marked '1') to 50 % travel.

- Place the adapter bracket (6) on the positioner and mount using the screws (6.1). Make sure that the seals are correctly seated. For positioners **with air purging**, remove the stopper (5) before mounting the positioner. For positioners **without air purging**, replace the screw plug (4) with a vent plug.
- Select required lever size (1) M, L or XL and pin position according to the actual

size and valve travel listed in the travel table on page 5-4.

Should a pin position other than position 35 with the standard M lever be required or an L or XL lever size be required, proceed as follows:

- Fasten the follower pin (2) in the assigned lever hole (pin position as specified in the travel table). Only use the longer follower pin (2) included in the mounting kit.
 - Place the lever (1) on the shaft of the positioner and fasten it tight using the disk spring (1.2) and nut (1.1).
 - Move lever once all the way as far as it will go in both directions.
- Insert the molded seal (6.2) in the groove of the adapter bracket.
 - Insert the molded seal (17.1) into the turnboard (17) and mount the turnboard to the adapter block (13) using the screws (17.2).
 - Mount the dummy plate (18) to the turnboard using the screws (18.1). Make sure that the seals are correctly seated.

i Note

A solenoid valve can also be mounted in place of the dummy plate (18). The orientation of the turnboard (17) determines the mounting position of the solenoid valve. Alternatively, a restrictor plate can be mounted (► AB 11).

- Fasten the adapter block (13) to the NAMUR connection block using the screws (13.1).

9. Insert the vent plug into the Exh. connection.
10. Place the positioner on the adapter block (13) in such a manner that the follower pin (2) rests on the top of the follower plate (3, 3.1). Adjust the lever (1) correspondingly.

Fasten the positioner to the adapter block (13) using the two fastening screws (6.3). Make sure the molded seal (6.2) is properly seated.

11. For **single-acting actuators without air purging**, connect the Y1 port of the adapter block to the signal pressure connection of the actuator. Seal the Y2 port with a blanking plug.

For **double-acting actuators and actuators with air purging**, connect the Y2 port of the adapter block to the signal pressure connection of the second actuator chamber or spring chamber of the actuator.

5.6.5 Attachment according to VDI/VDE 3847-2

Attachment according to VDI/VDE 3847-2 for SRP (single-acting) and DAP (double-acting) rotary actuators in sizes 60 to 1200 with NAMUR interface and air purging of the actuator's spring chamber allows the direct attachment of the positioner without additional piping.

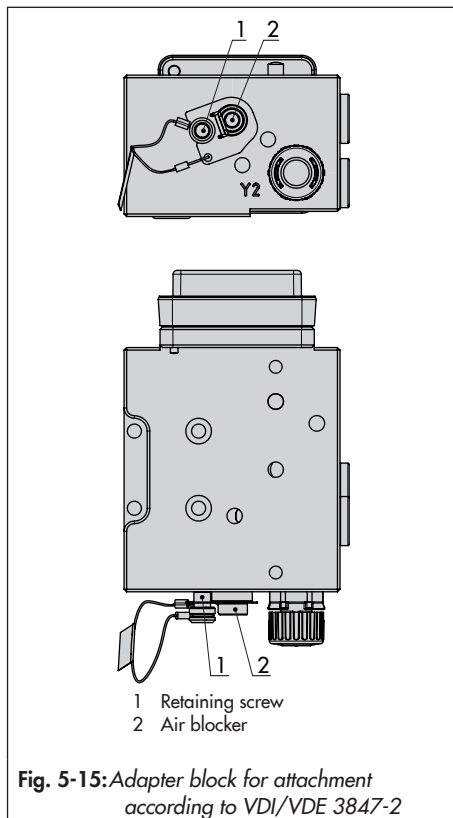

Fig. 5-15: Adapter block for attachment according to VDI/VDE 3847-2

Additionally, the positioner can be replaced quickly while the process is running by blocking the air in single-acting actuators.

Blocking the actuator in place (see Fig. 5-15):

1. Unscrew the red retaining screw (1).
2. Turn the air blocker (2) on the bottom of the adapter block according to the inscription.

a) Version for single-acting actuator

Mounting on Type 31a Actuator (edition 2020+), SRP version

→ See Fig. 5-17

1. Seal the signal pressure output at the back of the positioner with the screw plug (4, order no. 0180-1254) and the associated O-ring (order no. 0520-0412) if the screw plug is not yet in place.
2. Fasten the adapter block (1) to the actuator's NAMUR interface using the four fastening screws (2).
→ Make sure that the seals are correctly seated.
3. Mount the follower wheel (3) onto the actuator shaft. Use the matching shaft adapter (see Table 5-9 on page 5-48).
4. Place the adapter bracket (4) onto the adapter block (1) and fasten it using the fastening screws (5).
→ Make sure that the seals are correctly seated.
5. Insert and fasten the follower pin in the 90° position on the positioner's lever (see Fig. 5-16). Only use the longer follower pin included in the mounting kit.
6. Align the positioner on the adapter bracket (1) in such a way that the follower pin engages into the actuator's follower wheel (3).

7. Fasten the positioner onto the adapter bracket (4) using the fastening screws (6).
→ Make sure that the seals are correctly seated.

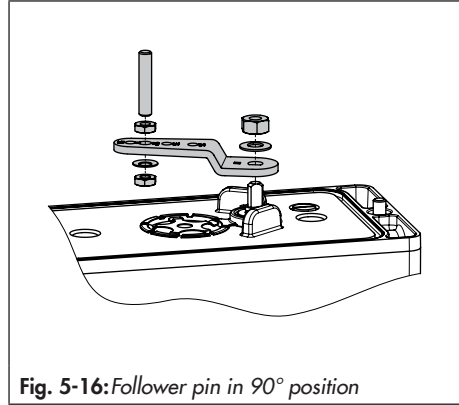
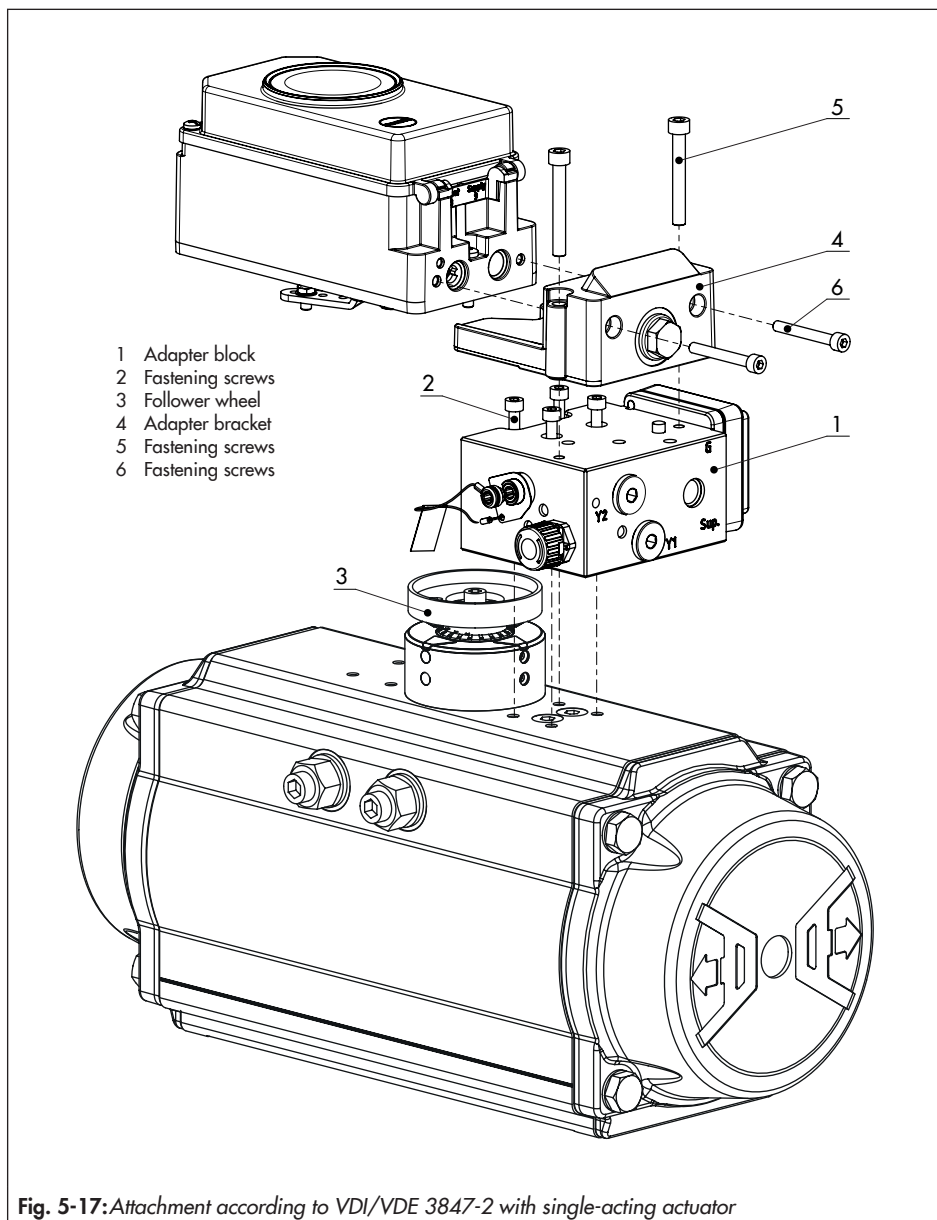

Fig. 5-16: Follower pin in 90° position



b) Version for double-acting or single-acting actuator with partial stroke testing (PST)

A reversing amplifier must be additionally mounted for applications with double-acting (DAP) actuators or applications with single-acting (SAP) actuators that include partial stroke testing.

In this case, a special adapter bracket (4) is required for mounting.

→ See Fig. 5-19.

1. Seal the signal pressure output at the back of the positioner with the screw plug (4, order no. 0180-1254) and the associated O-ring (order no. 0520-0412) if the screw plug is not yet in place.
2. Fasten the adapter block (1) to the actuator's NAMUR interface using the four fastening screws (2). Make sure the seals are correctly seated.
3. Mount the follower wheel (3) onto the actuator shaft. Use the matching adapter (see Table 5-9 on page 5-48).
4. Place the adapter bracket (4) onto the adapter block (1) and fasten it using the fastening screws (5). Make sure the seals are correctly seated.
5. Insert and fasten the follower pin into the 90° position on the positioner's lever (see Fig. 5-16 on page 5-20).
6. Align the positioner on the adapter bracket (1) in such a way that the follower pin engages into the actuator's follower wheel (3).
7. Fasten the positioner onto the adapter bracket (4) using the fastening screws (6).
8. Mount the Type 3710 Reversing Amplifier (7) together with the two guide bushings (8) and terminal plate (9) onto the adapter bracket using the associated fastening screws (10). Make sure the seals are correctly seated.
9. Remove the vent plug at the adapter block and seal the opening with the G ¼ screw plug.
10. Mount the turnboard marked '**Doppel**' for double-acting actuators or the turnboard marked '**PST**' for single-acting actuators with partial stroke testing. See Fig. 5-18. Make sure the seals are correctly seated.

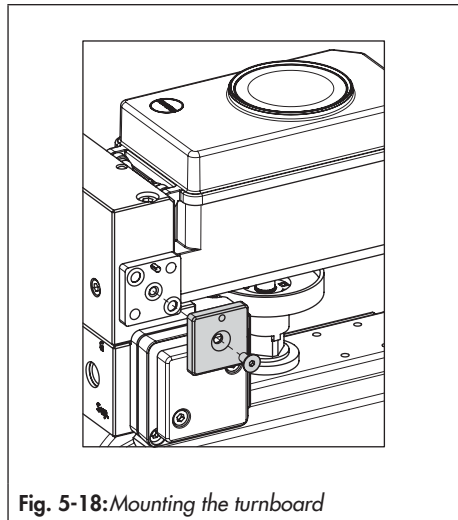
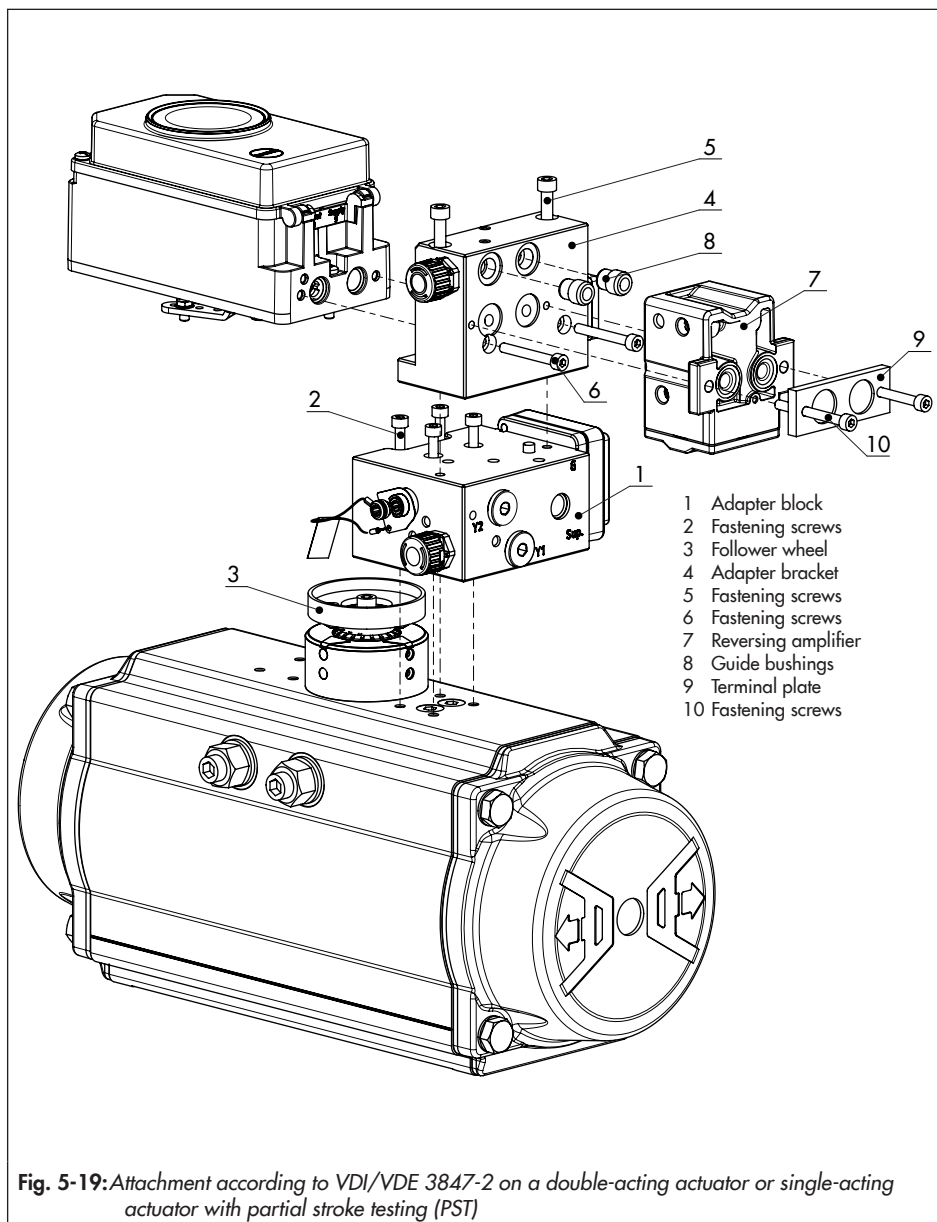

Fig. 5-18: Mounting the turnboard



Intermediate plate for AA4 interface

→ See Fig. 5-20.

An intermediate plate (1) must be mounted between the adapter block and adapter bracket for SRP and DAP rotary actuators in sizes 900 and 1200 with AA4 interface. This plate is included in the accessories for the shaft adapter AA4 (see Table 5-9 on page 5-48).

Mounting a solenoid valve

→ See Fig. 5-21.

A solenoid valve (13) can also be mounted in place of the dummy plate (12). The orientation of the turnboard (14) determines the mounting position of the solenoid valve. Alternatively, a restrictor plate can be mounted. Further information can be found in the document ► AB 11 (Accessories for Solenoid Valves).

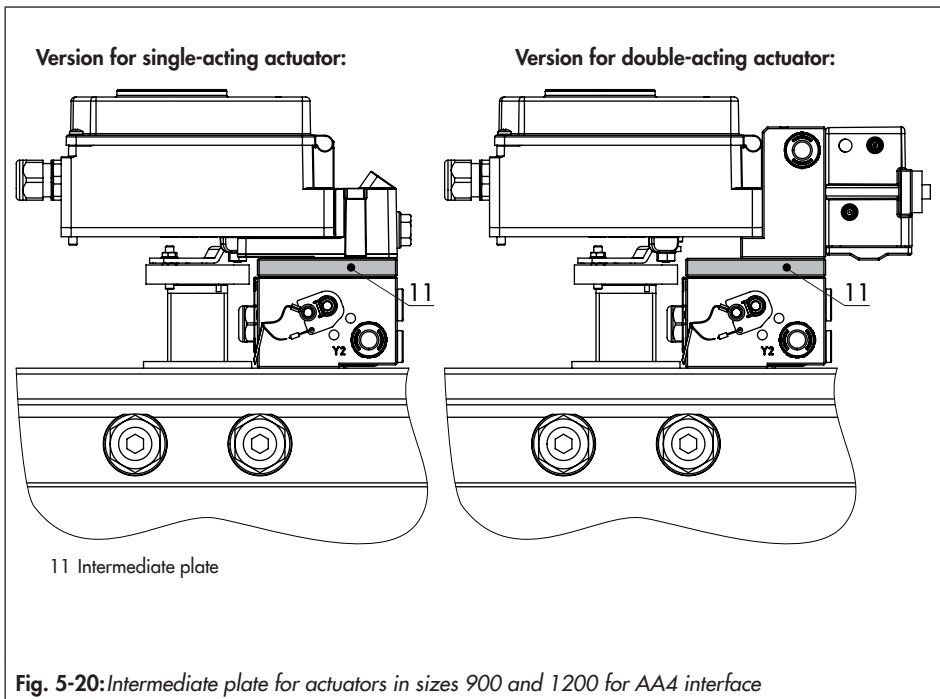

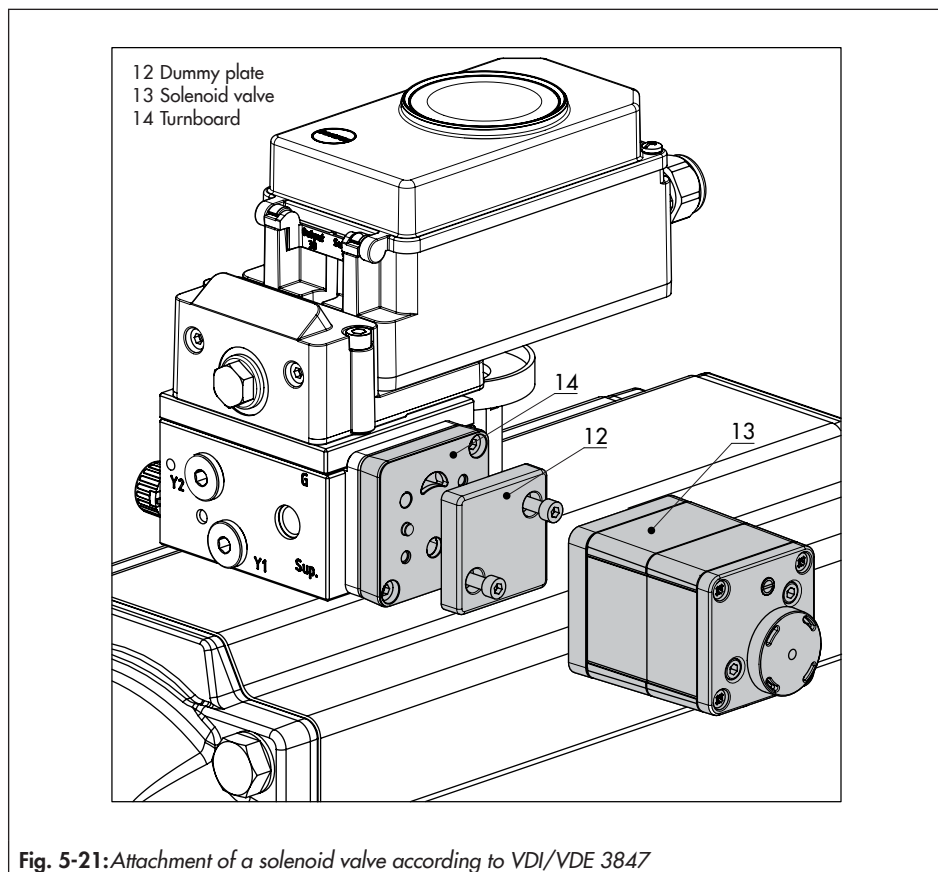

Fig. 5-21: Attachment of a solenoid valve according to VDI/VDE 3847

5.6.6 Attachment according to VDI/VDE 3845

a) Standard version

- ➔ See Fig. 5-23
- ➔ Required mounting parts and accessories: Table 5-10 on page 5-49.
- ➔ Observe travel tables on page 5-4.

The positioner is mounted to the rotary actuator using two pairs of brackets.

Prior to attaching the positioner to the SAMSON Type 3278 Rotary Actuator, mount the associated adapter (5) to the free end of the rotary actuator shaft.

i Note

On mounting the positioner as described below, it is important to observe the actuator's direction of rotation.

1. Place follower clamp (3) on the slotted actuator shaft or spacer (5).
2. Place coupling wheel (4) with flat side facing the actuator on the follower clamp (3). Align slot so that it matches the direction of rotation when the valve is in its closed position (see Fig. 5-23).
3. Fasten the coupling wheel (4) and follower clamp (3) tightly onto the actuator shaft using screw (4.1) and disk spring (4.2).
4. Fasten the bottom pair of brackets (10.1) with the bends pointing either facing to the inside or to the outside (depending on the actuator size) onto the actuator hous-

ing. Position the top pair of brackets (10) and fasten.

5. Mount connecting plate (6) or pressure gauge bracket (7) with pressure gauges on the positioner. Make sure that the two seals are seated properly. Double-acting springless rotary actuators require the use of a reversing amplifier on the connection side of the positioner housing (see Chapter 5.6.7).
6. Unscrew the standard follower pin (2) from the positioner's **M** lever (1). Use the metal follower pin (\varnothing 5 mm) included in the mounting kit and screw tight into the hole for pin position **90°**.
7. Place positioner on the top bracket (10) and tighten. Taking the actuator's direction of rotation into account, adjust lever (1) so that it engages in the slot of the coupling wheel (4) with its follower pin (Fig. 5-23). It must be guaranteed that the lever (1) is parallel to the long side of the

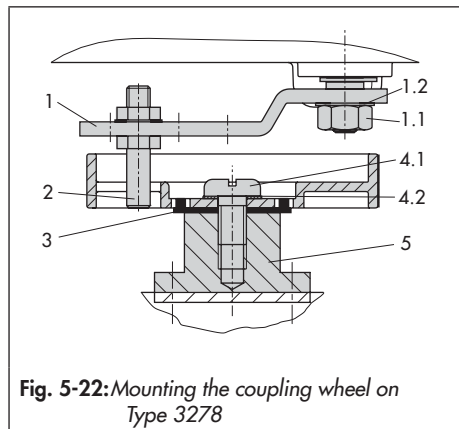
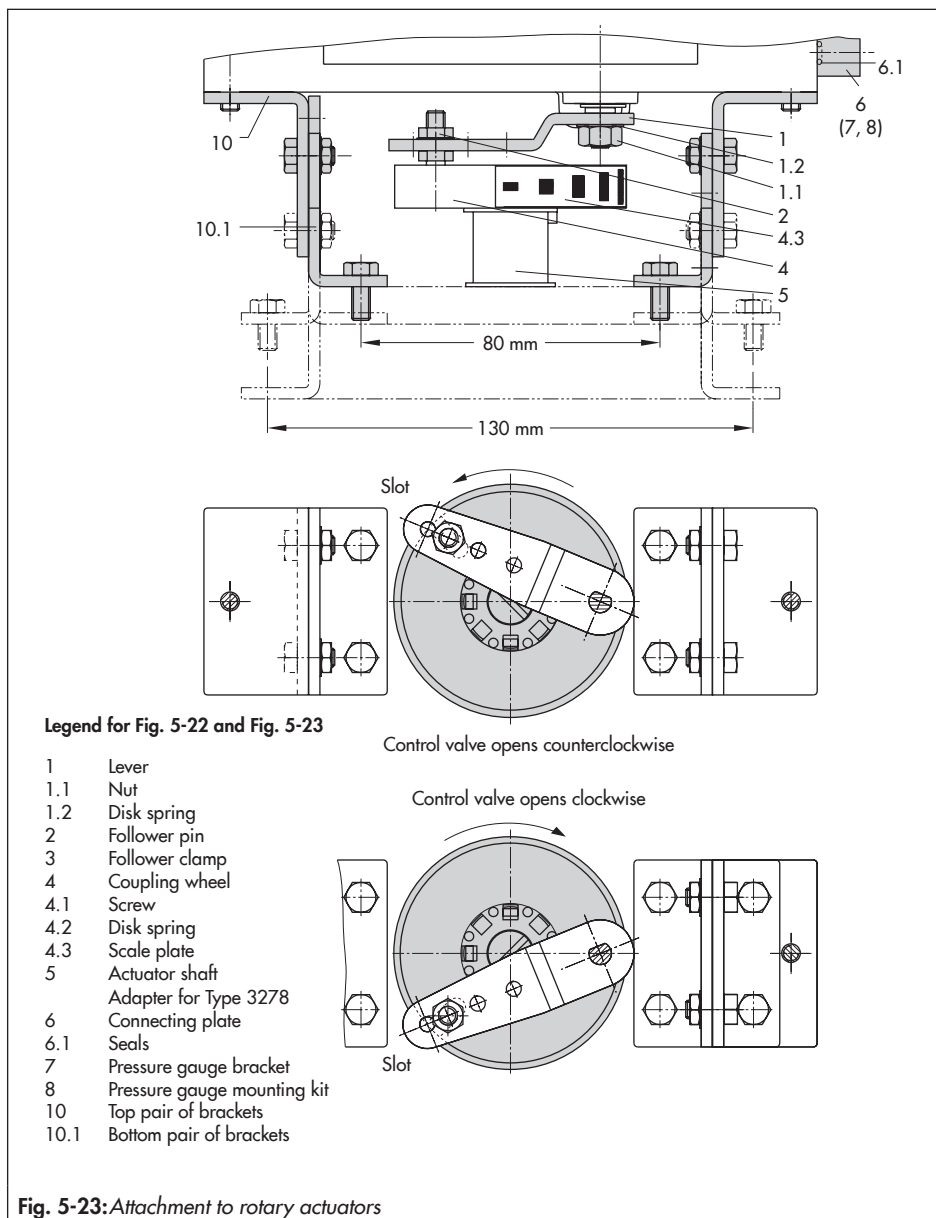

Fig. 5-22: Mounting the coupling wheel on Type 3278



Installation

positioner when the actuator is at half its angle of rotation.

- Stick the scale plate (4.3) on the coupling wheel so that the arrow tip indicates the closed position and it can be easily read when the valve is installed.

b) Heavy-duty version

i Note

We recommend using a volume restriction (see section 5.5) for actuators with a volume of less than 300 cm³.

→ See Fig. 5-25

→ Required mounting parts and accessories: Table 5-10 on page 5-49.

Both mounting kits contain all the necessary mounting parts. The parts for the actuator size used must be selected from the mounting kit.

Prepare actuator and mount possibly required adapter supplied by the actuator manufacturer.

- Seal the signal pressure output at the back of the positioner with the screw plug (4, order no. 0180-1254) and the associated O-ring (order no. 0520-0412) if the screw plug is not yet in place.
- Mount the housing (10) onto the rotary actuator. In case of VDI/VDE attachment, place spacers (11) underneath, if necessary.

- For **SAMSON Type 3278 and VETEC S160 Rotary Actuators**, fasten the adapter (5) onto the free end of the shaft and for **VETEC R Actuator**, place on the adapter (5.1). For **Type 3278, VETEC S160** and **VETEC R Actuators**, place on the adapter (3). For **Type 3278, VETEC S160** and **VETEC R Actuators**, place on the adapter (3). For VDI/VDE version, this step depends on the actuator size.
- Stick adhesive label (4.3) onto the coupling in such a manner that the yellow part of the sticker is visible in the window of the housing when the valve is OPEN. Adhesive labels with explanatory symbols are enclosed and can be stuck on the housing, if required.
- Fasten coupling wheel (4) on the slotted actuator shaft or adapter (3) using screw (4.1) and disk spring (4.2).

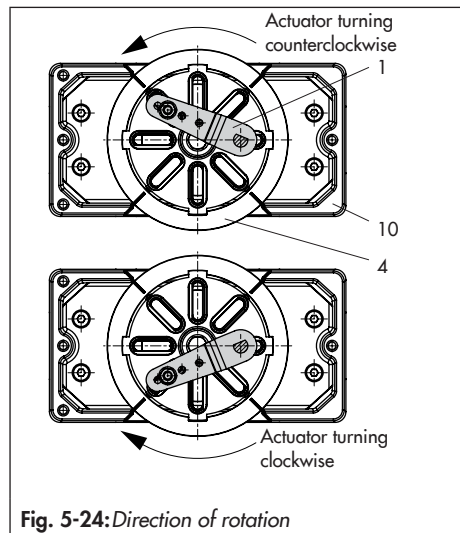

Fig. 5-24: Direction of rotation

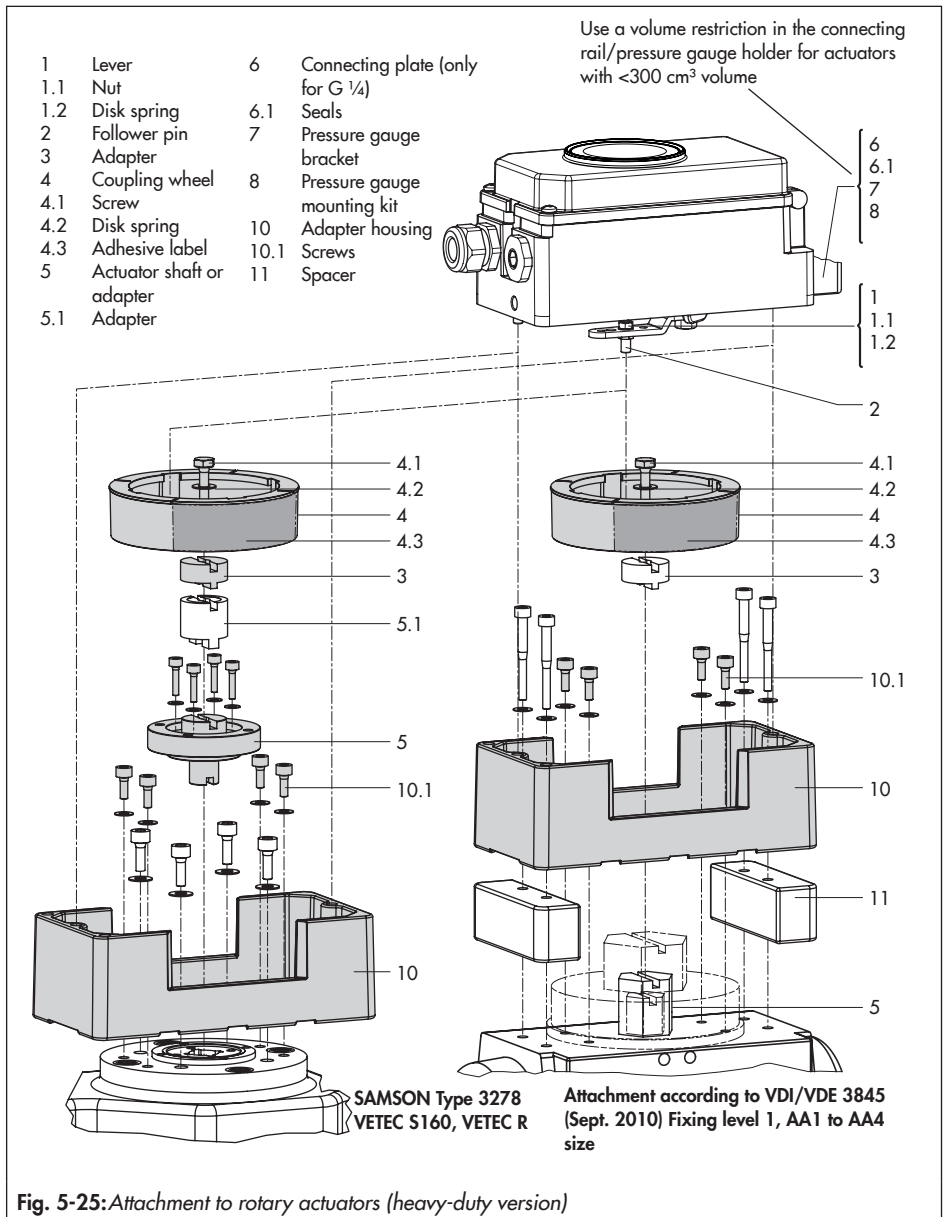

Fig. 5-25: Attachment to rotary actuators (heavy-duty version)

Installation

- Unscrew the standard follower pin (2) from the positioner's M lever (1). Attach the follower pin (Ø5 mm) included in the mounting kit to pin position 90°.
- Mount connecting plate (6) for required G ¼ connecting thread or pressure gauge bracket (7) with pressure gauges on the positioner. Make sure that the two seals (6.1) are seated properly. Double-acting springless rotary actuators require the use of a reversing amplifier on the connection side of the positioner housing (see Chapter 5.6.7).
- Place positioner on housing (10) and screw it tight. Taking the actuator's direction of rotation into account, adjust lever (1) so that it engages in the correct slot with its follower pin (Fig. 5-24).

5.6.7 Reversing amplifier for double-acting actuators

For the use with double-acting actuators, the positioner must be fitted with a reversing amplifier:

- SAMSON Type 3710 Reversing Amplifier, ► EB 8392

The following applies to all reversing amplifiers:

The signal pressure of the positioner is supplied at the output 1 of the reversing amplifier. An opposing pressure, which equals the required supply pressure (Z) when added to the pressure at output 1, is applied at output 2.

The following relationship applies:

output 1 + output 2 = Supply pressure (Z).

Connect output 1 to the signal pressure connection on the actuator that causes the valve to open when the pressure rises.

Connect output 2 to the signal pressure connection on the actuator that causes the valve to close when the pressure rises.

5.6.8 Attaching positioners with stainless steel housings

Positioners with stainless steel housings require mounting parts that are completely made of stainless steel or free of aluminum.

i Note

The pneumatic connecting plate and pressure gauge bracket are available in stainless steel (order numbers listed below). The Type 3710 Pneumatic Reversing Amplifier is also available in stainless steel.

Connecting plate (stainless steel 1.4404)	G ¼ ¼ NPT	1400-7476 1400-7477
Pressure gauge bracket (stainless steel 1.4408)	G ¼ ¼ NPT	1402-0265 1400-7108

Table 5-4 to Table 5-10 apply for attaching positioners with stainless steel housings with the following restrictions:

Direct attachment

All mounting kits from Table 5-5 and Table 5-6 can be used. The connection block is not required. The stainless steel version of the

pneumatic connecting plate routes the air internally to the actuator.

Attachment according to IEC 60534-6 (NAMUR rib or attachment to rod-type yokes)

All mounting kits from Table 5-7 can be used. Connecting plate in stainless steel.

Attachment to rotary actuators

All mounting kits from Table 5-10 can be used except for the heavy-duty version. Connecting plate in stainless steel.

5.6.9 Air purging function for single-acting actuators

The instrument air leaving the positioner is diverted to the actuator spring chamber to provide corrosion protection inside the actuator. Observe the following:

Vent opening

The vent opening must not be sealed. The positioner version "exhaust air port with thread, back of positioner sealed" is not suitable for use with air purging.

Direct attachment to Type 3277-5 (stem extends FA/stem retracts FE)

The air purging function is automatically provided.

Direct attachment to Type 3277, 175 to 750 cm²

Stem extends: remove the stopper (12.2, Fig. 5-9) at the black connection block and make a pneumatic connection to the spring chamber on the vented side.

Stem retracts: the air purging function is automatically provided.

Attachment according to IEC 60534-6 (NAMUR rib or attachment to rod-type yokes) and to rotary actuators

The positioner requires an additional port for the exhaust air that can be connected over piping. An adapter available as an accessory is used for this purpose:

Threaded bushing (M20x1.5)	G ¼	0310-2619
	¼ NPT	0310-2550

i Note

The adapter uses one of the M20x1.5 connections in the housing which means only one cable gland can be installed.

Should other valve accessories be used which vent the actuator (e.g. solenoid valve, volume booster, quick exhaust valve), this exhaust air must also be included in the purging function. The connection over the adapter at the positioner must be protected with a check valve (e.g. screw fitting with restriction G ¼, order no. 1991-5777) or ¼ NPT (order no. 1992-3178) mounted in the piping. Otherwise the pressure in the positioner housing would rise above the ambient pressure and damage the positioner when the exhausting components respond suddenly.

5.7 Establishing pneumatic connections

⚠ WARNING

Risk of injury by possible movement of exposed parts (positioner, actuator or valve) after connecting the signal pressure.

→ Do not touch or block exposed moving parts.

ⓘ NOTICE

Incorrect connection of the supply air will damage the positioner and will lead to malfunction.

→ Screw the screw fittings into the connecting plate, pressure gauge mounting block or connection block from the accessories.

The pneumatic ports are located on the back of the positioner (see Fig. 5-26).

ⓘ NOTICE

Risk of malfunction due to failure to comply with air quality requirements.

- Only use supply air that is dry and free of oil and dust.
- Read the maintenance instructions for upstream pressure reducing stations.
- Blow through all air pipes and hoses thoroughly before connecting them.

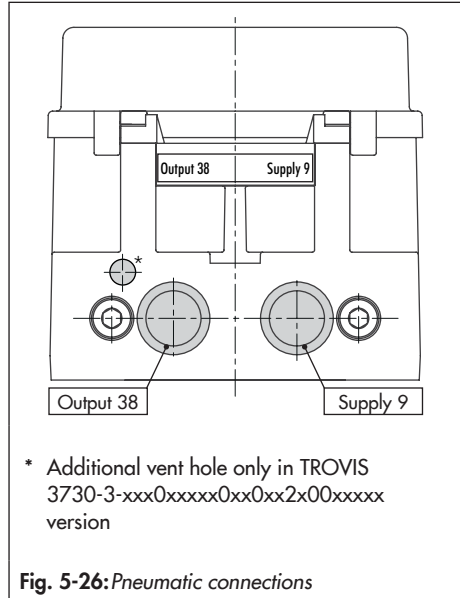

5.7.1 Supply air

⚠ WARNING

Sudden loud noise when the pneumatic actuator vents.

→ Wear hearing protection when working near the valve.

NOTICE

Risk of malfunction due to incorrect sequence of mounting, installation and start-up.

- Observe the following sequence.
1. Remove the protective caps from the pneumatic connections.
 2. Mount the positioner on the valve.
 3. Connect the supply air.
 4. Connect the electrical power.
 5. Perform settings.

The pneumatic connections in the connecting plate, pressure gauge mounting block and connection block are optionally designed as a bore with ¼ NPT or G ¼ thread. Customary fittings for metal or copper tubing or plastic hoses can be used.

→ Read instructions in Chapter 5.7.

5.7.2 Signal pressure connection

The signal pressure connection depends on how the positioner is mounted onto the actuator:

Type 3277 Actuator

→ The signal pressure connection is fixed.

Attachment according to IEC 60534-6

- For "actuator stem retracts" fail-safe action: connect the signal pressure to the connection on top of the actuator.
- For "actuator stem extends" fail-safe action: connect the signal pressure to the connection on bottom of the actuator.

Rotary actuators (heavy-duty version)

→ For rotary actuators, the manufacturer's specifications for connection apply.

5.7.3 Output signal display



To monitor the supply air and signal pressure, SAMSON recommends mounting pressure gauges (see accessories in Chapter 5.9).

Mounting the pressure gauges:

→ See Chapter Fig. 5-10 and 5.6.2.

5.7.4 Supply pressure

The required supply air pressure depends on the bench range and the actuator's direction of action (fail-safe action).

The bench range is written on the nameplate either as the bench range or signal pressure range depending on the actuator. The direction of action is marked FA or FE or by a symbol.

Actuator stem extends FA (AIR TO OPEN)

Fail-close (for globe and angle valves):

→ Required supply pressure = Upper bench range value + 0.2 bar, at least 1.4 bar.

Actuator stem retracts FE (AIR TO CLOSE)

Fail-open (for globe and angle valves):

For tight-closing valves, the maximum signal pressure $p_{st,max}$ is roughly estimated as follows:

Installation

$$p_{st_{max}} = F + \frac{d^2 \cdot \pi \cdot \Delta p}{4 \cdot A} \quad [\text{bar}]$$

d = Seat diameter [cm]

Δp = Differential pressure across the valve [bar]

A = Actuator area [cm²]

F = Upper bench range value of the actuator [bar]

If there are no specifications, calculate as follows:

→ Required supply pressure = Upper bench range value + 1 bar

5.8 Establishing electrical connections

⚠ DANGER

Risk of fatal injury due to the formation of an explosive atmosphere.

→ For installation in hazardous areas, observe the relevant standards that apply in the country of use.

Standard applicable in Germany:
EN 60079-14 (VDE 0165, Part 1)
Explosive Atmospheres – Electrical Installations Design, Selection and Erection.

⚠ WARNING

Incorrect electrical connection will render the explosion protection unsafe.

→ Adhere to the terminal assignment.

→ Do not undo the enameled screws.

⚠ WARNING

Intrinsic safety rendered ineffective in intrinsically safe devices.

→ Only connect intrinsically safe devices intended for use in intrinsically safe circuits to certified intrinsically safe input-connected units.

→ Do not place intrinsically safe devices back into operation that were connected to intrinsically safe input-connected units without certification.

→ Do not exceed the maximum permissible electric values specified in the EU type examination certificates when interconnecting intrinsically safe electrical equipment (U_i or U_o , I_i or I_o , P_i or P_o , C_i or C_o and L_i or L_o).

⚠ WARNING

Sudden loud noise when the pneumatic actuator vents.

→ Wear hearing protection when working near the valve.

Selecting cables and wires

→ Observe the relevant clauses of EN 60079-14 for installation of intrinsically safe circuits.

→ Seal cable entries left unused with plugs.

→ Fit equipment used in ambient temperatures below -20 °C with metal cable entries.

Equipment with type of protection Ex ec

In equipment operated according to type of protection Ex ec (increased safety), circuits may be connected, interrupted or switched while energized only during installation, maintenance or repair.

Use certified cable glands and blanking plugs with appropriate type of protection and IP rating $\geq 6X$ and suitable for the certified temperature range.

The signal circuit is connected using screw terminals (terminal 11/12) for electrical conductors with a wire cross-section from 0.2 to 2.5 mm². The tightening torque is 0.5 to 0.6 Nm.

Equipment with type of protection Ex ia

In equipment operated according to type of protection Ex ia (intrinsic safety), circuits may be connected, interrupted or switched while energized.

Opening the enclosure cover in potentially explosive dust atmospheres during operation may cause the explosion protection to become ineffective.

For applications in dust group IIIC, the supplied cable glands, blanking plugs and connectors must be replaced with certified cable glands, blanking plugs and connectors. The cable glands, blanking plugs and connectors must be suitable for the certified temperature range and have a minimum IP rating of IP54.

The signal circuit is connected using screw terminals (terminal 11/12) for electrical conductors with a wire cross-section from 0.2 to 2.5 mm². Tightening torque 0.5 to 0.6 Nm.

Equipment with type of protection Ex t

In equipment operated according to type of protection Ex t (protection by enclosure), circuits may be connected, interrupted or switched while energized only during installation, maintenance or repair.

Opening the enclosure cover in potentially explosive dust atmospheres during operation may cause the explosion protection to become ineffective.

Use certified cable glands and blanking plugs with appropriate type of protection and IP rating $\geq 6X$ and suitable for the certified temperature range.

The signal circuit is connected using screw terminals (terminal 11/12) for electrical conductors with a wire cross-section from 0.2 to 2.5 mm². The tightening torque is 0.5 to 0.6 Nm.

5.8.1 Cable entry with cable gland

The housing of the TROVIS 3730-3 Positioner has two threaded boreholes, which can be fitted with cable glands as required.

- ➔ The cable gland version depends on the ambient temperature range (see technical data in the 'Design and principle of operation' chapter).
- ➔ The screw terminals are designed for wire cross-sections of 0.2 to 2.5 mm² (tightening torque 0.5 Nm).
- ➔ Connect **one** current source at the maximum.

Installation

In general, it is not necessary to connect the device to a bonding conductor. Should this be required, however, this conductor can be connected inside or outside of the device.

Adapter M20x1.5 to ½ NPT

Powder-coated aluminum
Stainless steel

0310-2149
1400-7114

5.8.2 Electrical power

ⓘ NOTICE

Risk of malfunction due to incorrect sequence of mounting, installation and start-up.

→ Observe the following sequence.

1. Remove the protective caps from the pneumatic connections.
2. Mount the positioner on the valve.
3. Connect the supply air.
4. Connect the electrical power.
5. Perform settings.

→ Connect options (see the 'Design and principle of operation' section) as shown in Fig. 5-28 to Fig. 5-33, if necessary.

→ Connect the electrical power (mA signal) as shown in Fig. 5-27.

Accessories

Cable glands M20x1.5	Order no.
Black plastic (6 to 12 mm clamping range)	8808-1011
Blue plastic (6 to 12 mm clamping range)	8808-1012
Nickel-plated brass (6 to 12 mm clamping range)	1890-4875
Nickel-plated brass (10 to 14 mm clamping range)	1992-8395
Stainless steel 1.4305 (8 to 14.5 mm clamping range)	8808-0160

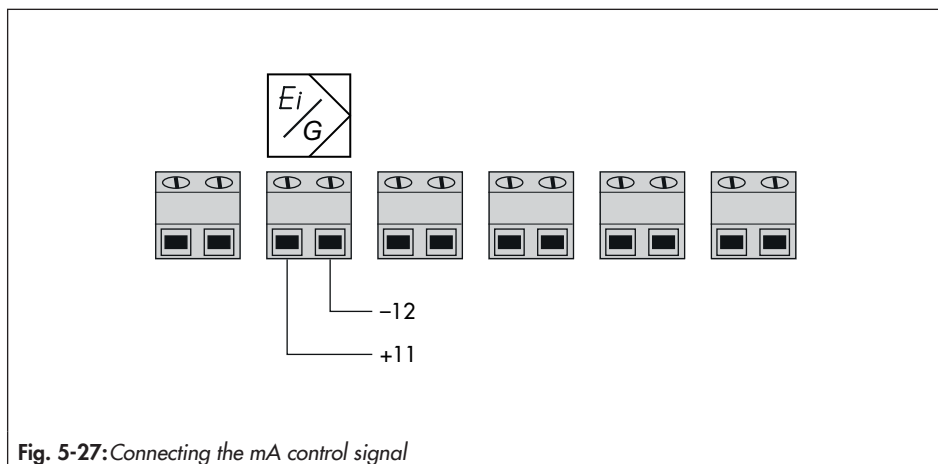

Fig. 5-27: Connecting the mA control signal

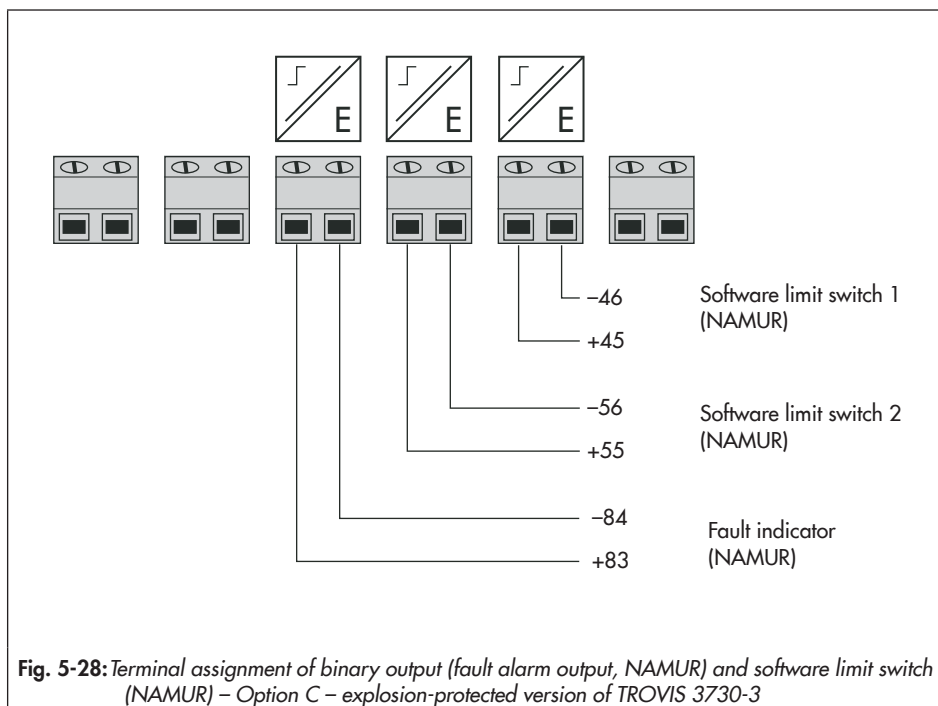

Fig. 5-28: Terminal assignment of binary output (fault alarm output, NAMUR) and software limit switch (NAMUR) – Option C – explosion-protected version of TROVIS 3730-3

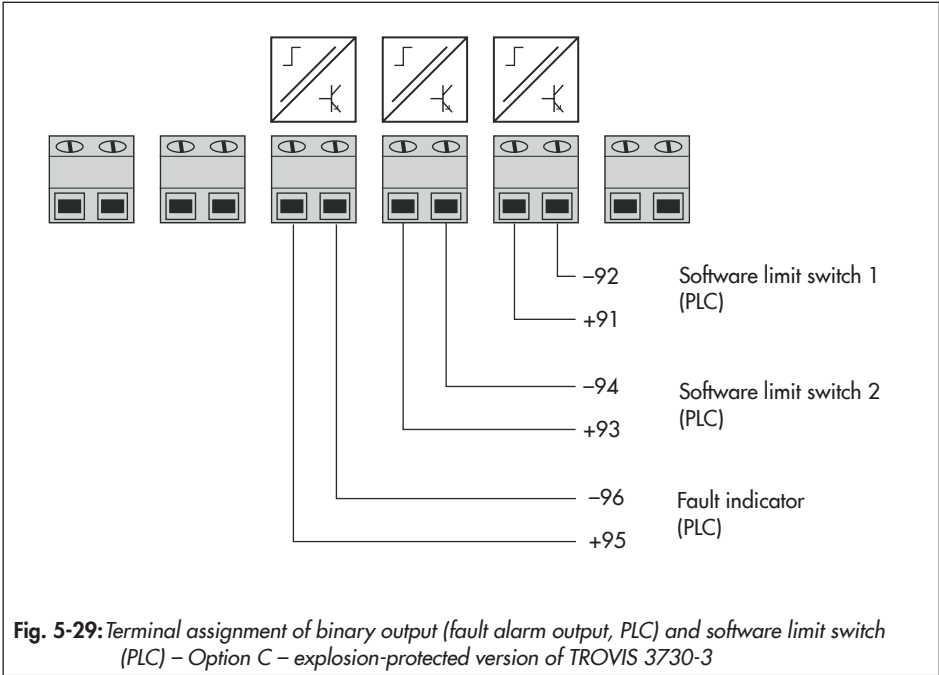

Fig. 5-29: Terminal assignment of binary output (fault alarm output, PLC) and software limit switch (PLC) – Option C – explosion-protected version of TROVIS 3730-3

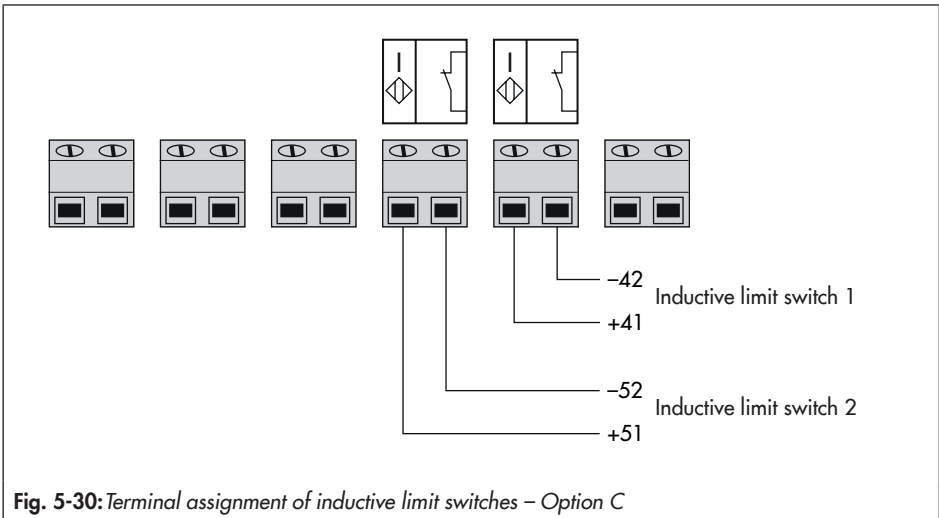

Fig. 5-30: Terminal assignment of inductive limit switches – Option C

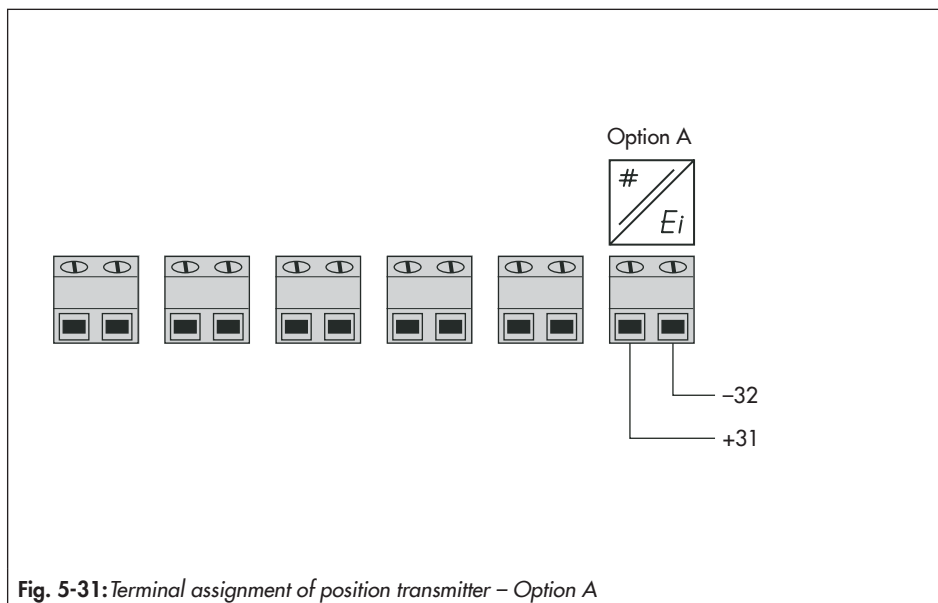

Fig. 5-31: Terminal assignment of position transmitter – Option A

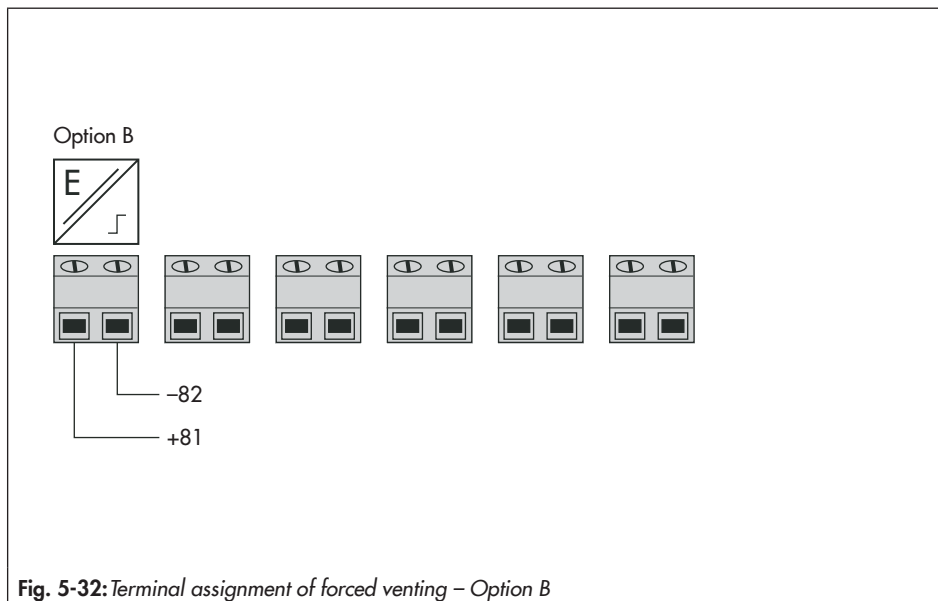

Fig. 5-32: Terminal assignment of forced venting – Option B

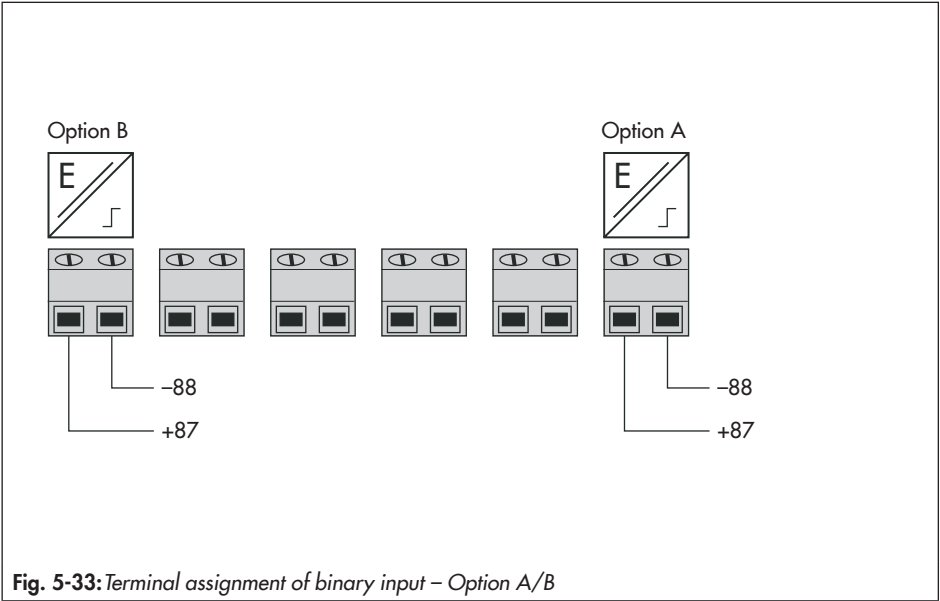

Fig. 5-33: Terminal assignment of binary input – Option A/B

5.8.3 Establishing HART® communication

Communication between computer and positioner using an FSK modem or handheld communicator (if necessary, using an isolation amplifier) is based on the HART® protocol.

Viator FSK modem

- USB No explosion protection Order no. 100172502

If the load impedance of the controller or control station is too low, an isolation amplifier must be connected between controller and positioner (interfacing as for positioner connected in hazardous areas). See Fig. 5-34.

If the positioner is used in hazardous areas, an explosion-protected isolation amplifier must be used.

Using the HART® protocol, all connected control room and field units can be addressed individually with their address using a standard bus.

Standard bus:

In the standard bus mode, the positioner follows the analog set point. The bus address/polling address has to be within a range of 1 to 15.

When communication errors occur:

Communication errors may occur when the process controller/control station output is not HART®-compatible.

Alternatively, a 250 Ω resistor can be connected in series and a 22 μF capacitor can be connected in parallel to the analog output of positioners without explosion protection and positioners with type of protection Ex tb (Fig. 5-35). The load for the controller output will increase as a result.

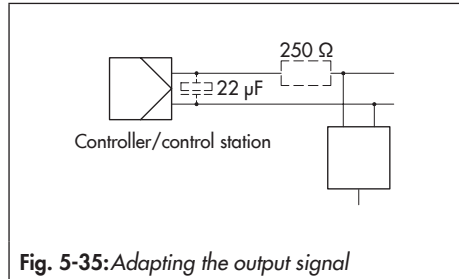

Fig. 5-35: Adapting the output signal

5.8.4 Switching amplifier according to EN 60947-5-6

For operation of the NAMUR limit switches, switching amplifiers must be connected in the output circuit. They must comply with the limit values of the output circuits conforming to EN 60947-5-6.

➔ Observe the relevant regulations for installation in hazardous areas.

For applications in safe areas (non-hazardous areas), software limit switches (PLC) can be directly interconnected to the binary input of the PLC in accordance with IEC 61131. This applies to the standard operating range for digital inputs according to Clause 5.2.1.2 of IEC 61131-2 with the rated voltage of 24 V DC.

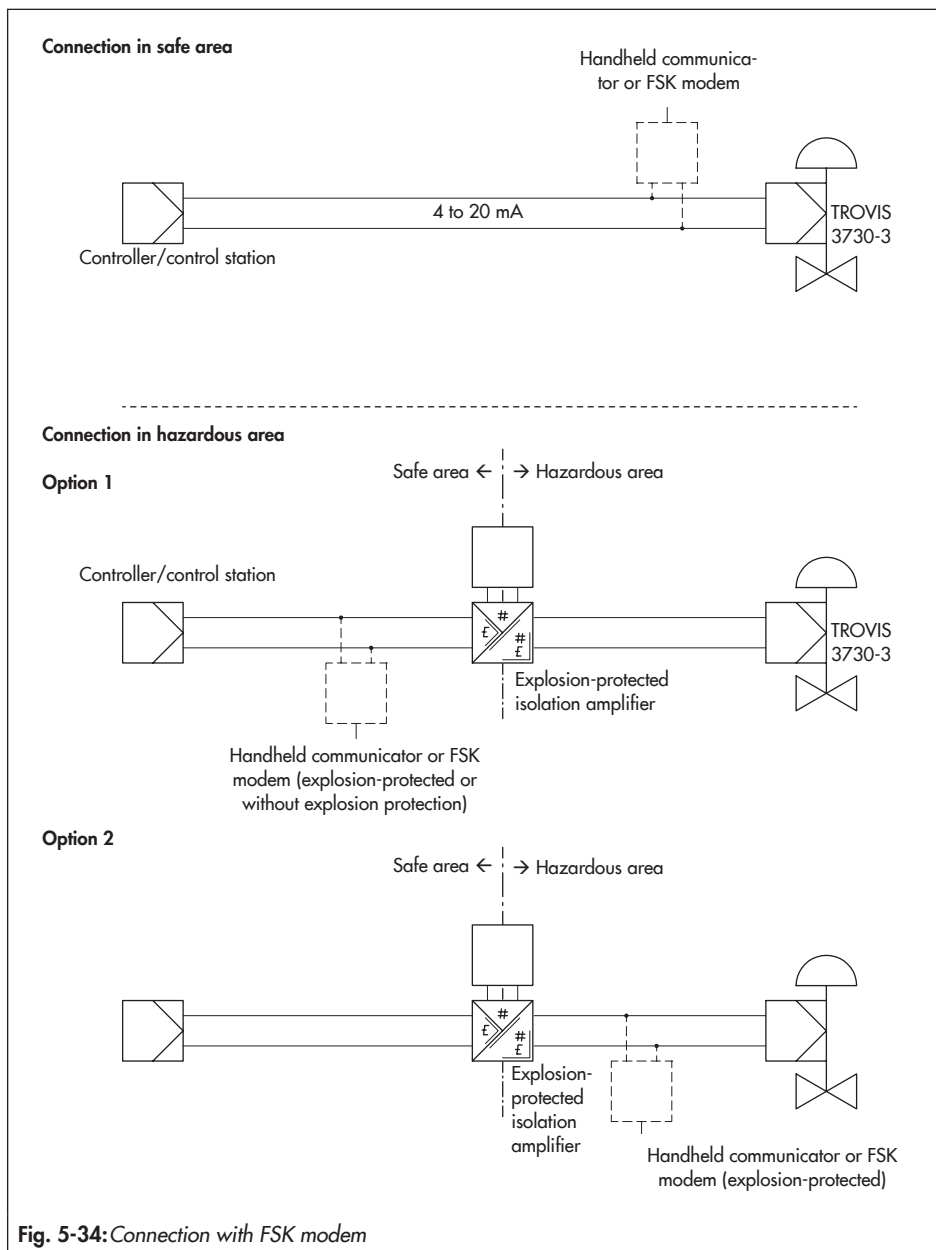

Fig. 5-34: Connection with FSK modem

5.9 Accessories

Table 5-4: *General accessories*

Designation	Order no.	
Reversing amplifier for double-acting actuators	Type 3710	
M20x1.5 cable gland	Black plastic (6 to 12 mm clamping range)	8808-1011
	Blue plastic (6 to 12 mm clamping range)	8808-1012
	Nickel-plated brass (6 to 12 mm clamping range)	1890-4875
	Nickel-plated brass (10 to 14 mm clamping range)	1992-8395
	Stainless steel 1.4305 (8 to 14.5 mm clamping range)	8808-0160
Adapter M20x1.5 to ½ NPT	Powder-coated aluminum	0310-2149
	Stainless steel	1400-7114
M lever	0510-0510	
L lever	0510-0511	
XL lever	0510-0512	
XXL lever	0510-0525	
Volume restriction	For mounting on the connection block	100041955
	For mounting on the connecting plate/pressure gauge bracket	100041162
Isolated USB interface adapter (SSP interface to USB port on a computer)	1400-9740	
Viator USB FSK modem	100172502	
TROVIS-VIEW 6661 (www.samsongroup.com > Downloads > Software & Drivers > TROVIS-VIEW)		

Table 5-5: Direct attachment to Type 3277-5 (see Chapter 5.6.1 a))

Designation		Order no.		
Mounting parts	Version resistant to seawater for actuators up 120 cm ² or smaller	100249532		
Accessories for actuator	New switchover plate for Type 3277-5xxxxx.01 Actuator (new) ¹⁾	1400-6822		
	New connecting plate for Type 3277-5xxxxx.01 Actuator (new) ¹⁾ , G 1/8 and 1/8 NPT	1400-6823		
Accessories for positioner	Connecting plate (6)	G 1/4	Standard	1400-7461
			Stainless steel	1400-7476
		1/4 NPT	Standard	1400-7462
			Stainless steel	1400-7477
	Pressure gauge bracket (7)	G 1/4	Standard	1400-7458
			Stainless steel	1402-1370
		1/4 NPT	Standard	1400-7459
			Stainless steel	1402-1369
	Pressure gauge mounting kit (8) up to max. 6 bar		Stainless steel/brass	1402-1637
			Stainless steel/stainless steel	1402-1638
Volume restriction for connecting plate/pressure gauge bracket			100041162	

¹⁾ Only new switchover and connecting plates can be used with new actuators (index .01). Old and new plates are not interchangeable.

Table 5-6: Direct attachment to Type 3277 (see Chapter 5.6.1 b))

Mounting parts/accessories		Order no.
Version resistant to seawater for actuators 175, 240, 350, 355, 700, 750 cm ²		100184391
Connection block with seals and screw	G ¼	1400-8819
	¼ NPT	1402-0901
Connection block to attach solenoid valve	G ¼	1400-8817
	¼ NPT	1400-8818
Pressure gauge mounting kit up to max. 6 bar	Stainless steel/brass	1402-1637
	Stainless steel/stainless steel	1402-1638
Volume restriction for connection block (recommended for <240 cm ²)		100041955
Piping with screw fittings ¹⁾		Order no.
Actuator (175 cm ²), steel	G ¼/G ¾	1402-0970
	¼ NPT/¾ NPT	1402-0976
Actuator (175 cm ²), stainless steel	G ¼/G ¾	1402-0971
	¼ NPT/¾ NPT	1402-0978
Actuator (240 cm ²), steel	G ¼/G ¾	1400-6444
	¼ NPT/¾ NPT	1402-0911
Actuator (240 cm ²), stainless steel	G ¼/G ¾	1400-6445
	¼ NPT/¾ NPT	1402-0912
Actuator (350 cm ²), steel	G ¾/G ¾	1400-6446
	¾ NPT/¾ NPT	1402-0913
Actuator (350 cm ²), stainless steel	G ¾/G ¾	1400-6447
	¾ NPT/¾ NPT	1402-0914
Actuator (355 cm ²), steel	G ¾/G ¾	1402-0972
	¾ NPT/¾ NPT	1402-0979
Actuator (355 cm ²), stainless steel	G ¾/G ¾	1402-0973
	¾ NPT/¾ NPT	1402-0980
Actuator (700 cm ²), steel	G ¾/G ¾	1400-6448
	¾ NPT/¾ NPT	1402-0915
Actuator (700 cm ²), stainless steel	G ¾/G ¾	1400-6449
	¾ NPT/¾ NPT	1402-0916
Actuator (750 cm ²), steel	G ¾/G ¾	1402-0974
	¾ NPT/¾ NPT	1402-0981
Actuator (750 cm ²), stainless steel	G ¾/G ¾	1402-0975
	¾ NPT/¾ NPT	1402-0982

¹⁾ For "actuator stem retracts" direction of action;
with air purging of the top diaphragm chamber;
air purging of the spring chamber for "actuator stem extends" direction of action

Table 5-7: Attachment to NAMUR rib or attachment to rod-type yokes ¹⁾ according to IEC 60534-6 (Chapter 5.6.2)

Travel in mm	Lever	For actuator	Order no.
7.5	S	Type 3271-5 with 60/120 cm ² on Type 3510 Micro-flow Valve	1402-0478
5 to 50	M ²⁾	Actuators from other manufacturers and Type 3271 with 120 to 750 cm ² effective areas	1400-7454
14 to 100	L	Actuators from other manufacturers and Type 3271 with 1000 and 1400-60 cm ²	1400-7455
30 or 60	L	Type 3271, 1400-120 and 2800 cm ² versions with 30/60 mm travel ³⁾	1400-7466
		Mounting brackets for Emerson and Masoneilan linear actuators (in addition, a mounting kit according to IEC 60534-6 is required depending on the travel). See rows above.	1400-6771
		Valtek Type 25/50	1400-9554
40 to 200	XL	Actuators from other manufacturers and Type 3271 with 1400-120 and 2800 cm ² and with 120 mm travel	1400-7456
Accessories			Order no.
Connecting plate	G ¼	Standard	1400-7461
		Stainless steel	1400-7476
	¼ NPT	Standard	1400-7462
		Stainless steel	1400-7477
Pressure gauge bracket	G ¼	Standard	1400-7458
		Stainless steel	1402-1370
	¼ NPT	Standard	1400-7459
		Stainless steel	1402-1369
Pressure gauge mounting kit up to max. 6 bar		Stainless steel/brass	1402-1637
		Stainless steel/stainless steel	1402-1638
Volume restriction for connection block (recommended for actuators with <300 cm ³ volume)			100041955

Installation

- 1) 20 to 35 mm rod diameter
- 2) M lever is mounted on basic device (included in the scope of delivery)
- 3) In conjunction with Type 3273 Side-mounted Handwheel with 120 mm rated travel, additionally one bracket (0300-1162) and two countersunk screws (8330-0919) are required.

Table 5-8: Attachment according to VDI/VDE 3847-1 (see Chapter 5.6.4)

Mounting parts			Order no.
VDI/VDE 3847 interface adapter			1402-0257
Connecting plate, including connection for air purging of actuator spring chamber	Aluminum	ISO 228/1-G ¼	1402-0268
		¼-18 NPT	1402-0269
	Stainless steel	ISO 228/1-G ¼	1402-0270
		¼-18 NPT	1402-0271
Mounting kit for attachment to SAMSON Type 3277 Actuator with 175 to 750 cm ²			1402-0868
Mounting kit for attachment to SAMSON Type 3271 Actuator or third-party actuators			1402-0869
Travel pick-off for valve travel up to 100 mm			1402-0177
Travel pick-off for 100 to 200 mm valve travel (SAMSON Type 3271 Actuator only)			1402-0178

Table 5-9: Attachment according to VDI/VDE 3847-2 (see Chapter 5.6.5)

Designation		Order no.
Mounting parts	Mounting block for PFEIFFER Type 31a (edition 2020+) Rotary Actuators with blank plate for solenoid valve interface, Ematal	100049296
	Dummy plate for solenoid valve interface (sold individually)	1402-1290
	Adapter bracket for Series 3730 (VDI/VDE 3847)	1402-0257
	Adapter bracket for Series 3730 and Type 3710 (DAP/PST)	1402-1590

Accessories for actuator	Shaft adapter AA1	1402-1617
	Shaft adapter AA2	1402-1616
	Shaft adapter AA4	1402-1888

Table 5-10: Attachment to rotary actuators (see Chapter 5.6.6)

Mounting parts/accessories		Order no.		
Attachment according to VDI/VDE 3845 (September 2010), actuator surface corresponds to fixing level 1				
	Size AA1 to AA4, version with CrNiMo steel bracket	1400-7448		
	Size AA1 to AA4, heavy-duty version, powder-coated aluminum	1400-9244		
	Size AA1 to AA4, heavy-duty version, stainless steel (316)	1402-1592		
	Size AA5, heavy-duty version (e.g. Air Torque 10 000)	1400-9542		
	Bracket surface corresponds to fixing level 2, heavy-duty version	1400-9526		
Attachment for rotary actuators with max. 180° opening angle, fixing level 2		1400-8815 and 1400-9837		
Attachment to SAMSON Type 3278 with 160/320 cm ² , CrNiMo steel bracket		1400-7614		
Attachment to SAMSON Type 3278 with 160 cm ² and to VETEC Type S160, Type R and Type M, heavy-duty version		1400-9245		
Attachment to SAMSON Type 3278 with 320 cm ² and to VETEC Type S320, heavy-duty version		1400-5891 and 1400-9526		
Attachment to Camflex II		1400-9120		
Accessories	Connecting plate	G ¼	Standard	1400-7461
			Stainless steel	1400-7476
		¼ NPT	Standard	1400-7462
			Stainless steel	1400-7477
	Pressure gauge bracket	G ¼	Standard	1400-7458
			Stainless steel	1402-1370
		¼ NPT	Standard	1400-7459
			Stainless steel	1402-1369
	Pressure gauge mounting kit up to max. 6 bar		Stainless steel/brass	1402-1637
			Stainless steel/stainless steel	1402-1638
	Volume restriction for connection block (recommended for actuators with <300 cm ³ volume)		100041955	

6 Operation

⚠ WARNING

Sudden loud noise when the pneumatic actuator vents.

→ Wear hearing protection when working near the valve.

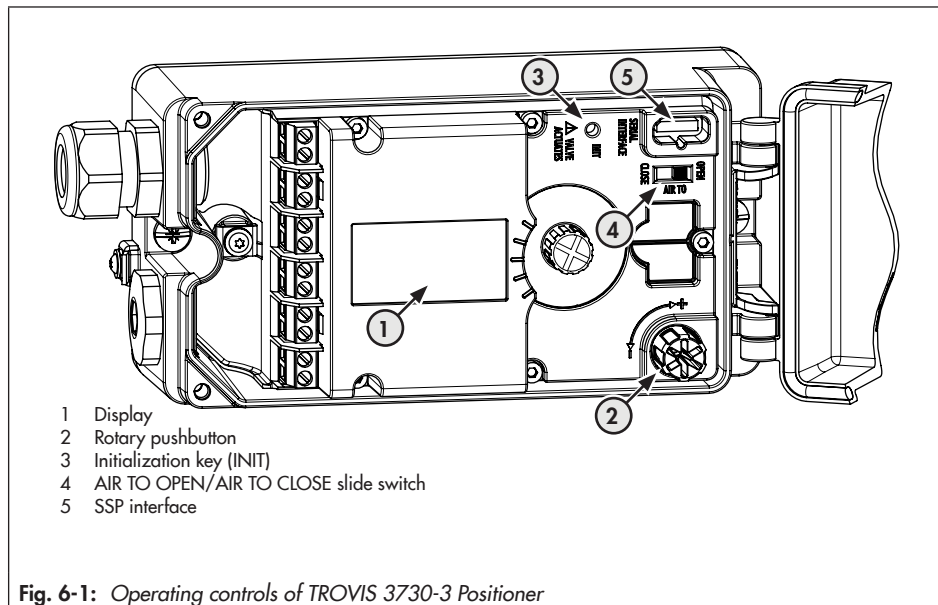

6.1 Rotary pushbutton

The rotary pushbutton for on-site operation is located next to the display (bottom right or top left, depending on the mounting position).

- ⊗ Turn: select menu item, parameters or values.
- ⊗ Press: confirm setting.
- ⊗ Keep pressed down for two seconds: return to menu level (*ESC* with progress bar appears).

6.2 AIR TO OPEN/AIR TO CLOSE slide switch

→ See the 'Start-up and configuration' chapter.

6.3 Initialization key (INIT)

⚠ WARNING

Risk of injury by exposed moving parts on the positioner, actuator or valve.

→ *Do not touch or block exposed moving parts.*

⚠ NOTICE

The process is disturbed by the movement of the actuator or valve.

→ *Do not perform the initialization while the process is running. First isolate the plant by closing the shut-off valves.*

For normal operation, simply start initialization by pressing the INIT key after mounting the positioner on the valve. In this case, the initialization is performed using the MAX initialization mode (see the 'Start-up and configuration' chapter). Additionally, the default settings in the parameter list (see Appendix A) apply.

Proceed as follows for fast initialization:

1. Mount the positioner on the valve.
2. Connect the supply air.
3. Connect the electrical power.
→ During the first start-up, the wizard is displayed (see the 'Start-up and configuration' chapter).
4. Set the ATO/ATC slider switch to match the valve's fail-safe position as described in Chapter 6.2.
5. Use a thin object to press the initialization key (INIT).

6.4 Display

i Note

The display's operating range is from -20 to $+65$ °C. The readability of the display is restricted outside this temperature range.

As soon as the electrical power (mA control signal) is connected, the **wizard** is displayed during the first start-up (see the 'Start-up and configuration' chapter) and, in all other cases, the **start screen** (Fig. 6-2, left) appears, which is marked by the reading number 0.1 to 0.99 (at the top right-hand corner of the display). Displayed icons provide information on the operating mode, status etc. (see Chapter 6.4.1). Press the **⊗** key to go from the start screen to the **menu level** (Fig. 6-2, right). All settings can be made and functions executed in the menu level. The 'Start-up and configuration' chapter contains a description of the basic start-up settings. A list of the menu structure and parameters for on-site operation is included in Appendix A.

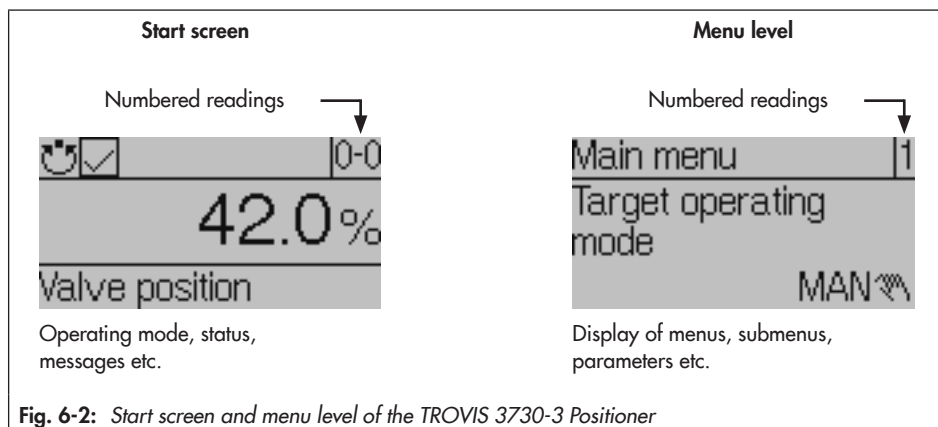

- Turn **⊗** clockwise to scroll through from reading 0.1 to 0.99. Readings 0.1 to 0.99 are hidden or shown depending on the positioner's operating mode, configuration, status etc.
- Press the **⊗** key to go from the **start screen** to the **menu level**.

Operation

Table 6-1: Readings on the start screen

View	Description	
0.1	Valve position	Reading in degrees (when the positioner has not yet been initialized)
0.2	Valve position	Reading in % (when the positioner has been initialized)
0.12	Set point	Reading in %
0.15	Set point deviation	Reading in %
0.20	Supply pressure	Reading in bar (only positioners with pressure sensors)
0.50	Reading of generated messages	
0.99	Press  to go the menu.	

1	2	3	4
Value			
Description			

- 1 Operating mode (see Table 6-2)
- 2 NAMUR status (see Table 6-3)
- 3 Other icons (see Table 6-4)
- 4 Numbered readings

Note





Some of the messages (reading 0.50) can be confirmed: in this case, select the message and press  (only possible when the configuration is enabled, see the 'Start-up and configuration' chapter).

Readings in the menu level

→ See Appendix A for the menu structure and parameters for on-site operation.

6.4.1 Display icons

Table 6-2: *Operating modes*

Icon	Operating mode	Description
	Automatic mode	The positioner is in closed-loop operation and follows the mA signal.
	Manual mode	The positioner follows the manual set point instead of the mA signal.
	SAFE (fail-safe position)	The positioner vents the pneumatic actuator at its pneumatic output.
	Open-loop control mode ¹⁾	The open-loop control mode allows the valve position to be adjusted manually (even when the positioner has not been initialized).
	Function mode	The positioner is being initialized or a test is in progress.

¹⁾ The open-loop control mode cannot be directly selected. It acts the same as the manual mode when the positioner has not yet been initialized.

Table 6-3: *NAMUR status*











Icon	Meaning
	Failure
	Function check
	Out of specification
	Maintenance demanded
	OK (no message)

Table 6-4: *Other icons*

Icon	Meaning
	Write protection, configuration not enabled
	Option A installed
	Option B installed
	Binary contact 1 active
	Binary contact 2 active
	Binary contact 3 active

7 Start-up and configuration

The work described in this chapter is to be performed only by personnel appropriately qualified to carry out such tasks.

DANGER

Risk of fatal injury due to the ignition of an explosive atmosphere.

- Observe EN 60079-14 (VDE 0165, Part 1) for work on the positioner in potentially explosive atmospheres.
 - Work in potentially explosive atmospheres is to be performed only by personnel who has undergone special training or instructions or who is authorized to work on explosion-protected devices in hazardous areas.
-

WARNING

Crush hazard arising from moving parts on the valve.

- Do not touch any moving valve parts while the control valve is in operation.
 - Before performing any mounting or installation work on the positioner, put the control valve out of operation by disconnecting and locking the supply air and control signal.
 - Do not impede the movement of the actuator and plug stem by inserting objects into the yoke.
-

WARNING

Sudden loud noise when the pneumatic actuator vents.

- Wear hearing protection when working near the valve.
-

Before start-up, make sure the following conditions are met:

- The positioner is properly mounted according to the instructions.
- The pneumatic and electrical connections have been performed according to the instructions.

NOTICE

Risk of malfunction due to incorrect sequence of mounting, installation and start-up.





→ Observe the following sequence.

1. Remove the protective caps from the pneumatic connections.
2. Mount the positioner on the valve.
3. Connect the supply air.
4. Connect the electrical power.
5. Perform settings.

Once the mounting and start-up activities have been completed, you can start with the settings (see Chapter 7.2). The positioner can be operated immediately after the electrical power supply (mA control signal) has been connected.

7.1 First start-up

After the TROVIS 3730-3 Positioner is put into operation for the first time after shipment, the wizard starts automatically after the electrical power is connected. It assists users to set the display's reading direction and the menu language (English upon first start-up). The reading direction of the display depends on the mounting position (position of the rotary pushbutton, right or left of the display).

1. Turn : Determine the display's reading direction.
2. Press  twice: Confirm reading direction.
3. Turn : Select language.
4. Press  three times: Confirm language.

→ Afterwards, the display automatically changes to the start screen (see the 'Operation' chapter).

→ When **ESC** is selected in the wizard, you can navigate through the displays of the wizard 1/3 (mounting position), 2/3 (language) and 3/3 (exit wizard) by selecting forward (➤) and back (◀).

→ If no settings are entered within five minutes, the display returns to the start screen.

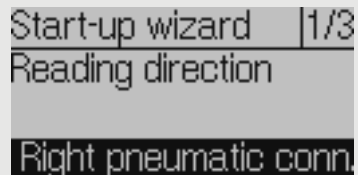







7.2 Start-up settings

→ Perform the start-up settings, keeping the following sequence:

Action	Chapter
1. Enable configuration	7.3
2. Select 'Start-up' menu	7.4
3. Set the actuator type	7.4.1
4. Determining the fail-safe position	7.4.2
5. Specify pin position	7.4.3
6. Setting the nominal range	7.4.4
7. Select initialization mode	7.4.5
8. Set initialization mode	7.4.6
9. Initialize the positioner	7.5



7.3 Enabling configuration to change parameters

1. Press  (in start screen) to change to the **main menu**.
 2. Turn  until **User level [6]** appears
(**On-site: read**) appears in this case when the enable configuration function is deactivated).
 3. Press and turn  until **On-site: write** appears.
 4. Press  to confirm.
 5. Keep  pressed down for two seconds to return to the start screen.
- Configuration is enabled. The write protection icon  is not displayed.

Note

Configuration is locked again if no settings are entered within 5 min.



7.4 Start-up menu

1. Press  (in start screen) to change to the **main menu**.
2. Turn  until **Start-up [7]** appears.
3. Press  to go to the **Start-up** menu.

7.4.1 Setting the actuator type

Three different parameters are available for selection:

- Linear actuator
- Rotary actuator
- Linear actuator (expert) with separate setting options for pin position and nominal range

1. Turn  (within **Start-up [7]** menu) until **Actuator [7.1]** appears.
2. Press and turn  to set the actuator type.
3. Press  to confirm the setting.

7.4.2 Determining the fail-safe position

Define the fail-safe position of the valve taking the valve type and the actuator's direction of action into account. Position the AIR TO OPEN/AIR TO CLOSE slide switch accordingly:

Fail-safe position	Description
Switch setting: AIR TO OPEN	Signal pressure opens the valve, e.g. for a fail-close valve
Switch setting: AIR TO CLOSE	Signal pressure closes the valve, e.g. for a fail-open valve



The switch position does not become effective until after initialization has been completed.

For checking purposes: after initialization is completed, the positioner display must read 0 % when the valve is closed. If this is not the case, change the slide switch position and re-initialize the positioner.

7.4.3 Specifying the pin position

The setting options depend on the entered actuator type:

- For linear actuator: **Pin position [7.5]** 'None', 17, 25, 35, 50, 70, 100, 200 or 300 mm
- For rotary actuator: **Pin position [7.6]**: 90°
- For linear actuator (expert): **Pin position [7.7]**: 10 to 655 mm



1. Turn  (within **Start-up [7]** menu) until **Pin position [7.5/7.6/7.7]** appears.
2. Press and turn  to enter the pin position to match how the actuator is mounted.
3. Press  to confirm the setting.

Note

A pin position needs to be entered for the **NOM** and **SUB** initialization modes (see Chapter 7.4.6).

7.4.4 Setting the nominal range

The possible adjustment range depends on the entered pin position.

1. Turn  (within **Start-up [7]** menu) until **Nominal range [7.10/7.11/7.12]** appears.
2. Press and turn  to set the nominal range.
3. Press  to confirm the setting.

Note

If no pin position has been entered, **Nominal range** is only available for the **Linear actuator (expert)** actuator type.

7.4.5 Selecting the initialization mode

During initialization, the positioner adapts itself optimally to the friction conditions and the signal pressure required by the control valve. The type and extent of autotuning depends on the initialization mode selected. The following initialization modes are available:

MAX: Maximum range

The positioner determines travel/angle of rotation of the closing member from the CLOSED position to the opposite travel stop and adopts this travel/angle of rotation as the operating range from 0 to 100 %.

NOM: Nominal range · Initialization mode for all globe valves

The calibrated sensor allows the exact valve travel to be measured very accurately. During initialization, the positioner checks whether the control valve can move through the indicated nominal range (travel or angle) without collision. If this is the case, the indicated nominal range is adopted as the operating range.

MAN: Manually selected end positions · Initialization mode for globe valves

Before starting initialization, move the control valve manually to the end positions. The positioner calculates the travel/angle difference from the two positions that the valve moved to and adopts it as the operating range. This initialization mode can only be started when the valve position differs in the end positions and the positioner has not yet been initialized.

SUB: Substitute calibration · To replace a positioner while the plant is running

A complete initialization procedure takes several minutes and requires the valve to move through its entire travel range several times. In the SUB initialization mode, the control parameters are estimated and not determined by an initialization procedure. As a result, a high level of accuracy cannot be expected. A different initialization mode should be selected if the plant allows it.

The substitute calibration is used to replace a positioner while the process is running. For this purpose, the control valve is usually blocked mechanically in a certain position or pneumatically by means of a pressure signal which is routed to the actuator externally. The blocking position ensures that the plant continues to operate with this valve position. The blocking position can also be the fail-safe position when this condition is beneficial for the temporary phase.



Perform a reset before re-initializing the positioner if the substitute positioner has already been initialized (see the 'Operation' chapter).

7.4.6 Setting the initialization mode

i Note

Configuration is locked again if no settings are entered within 5 min. Enable configuration: see 7.3.

Setting the **MAX** and **NOM** initialization modes:

1. Turn  (within **Start-up [7]** menu) until **Initialization mode [7.24]** appears.
2. Press and turn  to set the **MAX** or **NOM** initialization mode.
3. Press  to confirm the setting.







i Note

A pin position needs to be entered for the **NOM** initialization mode (see 7.4.3).







Setting the **MAN** initialization mode

i Note

The **MAN** initialization mode can only be started when the valve position differs in the end positions and the positioner has not yet been initialized.

1. Turn  (within **Start-up [7]** menu) until **Initialization mode [7.24]** appears.
2. Press and turn  to set the **MAN** initialization mode.
3. Press  to confirm the setting.
4. Turn  until **Set point (open-loop control) [7.28]** appears.
5. Press and turn  to move the valve to the first end position. Enter a value from -34.0 to $+34.0^\circ$.
6. Press  to confirm the value (first end position).







Start-up and configuration







7. Turn  until **Adopt valve position 1 [7.29]** appears.
8. Press  to confirm the entered first valve position as valve position 1.
9. Turn  until **Set point (open-loop control) [7.28]** appears.
10. Press and turn  to move the valve to the second end position. Enter a value from -34.0 to $+34.0^\circ$.
11. Press  to confirm the value (second end position).
12. Turn  until **Adopt valve position 2 [7.31]** appears.
13. Press  to confirm the entered second valve position as valve position 2.

Setting the *SUB* initialization mode

Note

The **SUB** initialization mode is a substitute calibration, which can be selected to replace a positioner while the process is running. In this mode, the control parameters are estimated and not determined by an initialization procedure. As a result, a high level of accuracy cannot be expected. A different initialization mode should be selected if the plant allows it. The **SUB** initialization mode can only be started when the positioner has not yet been initialized.

1. Write down the current valve position in %.
2. Turn  (within **Start-up [7]** menu) until **Initialization mode [7.24]** appears.
3. Press and turn  to set the **SUB** initialization mode.
4. Press  to confirm the setting.
5. Turn  until **Pin position [7.5/7.6/7.7]** appears.
6. Press and turn  to enter the pin position to match how the actuator is mounted.
7. Press  to confirm the setting.

8. Turn  until **Nominal range** [7.10/7.11/7.12] appears.
9. Press and turn  to set the actuator's nominal range.
10. Press  to confirm the setting.
11. Turn  until **Current valve position** [7.35] appears.
12. Press and turn  to set the current valve position in % (see step 1), at which the valve is currently blocked.
13. Turn  until **Direction of rotation** [7.36] appears.
14. Press and turn  to set the direction of rotation so that the lever's direction of rotation matches the valve's closing direction.

Example:

The valve closes when the plug stem moves downward. This action causes the positioner's lever to turn counterclockwise (when looking at the display).

→ Setting: Counterclockwise

i Note

After performing the SUB initialization, the control parameters can be changed (**Configuration** [8]/**Control parameters** [8.7], see Appendix A).

7.5 Initializing the positioner

→ For positioners with optional limit switches, read Chapter 7.6 before initializing the positioner.

Once all settings have been made according to Chapter 7.4, the positioner initialization can be started.

WARNING

Risk of injury by exposed moving parts on the positioner, actuator or valve.

→ Do not touch or block exposed moving parts.



NOTICE

The process is disturbed by the movement of the actuator or valve.

→ Do not perform the initialization while the process is running. First isolate the plant by closing the shut-off valves.

Note

The initialization can only be started over the menu after configuration has been enabled.

1. Turn  (within **Start-up [7] menu**) until **Start initialization [7.75]** appears.
2. Press  to start initialization.
3. Confirm warning with OK.
4. Wait until the initialization process is completed.

After initialization, the positioner remains in the **Start initialization [7.75]** menu item.

→ Keep  pressed down for two seconds to return to the **main menu**.

→ Keep  pressed down again for two seconds to return to the start screen.

→ **The positioner is ready for use.**

Tip

Initialization can also be started by pressing the initialization key (INIT). See the 'Operation' chapter.

7.6 Adjusting the switching points

The switching points of the limit switches are usually adjusted so that a signal is issued in the travel/angle end positions. Optionally, the switching point can also be adjusted to any position within the travel/angle range, e.g. if an intermediate position is to be indicated.

Both switching points are adjusted at two adjustment screws on the top of the rotary knob:

- Limit switch 1: adjustment screw 1
- Limit switch 2: adjustment screw 2

The adjustment screws are marked: **I** for adjustment screw 1 and **II** for adjustment screw 2.

The following applies to all adjustments:

- Always move the valve to the switching point from the mid-position (50 %) on adjusting or checking the switching point.
- To guarantee the switching under all ambient conditions, adjust the switching point approx. 5 % before the mechanical stop (OPEN/CLOSED).
- Contact functions:
 - Tag leaving the field: contact is closed
 - Tag entering the field: contact is opened

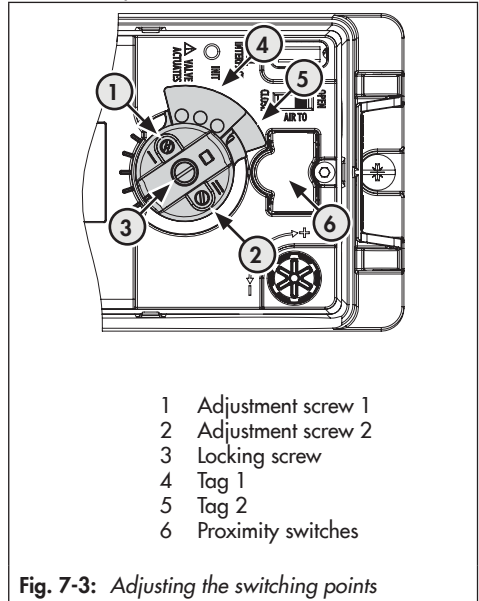

Fig. 7-3: Adjusting the switching points

7.6.1 Adjusting switching position 1 (e.g. closed valve)

1. Initialize the positioner (see Chapter 7.5).
2. Move the valve using the manual mode (see the 'Operation' chapter) to 5 % (read the value off the display).
3. Undo the locking screw (3).
4. Turn the adjustment screws to adjust the tags until they leave or enter the field causing the switching amplifier to respond. You can measure the switching voltage for checking purposes.
5. Keep hold of the rotary knob and tighten the locking screw (3) (tightening torque 1.1 ± 0.1 Nm).
6. Move the valve away from the switching position and check whether the output signal changes.
7. Move the valve back to the switching position and check the switching point.

7.6.2 Adjusting switching position 2 (e.g. open valve)

1. Initialize the positioner (see Chapter 7.5).
2. Move the valve using the manual mode (see the 'Operation' chapter) to 95 % (read the value off the display).
3. Undo the locking screw (3).
4. Turn the adjustment screws to adjust the tags until they leave or enter the field causing the switching amplifier to respond. You can measure the switching voltage for checking purposes.
5. Keep hold of the rotary knob and tighten the locking screw (3) (tightening torque 1.1 ± 0.1 Nm).
6. Move the valve away from the switching position and check whether the output signal changes.
7. Move the valve back to the switching position and check the switching point.

8 Operation

The work described in this chapter is to be performed only by personnel appropriately qualified to carry out such tasks.

⚠ DANGER

Risk of fatal injury due to the ignition of an explosive atmosphere.

- Observe EN 60079-14 (VDE 0165, Part 1) for work on the positioner in potentially explosive atmospheres.
- Work in potentially explosive atmospheres is to be performed only by personnel who has undergone special training or instructions or who is authorized to work on explosion-protected devices in hazardous areas.



⚠ WARNING

Crush hazard arising from moving parts on the valve.

- Do not touch any moving valve parts while the control valve is in operation.
- Before performing any mounting or installation work on the positioner, put the control valve out of operation by disconnecting and locking the supply air and control signal.
- Do not impede the movement of the actuator and plug stem by inserting objects into the yoke.

8.1 Changing the reading direction of the display

The reading direction of the display can be adapted to the mounting situation (turned 180°) at any time.

1. Press  (in start screen) to change to the **main menu**.
2. Turn  until **Change reading direction [5]** appears.
3. Press  to change reading direction.

8.2 HART® communication

Conditions for HART® communication:

- Supply the positioner with at least 3.6 mA.
- Connect the FSK modem in parallel to the current loop.

A DTM file (Device Type Manager) conforming to the Specification 1.2 is available for communication. This allows the device, for example to be run with the PACTware user interface. All the positioner's parameters are accessible over the DTM and the user interface.

- For start-up, first proceed as described in the 'Start-up and configuration' chapter.

i Note

*If complex functions are started in the positioner, which require a long calculation time or lead to a large quantity of data being saved in the volatile memory of the positioner, the alert 'busy' is issued by the DTM file. This alert is **not an error message** and can be simply confirmed.*

Locking HART® communication

The write access for HART® communication can be locked. This function can be enabled or disabled locally at the positioner (**Configuration [8]/HART communication [8.20]/Locked [8.20.1]**) (setting options: Yes/No, default setting: No, see parameter list in Appendix A).

Locking on-site operation

The on-site operation can be locked over HART® communication. This locking function can only be disabled over HART® communication. On-site operation is enabled by default.

i Note

The access over TROVIS-VIEW is also locked through the locking of on-site operation over HART® communication.

8.2.1 Dynamic HART® variables

The HART® specification defines four dynamic variables consisting of a value and an engineering unit. These variables can be assigned to device parameters as required. The universal HART® command 3 reads the dynamic variables out of the device. This allows manufacturer-specific parameters to also be transferred using a universal command.

In the TROVIS 3730-3 Positioner, the dynamic variables can be assigned as follows in the Configuration folder (> HART communication):

Table 8-1: *Dynamic HART® variables assignment*

Variable	Unit, description
Set point at the input	%
Valve position	%
Set point deviation	%
Condensed state	Current state active/not active 0 No message 1 Maintenance required 3 Failure 4 Out of specification 7 Function check 255 Highest classification
Option A: binary input	Binary input active ¹⁾ 0 No 1 Yes
Option B: binary input	Binary input active ¹⁾ 0 No 1 Yes
Total valve travel	Current total valve travel
Current temperature	Reading of current temperature
Results of PST	Not executed/successful/test-specific error message ³⁾
Results of FST	Not executed/successful/test-specific error message ³⁾
Discrete valve position	Positioner not initialized, Closed, Open, Intermediate position
Supply pressure	bar ²⁾
OUTPUT 138 pressure	Signal pressure in bar ²⁾

¹⁾ Parameter assessment depends on the optional equipment used in the positioner

²⁾ Analysis of the parameter only possible when the positioner is fitted with the optional pressure sensors.

³⁾ See Table 8-2

Operation



Table 8-2: *Meaning of readings for 'Results of PST' and 'Results of FST'*

Reading	Description
0	Not executed
1	Successful
2	Canceled (man.)
3	Start criteria
4	Timeout
5	Internal error
6	Brownout
7	IP shutdown
8	Forced venting
9	Canceled: current
10	Function active
11, 1801	Canceled: timeout
255	Unknown
1000, 2017, 3008	Incorrect operating mode
1050, 1053, 1070, 1080, 1090, 1110, 1170, 1180, 1183, 1271, 1310, 1800	Canceled: internal error
1051, 1071, 1081, 1091, 1111, 1112, 1132, 1141, 1151, 1156, 1161, 1166, 1171, 1181, 1311, 1801	Canceled: timeout
1052, 1167	Canceled: no movement possible
1054, 1082, 1093	Canceled: angle limitation
1092, 1182, 1324, 3001	Canceled: travel too small
1094	Canceled: rated travel not reached
1113, 1114, 1130, 1131, 1140, 1150, 1153, 1154, 1155, 1160, 1165, 1250, 1260, 1270, 1280, 1281, 1327	Canceled: control accuracy
1133, 1142, 1152, 1157, 1272	Low control accuracy
1184, 1185, 1186	Angle limitation
1320, 1900	Canceled: pneumatic module not initialized
1321, 1901	Zero calibration active
1322, 1902	Initialization in progress
1323	Canceled: pin position
1325	Positioner is initialized
1326	No MAN positions entered
1400, 1401, 1405	Canceled: travel
1402, 1403, 1404	Canceled: pneumatics (exhaust position outside range)
1410, 1420, 1421, 1422	Canceled: control parameters not tuned correctly
1802, 3000	Canceled: low supply pressure

Reading	Description
1803	Canceled: zero shift
1903	Canceled: positioner not initialized
2000	Canceled: x monitoring
2001	Canceled: timeout (dead time)
2002	Canceled: timeout (test time)
2003	Canceled: set point changed
2004	Canceled: timeout (start position not reached)
2005	Canceled: timeout (no movement at test start)
2006	Canceled: timeout (end position not reached)
2007	Canceled: timeout (no movement to original start position)
2008	Canceled: timeout (original start position not reached)
2009	Canceled by user (communication)
2010	Canceled: tolerance band exited
2011	Canceled: remaining test time insufficient
2012	Canceled: valve hunting
2013	Canceled by fail-safe position
2014	Canceled: pressure limit violated
2015	Start crit.: fixed value active
2016	Start crit.: test analysis in progress
2018	Start crit.: fixed value active
2019	Start crit.: supply press. too low
2020	Diagram not saved
2021	Start crit.: press. limit violated
2022	Canceled: fixed value active
2023	Dead band could not be measured
2024	Test not started. Max. no. of write-protect. reports reached
2025	Canceled: hardware fault
3002	Canceled: end position (supply) not reached
3003	Canceled: end position (exhaust) not reached
3004	Canceled: pressure sensors do not exist
3005	Canceled: pressure value invalid
3006	Valve signature failed
3007	Canceled: double-acting actuator
3009	Cannot be run after SUB initialization
4000	Measurement of movement canceled

8.3 Changing operating mode

After initialization has been completed successfully, the positioner is in automatic mode (**AUTO**). Switchover from automatic to manual mode (**MAN**) is bumpless.

1. Press  (in start screen) to change to the **main menu** (**Target mode** menu is displayed).
2. Press  again. Turn to set the target mode (**AUTO/SAFE/MAN**).
3. Press  to confirm.

8.4 Performing zero calibration

WARNING

Risk of personal injury due to moving parts on the valve.

- *During zero calibration, do not insert hands or fingers into the valve yoke and do not touch any moving valve parts.*
- *Do not block the actuator stem.*

In case of inconsistencies in the closed position of the valve, e.g. with soft-seated plugs, it might be necessary to recalibrate zero. During zero calibration, the valve moves once to the closed position.

WARNING

Risk of injury by exposed moving parts on the positioner, actuator or valve.

- *Do not touch or block exposed moving parts.*



NOTICE

The process is disturbed by the movement of the actuator or valve.

- *Do not perform the zero calibration while the process is running. First isolate the plant by closing the shut-off valves.*

Note

A zero calibration is not possible if there is zero point shift of more than 5 %.

1. Turn  (within **Start-up [7]** menu) until **Start zero calibration [7.76]** appears.
2. Press  to start zero calibration.
3. Confirm warning with OK.
4. Wait until zero calibration is completed.

After zero calibration, the positioner remains in the **Start zero calibration [7.76]** menu item.

→ Keep  pressed down for two seconds to return to the **main menu**.

→ Keep  pressed down again for two seconds to return to the start screen.

8.5 Resetting the positioner

NOTICE

The process is disturbed by the movement of the actuator stem.

→ Do not reset the positioner while the process is running. First isolate the plant by closing the shut-off valves.

A reset allows the positioner to be reset to the default settings. The TROVIS 3730-3 Positioner has the reset options listed in Table 8-3.

The behavior of the menu items varies depending on the selected reset function (see Appendix A (configuration instructions)).





1. Turn  (within **main menu**) until **Reset functions [14]** appears.
2. Press  to go to the menu.
3. Turn  to select a reset function.
4. Press  to perform the reset function.
5. Confirm warning with OK.
6. Wait until the reset function is completed.

Table 8-3: Reset function

Reset function	Description	Sample application
Reset diagnosis	Resets all diagnostic functions including graphs and histograms.	Diagnosis analyses of operating hours in the past are no longer relevant.
Reset (standard)	Resets the positioner to the state as upon delivery. Settings in Identification parameters (8.2 menu item) remain unchanged. Configuration settings of the diagnostics are reset.	The attachment situation has changed. The valve has been repaired or modified. The positioner diagnosis data are no longer relevant. The positioner must be re-initialized.
Reset (advanced)	All parameters will be reset to their defaults adjusted upon delivery.	Positioner is mounted on another actuator/valve.
Restart	The positioner is shut down and restarted.	
Reset initialization	All parameters for the start-up settings are reset. The positioner needs to be re-initialized afterwards.	Changes to the start-up settings are necessary.

9 Malfunctions

! DANGER

Risk of fatal injury due to the ignition of an explosive atmosphere.

- Observe EN 60079-14 (VDE 0165, Part 1) for work on the positioner in potentially explosive atmospheres.
- Work in potentially explosive atmospheres is to be performed only by personnel who has undergone special training or instructions or who is authorized to work on explosion-protected devices in hazardous areas.

! DANGER

Risk of bursting in the pneumatic actuator due to the use of a fail-in-place module.

Before working on the positioner, actuator or any other valve accessories:

- Depressurize all plant sections concerned and the actuator. Release any stored energy.

! WARNING

Crush hazard arising from actuator and plug stem moving.

- Do not insert hands or finger into the yoke while the air supply is connected to the positioner.
- Before working on the positioner, disconnect and lock the pneumatic air supply.
- Do not impede the movement of the actuator and plug stem by inserting objects into the yoke.

! WARNING

Sudden loud noise when the pneumatic actuator vents.

- Wear hearing protection when working near the valve.

Malfunctions and errors are indicated on the display by error messages in conjunction with an icon for status classification (see Table 9-1) and an error ID. Table 9-2 lists possible error messages and recommended action.

i Note

Contact SAMSON's After-sales Service for malfunctions not listed in the table. The status classification of error messages can be changed in SAMSON's TROVIS-VIEW software.

Table 9-1: Icon showing status classification





















































Icon	Meaning
	Failure
	Function check
	Out of specification
	Maintenance demanded
	No message









Table 9-2: *Troubleshooting*

Error ID	Status	Message	Recommended action/description
1		Init: rated travel not achieved	→ Check positioner attachment, pin position and supply pressure.
2		Init: travel too small	→ Compare adjusted rated travel with the valve travel. → Check positioner attachment, pin position and supply pressure.
3		Init: no movement	→ Check positioner mounting, pin position and supply air. Check piping and configuration of the mounting parts. Move the positioner out of the fail-safe position.
21		Init: pin position	→ Check pin position.
26		Timeout for detection of zero	→ Zero calibration took too long. Check supply pressure and positioner attachment.
27		Positioner not initialized	→ Perform an initialization.
29		Fail-safe position mode	→ Change operating mode if no error exists.
32		Init: canceled externally	→ Check power supply/electrical signal.
36		Zero shift too large	→ The difference to the previous zero point is too large. Check the supply pressure and positioner attachment.
50		PST: start criteria not met	→ Check the positioner configuration.
51		PST: cancellation criteria met	→ Positioner configuration. Check valve and positioner attachment.
56		FST: start criteria not met	→ Check the positioner configuration.
57		FST: cancellation criteria met	→ Positioner configuration. Check valve and positioner attachment.
144		Temperature inside device below min. limit	→ Check the ambient temperature.

Error ID	Status	Message	Recommended action/description
145		Temperature inside device above max. limit	→ Check the ambient temperature.
146		Test in progress	The positioner is in the test mode (e.g. initialization process, step response test etc.). → Wait until the test is completed or cancel it.
148		IP shutdown	→ Check power supply/electrical signal.
149		Brownout	→ Check power supply/electrical signal.
150		Operating mode not AUTO	The positioner is in an operating mode other than AUTO. No error exists.
153		Current too low	→ Check power supply/electrical signal.
154		Current too high	→ Check power supply/electrical signal.
155		Dynamic stress factor exhausted.	→ We advise ordering the spare part soon.
156		Limit for total valve travel exceeded	→ Check the control valve to ensure it functions properly.
157		Forced venting function	→ Check supply voltage. Search for the reason why the forced venting was triggered.
160		Binary input option A active	→ Reading matches the configuration of optional additional function.
161		Binary input option B active	→ Reading matches the configuration of optional additional function.
162		Combination of options invalid	→ Remove or exchange option, if necessary.
194		Set point deviation	→ Check positioner attachment and supply pressure.
195		Lower end position shifted	→ Check seat and plug.
196		Upper end position shifted	→ Check seat and plug.
198		AMR signal outside range	→ Check positioner attachment. An external malfunction or a hardware error may possibly exist.

Malfunctions

Error ID	Status	Message	Recommended action/description
201		Switch position for forced venting function incorrect	→ Set correct switch position.
206		Valve signature failed	→ Check configuration.
207		No supply pressure	→ Check the supply pressure.
208		Low supply pressure	→ Check the supply pressure.
209		Pressure sensors failed	→ Check the supply pressure. → Check power supply/electrical signal.
210		Supply pressure > 7 bar	→ Check the supply pressure.
211		Emergency mode active	→ Check travel measurement.
212		Friction change (mid-position)	The friction conditions have changed. → Check the positioner's mechanical functions and set-up.
213		Friction change (open pos.)	
214		Friction change (closed pos.)	
215		Logging suspended	→ Briefly, the data volume was too high to process.
221		External position sensor error	→ Check sensor and sensor lead for possible defects.
222		Working range in closed position	→ Check positioner attachment and valve. The working range may have shifted and is close to the end position.
223		Working range in max. OPEN position	→ Check positioner attachment and valve. The working range may have shifted and is close to the end position.
224		Shifting working range: operating range is shifting towards the minimum OPEN position	→ Check positioner attachment and valve. The operating range may have shifted.
225		Shifting working range: operating range is shifting towards the maximum OPEN position	→ Check positioner attachment and valve. The operating range may have shifted.
226		Limited working range: lower range	→ Check supply pressure, positioner attachment and valve. There may be leakage or a blockage.

Error ID	Status	Message	Recommended action/description
227		Limited working range: upper range	→ Check supply pressure, positioner attachment and valve. There may be leakage or a blockage.
237		Spring rupture possibly detected	→ Check actuator springs.
238		Broken spring detected	→ Check actuator springs.
239		Pneumatic leakage	→ Check supply pressure, positioner attachment and valve.
2641		Init: canceled (control accuracy)	→ Check positioner attachment, pin position and supply air. Re-initialize the positioner. Possibly use a screw restriction.
2644		Init: low control accuracy	→ Check positioner attachment, pin position and supply air. Re-initialize the positioner. Possibly use a screw restriction.
2643		Init: angle limitation	→ Check positioner attachment, lever and pin position.
2645		Init.: timeout	→ Check positioner mounting, pin position and supply air. Check piping and configuration of the mounting parts.

Further troubleshooting

Error description	Action
No reading on the display	<ul style="list-style-type: none"> → Check electrical connection and power supply. → Check the ambient temperature (the display's operating range is from -30 to +65 °C).
Actuator moves too slowly	<ul style="list-style-type: none"> → Check the supply pressure. → Correct setting for filter (transit time). → Check the cross-section of the piping and screw fittings. → Check the configuration of the mounting parts.

Malfunctions

Actuator moves in the wrong direction.	<ul style="list-style-type: none">→ Check the characteristic setting.→ Check piping.→ Check the configuration of the mounting parts.
Air leaks from the positioner.	<ul style="list-style-type: none">→ Check seals.
Limit switch does not work properly	<ul style="list-style-type: none">→ Check the mounting and cabling.→ Check polarity of signal wires.

9.1 Emergency action

Upon failure of the air supply and/or electrical signal, the positioner vents the actuator, causing the valve to move to the fail-safe position determined by the actuator. Plant operators are responsible for emergency action to be taken in the plant.

**Tip**

Emergency action in the event of valve failure is described in the associated valve documentation.

10 Servicing

The work described in this chapter is to be performed only by personnel appropriately qualified to carry out such tasks.

⚠ DANGER

Risk of fatal injury due to the ignition of an explosive atmosphere.

- Observe EN 60079-14 (VDE 0165, Part 1) for work on the positioner in potentially explosive atmospheres.
- Work in potentially explosive atmospheres is to be performed only by personnel who has undergone special training or instructions or who is authorized to work on explosion-protected devices in hazardous areas.

⚠ WARNING

Crush hazard arising from actuator and plug stem moving.

- Do not insert hands or finger into the yoke while the air supply is connected to the positioner.
- Before working on the positioner, disconnect and lock the pneumatic air supply.
- Do not impede the movement of the actuator and plug stem by inserting objects into the yoke.

⚠ WARNING

Intrinsic safety rendered ineffective in intrinsically safe devices.

- Only connect intrinsically safe devices intended for use in intrinsically safe circuits

to certified intrinsically safe input-connected units.

- Do not place intrinsically safe devices back into operation that were connected to intrinsically safe input-connected units without certification.
- Do not exceed the maximum permissible electric values specified in the EU type examination certificates when interconnecting intrinsically safe electrical equipment (U_i or U_o , I_i or I_o , P_i or P_o , C_i or C_o and L_i or L_o).

⚠ WARNING

Sudden loud noise when the pneumatic actuator vents.

- Wear hearing protection when working near the valve.

The positioner was checked by SAMSON before it left the factory.

- The product warranty becomes void if service or repair work not described in these instructions is performed without prior agreement by SAMSON's After-sales Service.
- Only use original spare parts by SAMSON, which comply with the original specifications.

10.1 Cleaning the cover window

The window is made of Makrolon® and will be damaged when cleaned with abrasive cleaning agents or agents containing solvents. To avoid damage:

Servicing

- Do not rub the window dry.
- Do not use any cleaning agents containing chlorine or alcohol or abrasive cleaning agents.
- Use a non-abrasive, soft cloth for cleaning.

10.2 Firmware updates

Contact your local SAMSON sales site (▶ www.samsongroup.com > About SAMSON > Sales sites) to request a firmware update.

Required specifications





Please submit the following details on requesting a firmware update (see the 'Markings on the device' chapter):

- Device type: TROVIS 3730-3
- Serial number
- Material number
- Current software version
- Required software version

10.3 Periodic inspection and testing of the positioner

SAMSON recommends inspection and testing according to Table 10-1 at the minimum.

Table 10-1: *Recommended inspection and testing*

Inspection and testing	Action to be taken in the event of a negative result
Check the markings, labels and nameplates on the positioner for their readability and completeness.	Contact SAMSON when nameplates or labels are damaged, missing or incorrect to renew them.
	Clean any inscriptions that are covered with dirt and are illegible.
Check the positioner to ensure that it is mounted firmly.	Tighten the any loose mounting screws.
Check the pneumatic connections.	Tighten any loose male connectors of the screw fittings.
	Renew any air pipes or hoses that leak.
Check the power supply wires.	Tighten any loose cable glands.
	Make sure that the stranded wires are pushed into the terminals and tighten any loose screws on the the terminals.
	Renew damaged lines.
Check error messages on the display (indicated by the  ,  ,  and  icons).	Troubleshooting (see the 'Malfunctions' chapter).

11 Decommissioning

The work described in this chapter is to be performed only by personnel appropriately qualified to carry out such tasks.

⚠ DANGER

Risk of fatal injury due to the ignition of an explosive atmosphere.

- *Observe EN 60079-14 (VDE 0165, Part 1) for work on the positioner in potentially explosive atmospheres.*
 - *Work in potentially explosive atmospheres is to be performed only by personnel who has undergone special training or instructions or who is authorized to work on explosion-protected devices in hazardous areas.*
-

⚠ WARNING

Sudden loud noise when the pneumatic actuator vents.

- *Wear hearing protection when working near the valve.*
-

ⓘ NOTICE

The process is disturbed by interrupting closed-loop control.

- *Do not mount or service the positioner while the process is running and only after isolating the plant by closing the shut-off valves.*
-

To decommission the positioner, proceed as follows:

1. Disconnect and lock the air supply and signal pressure.
2. Open the positioner cover and disconnect the wires for the control signal.

12 Removal

The work described in this chapter is to be performed only by personnel appropriately qualified to carry out such tasks.

⚠ DANGER

Risk of fatal injury due to the ignition of an explosive atmosphere.

- *Observe EN 60079-14 (VDE 0165, Part 1) for work on the positioner in potentially explosive atmospheres.*
 - *Work in potentially explosive atmospheres is to be performed only by personnel who has undergone special training or instructions or who is authorized to work on explosion-protected devices in hazardous areas.*
-

1. Put the positioner out of operation (see the 'Decommissioning' chapter).
2. Disconnect the wires for the control signal from the positioner.
3. Disconnect the lines for supply air and signal pressure (not required for direct attachment using a connection block).
4. To remove the positioner, loosen the two fastening screws on the positioner.

13 Repairs

A defective positioner must be repaired or replaced.

! NOTICE

Risk of positioner damage due to incorrect service or repair work.

- Do not perform any repair work on your own.
- Contact SAMSON's After-sales Service for service and repair work.

13.1 Servicing explosion-protected devices

If a part of the device on which the explosion protection is based needs to be serviced, the device must not be put back into operation until a qualified inspector has assessed it according to explosion protection requirements, has issued an inspection certificate, or given the device a mark of conformity. Inspection by a qualified inspector is not required if the manufacturer performs a routine test on the device before putting it back into operation and the passing of the routine test is documented by attaching a mark of conformity to the device. Replace explosion-protected components only with original, routine-tested components by the manufacturer.

Devices that have already been operated outside hazardous areas and are intended for future use inside hazardous areas must comply with the safety requirements placed on serviced devices. Before being operated

inside hazardous areas, test the devices according to the specifications for servicing explosion-protected devices.

13.2 Returning devices to SAMSON

Defective positioners can be returned to SAMSON for repair.

Proceed as follows to return devices to SAMSON:

1. Put the positioner out of operation (see the 'Decommissioning' chapter).
2. Remove the positioner (see the 'Removal' chapter).
3. Proceed as described on the Returning goods page of our website
 ► www.samsongroup.com > Service > After-sales Service > Returning goods

14 Disposal



SAMSON is a producer registered in Europe, agency in charge ► www.samsongroup.com > About SAMSON > Environment, Social & Governance > Material Compliance > Waste electrical and electronic equipment (WEEE).
WEEE reg. no.: DE 62194439

Information on substances listed as substances of very high concern (SVHC) on the candidate list of the REACH regulation can be found in the document "Additional Information on Your Inquiry/Order", which is added to the order documents, if applicable. This document includes the SCIP number assigned to the devices concerned. This number can be entered into the database on the European Chemicals Agency (ECHA) website (► <https://www.echa.europa.eu/scip-database>) to find out more information on the SVHC contained in the device.

- Observe local, national and international refuse regulations.
- Do not dispose of components, lubricants and hazardous substances together with your other household waste.



Tip

On request, SAMSON can appoint a service provider to dismantle and recycle the product.

15 Certificates

The following certificates are included on the next pages:

- EU declaration of conformity for TROVIS 3730-3
- EU declaration of conformity for TROVIS 3730-3-110, -510, -810
- EU type examination certificate for TROVIS 3730-3-110, -510, -810
- ATEX/IECEX certificate for TROVIS 3730-3
- FM approvals

The certificates shown were up to date at the time of publishing. The latest certificates can be found on our website:

▶ www.samsongroup.com > Products > Valve accessories > TROVIS 3730-3



EU Konformitätserklärung / EU Declaration of Conformity / Déclaration UE de conformité

Die alleinige Verantwortung für die Ausstellung dieser Konformitätserklärung trägt der Hersteller/
This declaration of conformity is issued under the sole responsibility of the manufacturer/
La présente déclaration de conformité est établie sous la seule responsabilité du fabricant.
Für das folgende Produkt / For the following product / Nous certifions que le produit

Elektropneumatischer Stellungsregler mit HART Kommunikation / Electropneumatic Positioner with HART communication / Positionneur électropneumatique avec communication HART TROVIS 3730-3-...

wird die Konformität mit den einschlägigen Harmonisierungsrechtsvorschriften der Union bestätigt/
the conformity with the relevant Union harmonisation legislation is declared with/
est conforme à la législation d'harmonisation de l'Union applicable selon les normes:

EMC 2014/30/EU	EN 61000-6-2:2005, EN 61000-6-3:2007 +A1:2011, EN 61326-1:2013
RoHS 2011/65/EU	EN 50581:2012

Hersteller / Manufacturer / Fabricant:

SAMSON AKTIENGESELLSCHAFT
Weismüllerstraße 3
D-60314 Frankfurt am Main
Deutschland/Germany/Allemagne

Frankfurt / Francfort, 2018-11-21

Im Namen des Herstellers/ On behalf of the Manufacturer/ Au nom du fabricant.

Dr. Julian Fuchs
Zentralabteilungsleiter/Head of Department/Chef du département
Entwicklung Ventilanbaugeräte und Messtechnik
Development Valve Attachments and Measurement Technologies

Dipl.-Ing. Silke Bianca Schäfer
Total Quality Management/
Management par la qualité totale



EU Konformitätserklärung / EU Declaration of Conformity / Déclaration UE de conformité

Die alleinige Verantwortung für die Ausstellung dieser Konformitätserklärung trägt der Hersteller/
This declaration of conformity is issued under the sole responsibility of the manufacturer/
La présente déclaration de conformité est établie sous la seule responsabilité du fabricant.
Für das folgende Produkt / For the following product / Nous certifions que le produit

Elektropneumatischer Stellungsregler mit HART Kommunikation / Electropneumatic Positioner with HART communication / Positionneur électropneumatique avec communication HART TROVIS 3730-3-110..., -510..., -810...

entsprechend der EU-Baumusterprüfbescheinigung BVS 18 ATEX E 044 X ausgestellt von der/
according to the EU Type Examination BVS 18 ATEX E 044 X issued by/
établi selon le certificat CE d'essais sur échantillons BVS 18 ATEX E 044 X émis par:

DEKRA EXAM GmbH
Dinnendahlstraße 9
D-44809 Bochum

Benannte Stelle/Notified Body/Organisme notifié 0158

wird die Konformität mit den einschlägigen Harmonisierungsrechtsvorschriften der Union bestätigt/
the conformity with the relevant Union harmonisation legislation is declared with/
est conforme à la législation d'harmonisation de l'Union applicable selon les normes:

EMC 2014/30/EU	EN 61000-6-2:2005, EN 61000-6-3:2007 +A1:2011, EN 61326-1:2013
Explosion Protection 2014/34/EU	EN 60079-0:2012+A11:2013, EN 60079-11:2012, EN 60079-15:2010, EN 60079-31:2014
RoHS 2011/65/EU	EN 50581:2012

Hersteller / Manufacturer / Fabricant:

SAMSON AKTIENGESELLSCHAFT
Weismüllerstraße 3
D-60314 Frankfurt am Main
Deutschland/Germany/Allemagne

Frankfurt / Francfort, 2018-11-22

Im Namen des Herstellers/ On behalf of the Manufacturer/ Au nom du fabricant.

Dr. Julian Fuchs
Zentralabteilungsleiter/Head of Department/Chef du département
Entwicklung Ventilanbaugeräte und Messtechnik
Development Valve Attachments and Measurement Technologies

Dipl.-Ing. Silke Bianca Schäfer
Total Quality Management/
Management par la qualité totale

Installation Manual for Apparatus certified by FM Approvals for use in Hazardous Classified Locations

Electrical rating of Intrinsically Safe / Non-Incendive Apparatus for installation in Hazardous Locations

Table 1: Maximum values

Circuit	Signal Circuit	Position Transmitter	Limit Switches Inductive	Limit Switches Software
Circuit No.	1	2	3 and 4	5 and 6
Terminal No.	+11 / -12	+31 / -32	+41 / -42 and +51 / -52	+45 / -46 and +55 / -56
V _{max} or U _i	28 V	28 V	16 V	16 V
I _{max} or I _i	115 mA	115 mA	25 mA or 52 mA	52 mA
P _i	1 W	1 W	64 mW or 169 mW	169 mW
C _i	16.3 nF	11.1 nF	71.1 nF	12.2 nF
L _i	negligible	negligible	100 µH	negligible
Rated values	I _N = 4 mA...20 mA	U _N = 24 V DC	* U _N = 8.2 V R _i = 1 kΩ	* U _N = 8.2 V R _i = 1 kΩ
Circuit	External Position Sensor	Forced Venting	Binary Output (NAMUR)	Binary Input (24 V DC)
Circuit No.	7	8	9	10
Terminal No.	V_REF / PISTE / GND	+81 / -82	+83 / -84	+87 / -88
V _{max} or U _i	4.8 V	28 V	16 V	28 V
I _{max} or I _i	64 mA	115 mA	52 mA	115 mA
P _i	74 mW	1 W	169 mW	1 W
C _i		11.1 nF	12.2 nF	11.1 nF
L _i		negligible	negligible	negligible
Rated values		U _N = 24 V DC	* U _N = 8.2 V R _i = 1 kΩ	U _N = 24 V DC

* For connection to NAMUR switching amplifier acc. to IEC 60947-5-6

Note: Entity / Nonincendive Field Wiring Parameters must meet the following requirements:

$$U_0 \text{ or } V_{oc} \leq U_i \text{ or } V_{max} / I_0 \text{ or } I_{sc} \leq I_i \text{ or } I_{max} / P_0 \leq P_i \text{ or } P_{max}$$

$$C_a \text{ or } C_o \geq C_i + C_{cable} / L_a \text{ or } L_o \geq L_i + L_{cable}$$

The correlation between Temperature Class and permissible ambient temperature range T_a is shown in Table 2.

Table 2:

Temperature Class	Permissible ambient temperature T _a
T4	-40 °C ≤ T _a ≤ + 80 °C
T6	-40 °C ≤ T _a ≤ + 55 °C

For operation with Inductive Limit Switches (3730-130.....15 or 3730-130.....16) used with I_{max}/I_i = 52 mA and P_i = 169 mW the correlation between Temperature Class and permissible ambient temperature range is shown in Table 3.

Table 3:

Temperature Class	Permissible ambient temperature T _a
T4	-40 °C ≤ T _a ≤ + 70 °C
T6	-40 °C ≤ T _a ≤ + 45 °C

Intrinsically Safe when installed as specified in manufacturer's Installation Manual.

FM approved for Hazardous Locations

Class I, Division 1 and 2, Groups A, B, C, D

Class II, Division 1, Groups E, F, G

Class III, Division 1

Class I, Zone 1, AEx ia IIC T4/T6

Enclosure Type 4X / IP 66

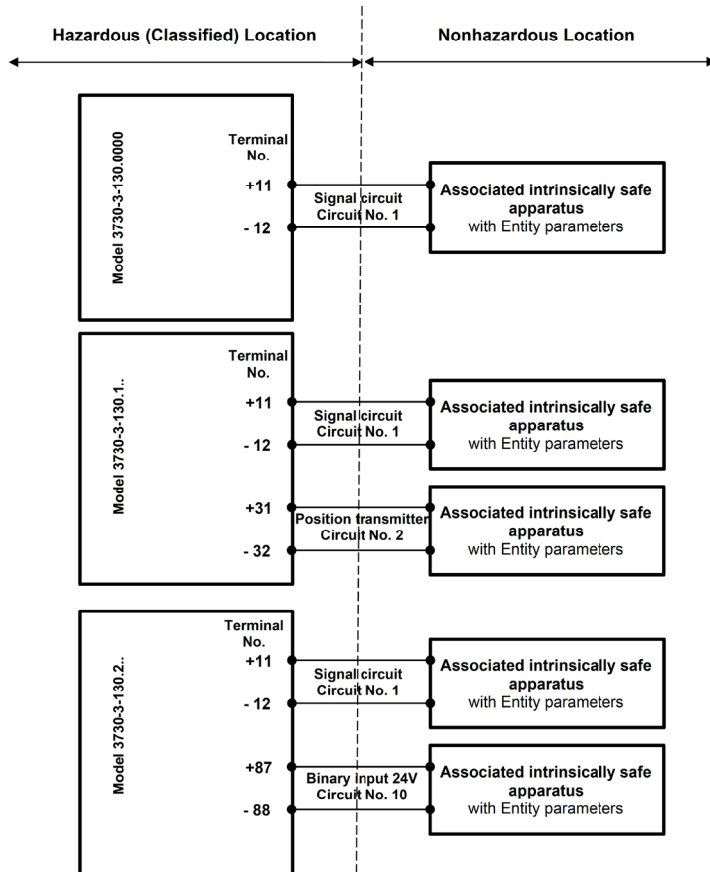

Revision Control Number: 0 / August 2022

Addendum to EB 8484-3 EN

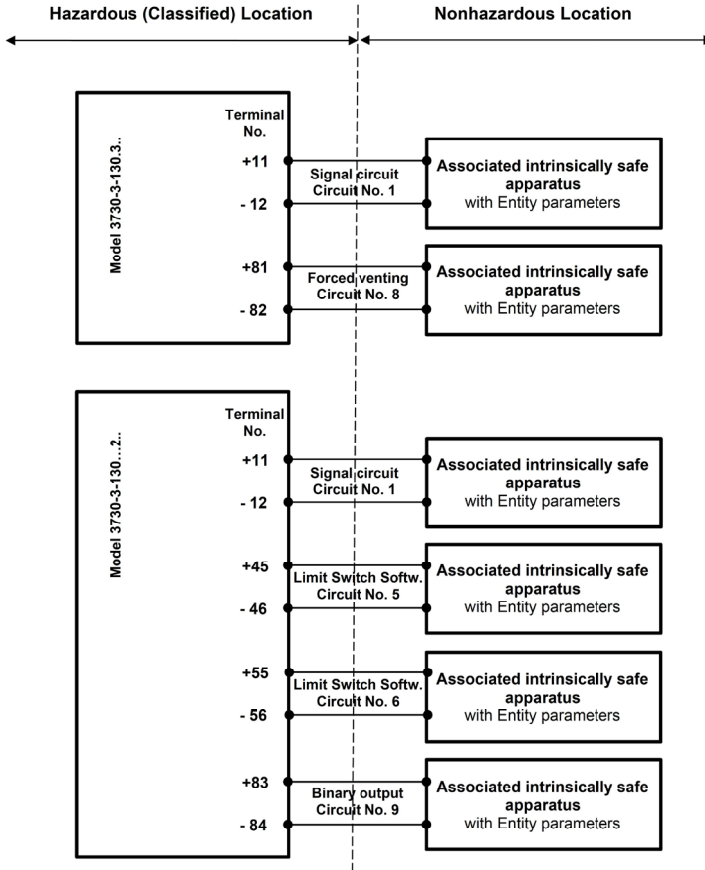

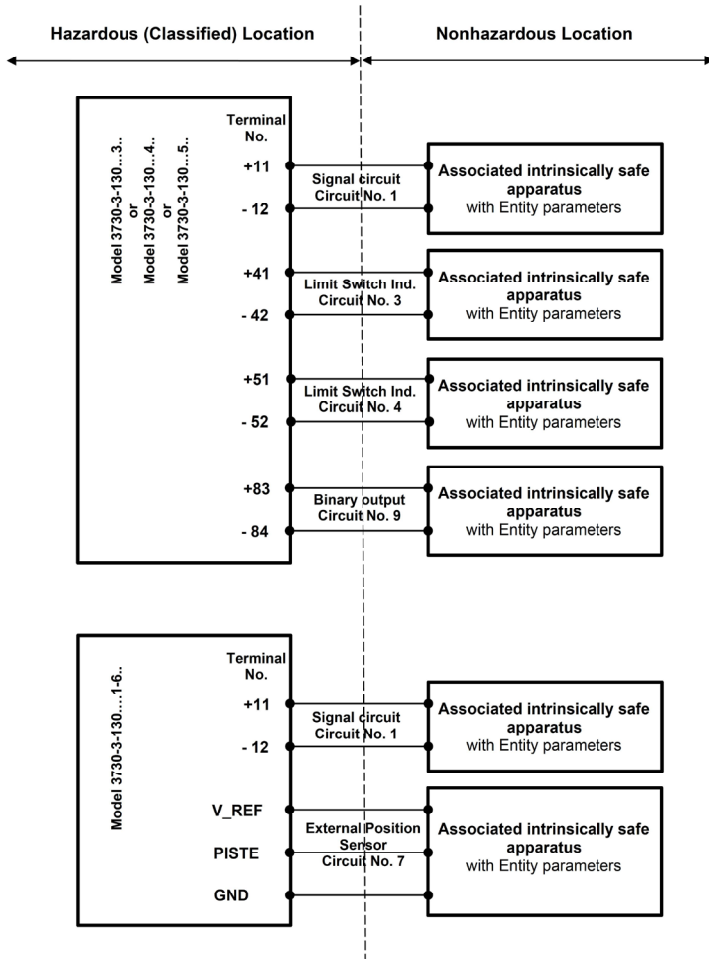

Notes:

1. The apparatus may be installed in intrinsically safe and non-incendive field wiring circuits only when used in conjunction with certified intrinsically safe or non-incendive associated apparatus. For maximum values see Table 1 on page 1.
2. For the interconnection of intrinsically safe and associated intrinsically safe apparatus not specifically examined in combination as a system, the Entity Parameters must meet following requirements:

$$\begin{array}{rcl}
 V_{OC} \text{ or } U_0 & \leq & U_i \text{ or } V_{max} \\
 I_{SC} \text{ or } I_0 & \leq & I_i \text{ or } I_{max} \\
 P_0 & \leq & P_i \text{ or } P_{max} \\
 C_a \text{ or } C_o & \geq & C_i + C_{Cable} \\
 L_a \text{ or } L_o & \geq & L_i + L_{Cable}
 \end{array}$$

3. The installation must be in accordance with Canadian Electrical Code C.E.C. Part 1.
4. The installation must be in accordance with the National Electrical Code NFPA 70 and ANSI/ISA RP 12.06.01.
5. Use only supply wires suitable for 5 °C above surrounding temperature.
6. Substitution of components may impair intrinsic safety.
7. The maximum nonhazardous area voltage must not exceed 250 Vrms.
8. Cable entry M20 x 1.5 or metal conduit

16 Appendix A (configuration instructions)

16.1 Code list

i Note

The availability of executed menu items and parameters depends on the positioner's configuration.

16.1.1 Start screen

Display/numbering	Description
0.1	Reading of the valve position in degrees (when the positioner has not yet been initialized)
0.2	Reading of the valve position in % (when the positioner has been initialized)
0.12	Reading of set point in %
0.15	Reading of set point deviation in %
0.20	Reading of the supply pressure in bar (only positioners with pressure sensors)
0.50	Reading of generated messages
0.99	Press  to go to the menu level.

16.1.2 Main menu and start-up

Menu	Display reading	On-site: write	Diagnostics	Adjustment range/values [default setting]/description
Main menu	•	•	•	
Current operating mode	–	•	•	→ SAFE, AUTO, MAN, Open-loop operation, Initialization, Test operation, Factory calibration Reading of the positioner's current operating mode
Target operating mode	1	•	•	→ AUTO, SAFE, [MAN] Selecting the operating mode: – AUTO: automatic mode – SAFE: fail-safe position – MAN: manual mode Switchover from automatic to manual mode is bumpless. This parameter is indicated when the positioner has been initialized or not initialized with the MAN initialization mode.
Set point (open-loop control)	2	•	•	→ -34.0 to 34.0° [-30.0°] Enter the set point for the open-loop control mode. The reading in degrees is not absolute and only intended as a guide. Note: The open-loop control mode is active when the positioner that has not yet been initialized.
Manual set point (MAN)	3	•	•	→ -25.0 to 125.0 % [0.0 %] The set point for manual mode (MAN) set with the rotary pushbutton. The current travel/angle is indicated in % when the positioner is initialized. Note: Only when the positioner is in the MAN operating mode.
Reason for fail-safe position	4	•	•	→ [---], Not active, User specifications, No x signal, IP shutdown, Forced venting function, Angle limitation, Hardware error, Forced venting switch incorrect Reason for change to fail-safe position displayed. The parameter appears when the positioner is in the fail-safe position mode. Note: Only when the positioner is in the SAFE operating mode.
Change reading direction or Reading direction ¹⁾	5	•	•	→ [Reading direction], [Pneumatics (right)] or [Pneumatics (left)] ¹⁾ Select the reading direction in the display
Tag no.	–	–	•	Empty text box to enter tag details (max. 8 characters)
Tag no. (long)	–	–	•	Empty text box to enter tag details (max. 32 characters)
User level	6			→ [On-site: read], On-site: write On-site configuration at the positioner is unlocked (revoked if no settings are entered within five minutes).

Menu	Display reading	On-site: write	Diagnostics	Adjustment range/values [default setting]/description
Start-up	7	•	•	
Actuator	7.1	•	•	<p>→ [Linear actuator], Rotary actuator, Linear actuator (expert) Select the actuator type: Linear actuator: the pin position (in mm) can be selected from the listed values in the 7.2 parameter. Rotary actuator: the '90°' pin position can be selected in the 'Pin position for rotary actuator' [7.6] parameter. Linear actuator (expert): infinitely variable setting options for pin position (parameter in 7.4) and nominal range (parameter in 7.12)</p>
Pin position	7.5	•	•	<p>→ [None], 17, 25, 35, 50, 70, 100, 200, 300 mm Enter the current position of the follower pin. The pin position depends on the rated travel of the linear actuator (see the 'Start-up and configuration' chapter). Note: Only with 'Actuator' = 'Linear actuator'</p>
Pin position	7.6	•	•	<p>→ 90° Enter the current position of the follower pin. The pin position depends on the nominal angle of the rotary actuator (see the 'Start-up and configuration' chapter). Note: Only with 'Actuator' = 'Rotary actuator'</p>
Pin position	7.7	•	•	<p>→ [10] to 655 mm Enter the current position of the follower pin. The pin position depends on the rated travel of the linear actuator (see the 'Start-up and configuration' chapter). Note: Only with 'Actuator' = 'Linear actuator (expert)'</p>
Nominal range	7.10	•	•	<p>→ 3.6 to 655 mm (depending on the selected pin position) Infinitely variable setting of the nominal range in mm The adjustment range depends on the pin position entered in 'Pin position for linear actuator'. Note: Only with 'Actuator' = 'Linear actuator'</p>
Nominal range	7.11	•	•	<p>→ 24.0 to 100.0° [90.0°] Infinitely variable setting of the nominal range in degrees The adjustment range depends on the pin position entered in 'Pin position for rotary actuator'. Note: Only with 'Actuator' = 'Rotary actuator'</p>
Nominal range for linear actuator (expert) or Nominal range ¹⁾	7.12	•	•	<p>→ [3.6] to 999.0 mm Infinitely variable setting of the nominal range in mm The adjustment range depends on the pin position entered in 'Pin position for linear actuator (expert)'. Note: Only with 'Actuator' = 'Linear actuator (expert)'</p>

Appendix A (configuration instructions)

Menu	Display reading	On-site: write	Diagnostics	Adjustment range/values [default setting]/description
Max. nom. range	7.16	•	•	Indicates the maximum possible nominal range. Note: Only positioners initialized with MAX initialization mode and 'Pin position for linear actuator' ≠ 'None'.
Detected nominal range	7.17	•	•	Indicates the determined nominal range for rotary actuators. Note: Only positioners initialized with MAX initialization mode
Fail-safe position	7.20	•	•	Indicates the fail-safe position (Air-to-open (ATO), Air-to-close (ATC)) set at the slider switch
Initialization mode	7.24	•	•	→ [MAX], NOM, MAN, SUB Select the initialization mode: – MAX: travel/angle of the closure member from the closed position to the opposite stop in the actuator – NOM: travel/angle of the closure member measured from the closed position to the specified rated travel – MAN: manually selected range – SUB: substitute calibration (without initialization) See the 'Start-up and configuration' chapter for details on initialization modes.
Set point (open-loop control)	7.28	•	•	→ -35.0 to 35.0° [-30.0°] Set point for initialization with MAN initialization mode. The reading in degrees is not absolute and only intended as a guide. Note: Only when initialization mode = MAN.
Adopt valve position 1	7.29	•	•	→ Confirm the first end position of the valve (see the 'Start-up and configuration' chapter). Note: Only when initialization mode = MAN.
First valve position	7.30	•	•	Reading of the first end position of the valve (lever position in degrees) Note: Only when initialization mode = MAN.
Adopt valve position 2	7.31	•	•	→ Confirm the second end position of the valve (see the 'Start-up and configuration' chapter). Note: Only when initialization mode = MAN.
Second valve position	7.32	•	•	Reading of the second end position of the valve (lever position in degrees) Note: Only when initialization mode = MAN.
Current valve position	7.35	•	•	→ -25.0 to 125.0 % [0.0 %] Current valve position Note: Only when initialization mode = SUB.

Menu	Display reading	On-site: write	Diagnostics	Adjustment range/values [default setting]/description
Direction of rotation	7.36	•	•	<p>→ Counterclockwise, [Clockwise]</p> <p>Determine the lever's direction of rotation for MAN initialization mode. For example: The valve closes when the plug stem moves downward. This action causes the positioner's lever to turn counterclockwise (when looking at the display, the pneumatic module on the right)</p> <p>→ Setting: counterclockwise</p> <p>Note: Only when initialization mode = SUB.</p>
Volume booster	7.51	•	•	<p>→ [Not available], Available</p> <p>If the positioner is combined with a volume booster, this parameter must be set accordingly.</p>
Direction of action (actuator)	7.52	•	•	<p>→ [Single-acting], Double-acting</p>
Reversing amplifier	7.52	•	•	<p>→ [Not available], Available</p> <p>If a reversing amplifier is connected to the positioner, this parameter must be set accordingly.</p>
Pressure limit active	7.57	•	•	<p>→ [No], Yes</p>
Pressure limit	7.58	•	•	<p>→ Not active, 1.4 bar, 2.4 bar, 3.7 bar, [4.7 bar]</p> <p>Enter value for pressure limit in bar.</p> <p>Do not activate pressure limitation for double-acting actuators (with fail-safe position AIR TO OPEN).</p> <p>Note: Only positioners with pressure sensors and with 'Pressure limit active' = 'Yes'</p>
Initialization including valve signature	7.68	•	•	<p>→ [Yes], No</p> <p>The valve signature is recorded after initialization is completed. In this case, the signal pressure is recorded together with the valve position and saved in the positioner as a reference value.</p>
Start initialization	7.75	•	•	<p>→ Confirm to start initialization</p> <p>During initialization, the valve moves through its travel range.</p>
Stop initialization	–	•	•	<p>→ Confirm to stop initialization</p>
Start zero calibration	7.76	•	•	<p>→ Confirm to start zero calibration</p> <p>During zero calibration, the valve moves through its travel range.</p>
Stop zero calibration	–	–	•	<p>→ Confirm to stop zero calibration</p>
Result of last initialization	7.83	•	•	<p>Indicates whether the last initialization was successfully completed. The reason why an unsuccessful initialization was canceled is indicated.</p>

Appendix A (configuration instructions)

Menu	Display reading	On-site: write	Diagnostics	Adjustment range/values [default setting]/description
Result of last zero calibration	7.84	•	•	Indicates whether the last zero calibration was successfully completed. The reason why an unsuccessful zero calibration was canceled is indicated.
Result of last valve signature	7.85	•	•	Indicates whether the last valve signature was successfully completed. The reason why the recording of an unsuccessful valve signature was canceled is indicated.
Initialization status	–	–	•	Indicates whether initialization is active or inactive.
Zero calibration status	–	–	•	Indicates whether zero calibration is active or inactive.
Reset initialization	–	–	•	
Current initialization	–	–	•	After initialization starts, the values and settings used as the basis for the initialization are listed in the following parameters. Contrary to the [Valid initialization] folder, this list of values is saved even if the initialization is not completed successfully.
Actuator	–	–	•	Indicates the 'Actuator' parameter [7.1] specified for initialization.
Pin position	–	–	•	Indicates the 'Pin position' parameter [7.5, 7.6 or 7.7] specified for initialization.
Fail-safe position	–	–	•	Indicates the 'Fail-safe position' parameter [7.20] specified for initialization.
Initialization mode	–	–	•	Indicates the 'Initialization mode' parameter [7.24] specified for initialization.
Volume booster	–	–	•	Indicates the 'Volume booster' parameter [7.51] specified for initialization.
Direction of action (actuator)	–	–	•	
Reversing amplifier	–	–	•	Indicates the 'Reversing amplifier' parameter [7.52] specified for initialization.
Pressure limit active	–	–	•	
Pressure limit	–	–	•	Indicates the 'Pressure limit' parameter [7.58] specified for initialization.
Dead time (open)	–	–	•	Indicates the dead time to open during initialization in ms.
T63 (open)	–	–	•	Indicates the opening time (in ms) recorded during initialization for a step change from 0 to 63 %.
T86 (open)	–	–	•	Indicates the opening time (in ms) recorded during initialization for a step change from 0 to 86 %.
T98 (open)	–	–	•	Indicates the opening time (in ms) recorded during initialization for a step change from 0 to 98 %.

Menu	Display reading	On-site: write	Diagnostics	Adjustment range/values [default setting]/description
Dead time (close)	–	–	•	Indicates the dead time to close during initialization in ms.
T63 (close)	–	–	•	Indicates the closing time (in ms) recorded during initialization for a step change from 100 to 27 %.
T86 (close)	–	–	•	Indicates the closing time (in ms) recorded during initialization for a step change from 100 to 14 %.
T98 (close)	–	–	•	Indicates the closing time (in ms) recorded during initialization for a step change from 100 to 2 %.
Direction of rotation	–	–	•	Indicates the 'Direction of rotation' parameter [7.36] specified for initialization.
Nominal range (optimized)	–	–	•	Indicates the nominal range measured with the activated speed-based end position.
Detected nominal range	–	–	•	Indicates the nominal range for rotary actuators determined during initialization
Time stamp	–	–	•	Indicates time (reading of operating hours counter) when the initialization was performed.
Temperature	–	–	•	Indicates the temperature inside the device determined during initialization.
Dead band (integral-action component)	–	–	•	Indicates the integral dead band determined during initialization
Loop gain (supply)	–	–	•	Indicates the loop gain for supply determined during initialization.
Loop gain (exhaust)	–	–	•	Indicates the loop gain for exhaust determined during initialization.
Valid initialization	7.95	•	•	After initialization has been completed successfully, the values and settings used as the basis for the initialization are listed in the following parameters.
Actuator	7.95.1	•	•	Indicates the 'Actuator' parameter [7.1] specified for initialization.
Pin position	7.95.5	•	•	Indicates the 'Pin position' parameter [7.5] specified for initialization.
Pin position	7.95.6	•	•	Indicates the 'Pin position' parameter [7.6] specified for initialization.
Pin position	7.95.7	•	•	Indicates the 'Pin position' parameter [7.7] specified for initialization.
Fail-safe position	7.95.20	•	•	Indicates the 'Fail-safe position' parameter [7.20] specified for initialization.
Initialization mode	7.95.24	•	•	Indicates the 'Initialization mode' parameter [7.24] specified for initialization.

Appendix A (configuration instructions)

Menu	Display reading	On-site: write	Diagnostics	Adjustment range/values [default setting]/description
Volume booster	7.95.51	•	•	Indicates the 'Volume booster' parameter [7.51] specified for initialization.
Direction of action (actuator)	–	–	•	
Reversing amplifier	7.95.52	•	•	Indicates the 'Reversing amplifier' parameter [7.52] specified for initialization.
Pressure limit active	–	–	•	
Pressure limit	7.95.58	•	•	Indicates the 'Pressure limit' parameter [7.58] specified for initialization.
Dead time (open)	–	–	•	Indicates the dead time to open during initialization in ms.
T63 (open)	–	–	•	Indicates the opening time (in ms) recorded during initialization for a step change from 0 to 63 %.
T86 (open)	–	–	•	Indicates the opening time (in ms) recorded during initialization for a step change from 0 to 86 %.
T98 (open)	7.95.70	–	•	Indicates the opening time (in ms) recorded during initialization for a step change from 0 to 98 %.
Dead time (close)	–	–	•	Indicates the dead time to close during initialization in ms.
T63 (close)	–	–	•	Indicates the closing time (in ms) recorded during initialization for a step change from 100 to 27 %.
T86 (close)	–	–	•	Indicates the closing time (in ms) recorded during initialization for a step change from 100 to 14 %.
T98 (close)	7.95.74	–	•	Indicates the closing time (in ms) recorded during initialization for a step change from 100 to 2 %.
Direction of rotation	–	–	•	Indicates the 'Direction of rotation' parameter [7.36] specified for initialization.
Nominal range (optimized)	–	–	•	Indicates the nominal range measured with the activated speed-based end position.
Detected nominal range	–	–	•	Indicates the nominal range for rotary actuators determined during initialization
Time stamp	–	–	•	Indicates time (reading of operating hours counter) when the initialization was performed.
Temperature	–	–	•	Indicates the temperature inside the device determined during initialization.
Supply pressure during last initialization	–	–	•	Indicates the supply pressure determined during initialization
Dead band (integral-action component)	–	–	•	Indicates the integral dead band determined during initialization

Menu	Display reading	On-site: write	Diagnostics	Adjustment range/values [default setting]/description
Loop gain (supply)	7.95.80	–	•	Indicates the loop gain for supply determined during initialization.
Loop gain (exhaust)	7.95.87	–	•	Indicates the loop gain for exhaust determined during initialization.

Configuration

Menu	Display reading	On-site: write	Diagnostics	Adjustment range/values [default setting]/description
Configuration	8	•	•	
On-site operation locked	–	–	•	→ Yes, [No] Indicates whether on-site operation is locked over the device integration.
Language of on-site operation	–	–	•	→ [Default], Language 1, Language 2, ..., Language 5 Language used on the positioner display
Behavior upon failure of the travel sensing	–	–	•	→ [Emergency mode], Fail-safe position Select how the positioner is to behave when the travel sensing fails. – Emergency mode: the positioner behaves as if it is not initialized (open-loop control) – Fail-safe position: the positioner moves the valve to the defined fail-safe position (see 7.20 parameter)
Activate password	–	–	•	→ Active, [Not active] On-site: write: indicates whether the password is activated or not. Diagnosis: activate/deactivate the password to lock on-site operation
Change password	–	–	•	→ 0000 to 9999, [1234] → Change the password.

Appendix A (configuration instructions)

Menu	Display reading	On-site: write	Diagnostics	Adjustment range/values [default setting]/description
Set point processing	8.1	•	•	
Lower w-range value	8.1.1	•	•	<p>→ [0.0] to 75.0 %</p> <p>The lower set point range value must be lower than 'Upper w-range value', 0 % = 4 mA.</p> <p>The set point range is the difference between 'Upper w-range value' and 'Lower w-range value' and must be $\Delta w \geq 25\% = 4$ mA.</p> <p>When the set point range of 0 to 100 % = 4 to 20 mA, the valve must move through its entire operating range from 0 to 100 % travel/angle of rotation.</p> <p>In split-range operation, the valves operate with smaller set points. The control signal of the control unit to control two valves is divided such, for instance, that the valves move through their full travel/angle of rotation at only half the input signal (first valve set to 0 to 50 % = 4 to 12 mA and second valve set to 50 to 100 % = 12 to 20 mA).</p>
Upper w-range value	8.1.2	•	•	<p>→ 25.0 to [100.0 %]</p> <p>See 'Lower w-range value' parameter [8.1.1]</p> <p>The upper range value of the set point range must be greater than 'Lower w-range value'.</p>
Direction of action	8.1.6	•	•	<p>→ [Increasing/increasing], Increasing/decreasing</p> <p>The set point's effect on the valve position is determined as follows:</p> <ul style="list-style-type: none"> – Increasing/increasing: a globe valve opens as the set point increases. – Increasing/decreasing: a globe valve closes as the set point increases.
Characteristic	8.1.9	•	•	<p>→ [Linear], Equal percentage, Reverse equal percentage, Butterfly valve (linear), Butterfly valve (equal percentage), Rotary plug valve (linear), Rotary plug valve (equal percentage), Segmented ball valve (linear), Segmented ball valve (equal percentage), User-defined</p> <p>Select the characteristic (see Chapter 16.3).</p>
Lower x scaling	8.1.10	•	•	<p>→ [0.0] to 80 %</p> <p>Indicates the defined lower range value of the set point range.</p>
Upper x scaling	8.1.11	•	•	<p>→ 20.0 to [100 %]</p> <p>Indicates the defined upper range value of the set point range.</p>

Menu	Display reading	On-site: write	Diagnostics	Adjustment range/values [default setting]/description
Lower x-range value	8.1.12	•	•	<p>→ [0.0] to 99.0 %</p> <p>Lower range value for travel/angle in nominal or operating range</p> <p>The operating range is the actual travel/angle of the valve and is limited by the lower travel/angle range value and the upper travel/angle range value. Usually, the operating range and the nominal range are identical. The nominal range can be limited to the operating range by the lower and upper x-range values. The value is displayed or must be entered. The characteristic is adapted. The difference between the lower and upper x-range values must be at least 1 %.</p>
Upper x-range value	8.1.13	•	•	<p>→ 1.0 to [100.0 %]</p> <p>Upper range value for travel/angle in nominal or operating range</p> <p>The value is displayed or must be entered.</p> <p>The characteristic is adapted.</p> <p>Example: The operating range is modified, for example to limit the range of a control valve which has been sized too large. For this function, the entire resolution range of the set point is converted to the new limits.</p> <p>0 % on the display corresponds to the adjusted lower limit and 100 % to the adjusted upper limit.</p> <p>The difference between the lower and upper x-range values must be at least 1 %.</p>
Ramp time (rising)	8.1.20	•	•	<p>→ [0.0] to 10000.0 s</p> <p>Time required by the valve to move through its working range with an increasing set point.</p> <p>For some applications it is recommendable to limit the transit time of the actuator to prevent it from engaging too fast in the running process.</p>
Ramp time (falling)	8.1.22	•	•	<p>→ [0.0] to 10000.0 s</p> <p>Time required by the valve to move through its working range with a set point to open the valve.</p> <p>For some applications it is recommendable to limit the transit time of the actuator to prevent it from engaging too fast in the running process.</p>
Travel/sec. (rising)	8.1.25	–	–	<p>→ 1.0 to 100.0 % [10.0 %]</p> <p>Required travel change in % per second</p>
Travel/sec. (falling)	8.1.27	–	–	<p>→ 1.0 to 100.0 % [10.0 %]</p> <p>Required travel change in % per second</p>

Appendix A (configuration instructions)

Menu	Display reading	On-site: write	Diagnostics	Adjustment range/values [default setting]/description
Lower end position	8.1.40	•	•	→ [Activated], Deactivated Activate/deactivate the 'End position w <=' (set point cutoff decrease) parameter A tight-closing of the valve is only effective when 'Lower end position' = 'Active'.
End position w <= (set point cutoff decrease)	8.1.41	•	•	→ 0.0 to 49.0 % [1.0 %] If the set point w reaches up to the entered percentage at the final value that causes the valve to close, the actuator is immediately completely vented (with AIR TO OPEN) or filled with air (with AIR TO CLOSE). This action always lead to maximum tight-closing of the valve. Note: Parameter only active when 'Lower end position' = 'Active'.
Upper end position	8.1.44	•	•	→ Activated, [Deactivated] Activate/deactivate the 'End position w >=' (set point cutoff increase) parameter For three-way valves, the following must apply: 'Upper end position' = 'Active'.
End position w >= (set point cutoff increase)	8.1.45	•	•	→ 51.0 to 100.0 % [99.0 %] If the set point w reaches up to the entered percentage at the final value that causes the valve to open, the actuator is immediately filled with air (with AIR TO OPEN) or completely vented (with AIR TO CLOSE). This action leads to the valve being completely opened when it is working properly. Example: set the 'End position w >=' (set point cutoff increase) parameter to 99 % for three-way valves. Note: Parameter only active when 'Upper end position' = 'Active'.
Identification	8.2	•	•	
Positioner	8.2.1	•	•	
Article code	–	–	•	Reading of the positioner article code The article code helps identify the positioner version (see the 'Markings on the device' chapter).
Certification	–	–	•	Indicates whether the positioner has a valid explosion protection certificate.
SIL deactivation behavior	–	–	•	Indicates the set point for the safety-instrumented function 'Emergency venting' (≤3.8 mA)
Order number and order position	–	–	•	Indicates the order number and position when the positioner was ordered (operator details on ordering).
Control valve ID	–	–	•	Indicates the ID of the control valve on which the positioner is mounted (operator details on ordering).

Menu	Display reading	On-site: write	Diagnostics	Adjustment range/values [default setting]/description
Identification link	–	–	•	Unique identification of the positioner (assigned by SAMSON)
Firmware version	8.2.1.5	•	•	Reading of the positioner firmware version
Hardware version	8.2.1.6	•	•	Reading of the positioner hardware version
Serial number	8.2.1.7	•	•	Indicates the serial number of the positioner
Configuration ID assigned to the device	–	–	•	Indicates the configuration ID of the positioner
Date: day	–	–	•	→ [1] to 31
Date: month	–	–	•	→ [1] to 12
Date: year	–	–	•	→ 1900 to 2155 [2012]
Message	–	–	•	Empty text box to enter a message (max. 32 characters)
Text box 1	–	–	•	Empty text boxes to enter information on the positioner, control valve and/or tag (max. 32 characters)
Text box 2	–	–	•	
Text box 3	–	–	•	
Text box 4	–	–	•	
Text box 5	–	–	•	
Valve	–	–	•	
Valve manufacturer	–	–	•	Option to enter valve manufacturer (max. 32 characters)
Description	–	–	•	Option to enter description of the valve (max. 32 characters)
Actuator motion	–	–	•	→ Linear motion, Rotary motion, Other, [-/-]
Valve size standard	–	–	•	→ DIN, ANSI, IG, JIS, BS, Other (mm), Other (in), [-/-]
Nominal size DN	–	–	•	→ [0.0] to 65535.0
Flow direction	–	–	•	→ Flow-to-open, Flow-to-close, Alternating, [-/-]
Max. cycle count	–	–	•	→ 0 to 1000000000, [1000000]
Pressure balancing	–	–	•	→ Without, With (PTFE), With (graphite), Other, [-/-]
Facing (leakage class)	–	–	•	→ Metal seal, Lapped-in, Soft seal, Nickel seal, PTFE, PEEK, UHMWPE, FFKM, UHMWPE (polyethylene), Other, [-/-]
Valve seat diameter	–	–	•	→ [0.0] to 600.0 mm
Kvs	–	–	•	→ [0.0] to 10000.00
Kvs unit	–	–	•	→ Kv coefficient, Tv, Other, [-/-]
Plug type	–	–	•	→ Parabolic, V-port, Other, [-/-]

Appendix A (configuration instructions)

Menu	Display reading	On-site: write	Diagnostics	Adjustment range/values [default setting]/description
Valve characteristic	-	-	•	→ Linear, Equal percentage, Inherent, Other, [-/-]
Noise reduction	-	-	•	→ None, St I, St II, St III, Other, [-/-]
Actuator	-	-	•	
Actuator manufacturer	-	-	•	Option to enter actuator manufacturer (max. 32 characters)
Description	-	-	•	Option to enter description of the actuator (max. 32 characters)
Actuator motion	-	-	•	→ Linear motion, Rotary motion, Other, [-/-]
Principle of operation	-	-	•	→ Single acting, Double acting, Other, [-/-]
Actuator type	-	-	•	→ Pneumatic (diaphragm), Pneumatic (piston), Hydraulic, Electric, Other, [-/-]
Effective actuator area	-	-	•	→ [0] to 65535 cm ²
Lower signal pressure range value	-	-	•	→ [0.0] to 65535.0 bar
Upper signal pressure range value	-	-	•	→ [0.0] to 65535.0 bar [1.0 bar]
Fail-safe position	-	-	•	→ Air-to-open (ATO), Air-to-close (ATC), Other, [-/-]
Supply pressure	-	-	•	→ [0.0] to 14.0 bar
Further valve accessories	-	-	•	
Manufacturer	-	-	•	Option to enter manufacturer of valve accessories (max. 32 characters)
Description	-	-	•	Option to enter description of the valve accessories (max. 32 characters)
Control parameters	8.7	•	•	
Activate integral-action component	8.7.1	•	•	<p>→ [Active] (PID), Not active (PD)</p> <p>The control mode can be changed from PD to PID controller and vice versa.</p> <p>The integral action of the PID controller is always activated after initialization has been completed successfully. It can be deactivated by this parameter. After it is deactivated, the positioner merely works as a PD controller. As a result, the positioner responds more slowly or not all to very small set point deviations. We recommend activating integral action for very precise closed-loop control.</p>

Menu	Display reading	On-site: write	Diagnostics	Adjustment range/values [default setting]/description
Dead band (integral-action component)	8.7.2	•	•	<p>→ [0.1] to 100.0 %</p> <p>Integral dead band for closed-loop control</p> <p>The integral action stops when the set point deviation enters this dead band.</p> <p>The integral action restarts when the valve position leaves the dead band again.</p> <p>The adaptation is carried out automatically during closed-loop control (depending on the friction).</p>
Deactivation of integral action in upper end position	8.7.3	•	•	<p>→ 0 to 25 % [1.0 %]</p> <p>The integral action stops when the valve position is above this limit.</p> <p>The integral action is no longer included in closed-loop control if a steady-state error arises around the upper end position (e.g. increased friction, end position cannot be reached). The integral action restarts when the valve position leaves the described range again.</p> <p>Example: if this parameter is set to 1 %, the integral action stops for valve positions >99 %.</p>
Deactivation of integral action in lower end position	8.7.4	•	•	<p>→ 0 to 25 % [1.0 %]</p> <p>The integral action stops when the valve position is below this limit.</p> <p>The integral action is no longer included in closed-loop control if a steady-state error arises around the lower end position (e.g. increased friction, end position cannot be reached). The integral action restarts when the valve position leaves the described range again.</p> <p>Example: if this parameter is set to 1 %, the integral action stops for valve positions <1 %.</p>
Adaptation of integral-action component	8.7.6	•	•	<p>→ [Active], Not active</p> <p>Activate/deactivate automatic adaptation of integral-action component.</p>
Current dead band (integral-action component)	8.7.8	•	•	<p>Reading of current dead band of the integral-action component for closed-loop control</p> <p>The integral action stops when the set point deviation enters this dead band.</p> <p>The integral action restarts when the valve position leaves the dead band again.</p> <p>The adaptation is carried out automatically during closed-loop control (depending on the friction).</p>
User-defined control parameters	8.7.10	•	•	<p>→ Active, [Not active]</p> <p>Activate/deactivate the settings for gain (Kp, Ki, Kd).</p>

Appendix A (configuration instructions)

Menu	Display reading	On-site: write	Diagnostics	Adjustment range/values [default setting]/description
Loop gain (supply)	8.7.13	•	•	→ 1 to 650 [50] Setting of loop gain Note: Parameter only active when 'User-defined control parameters' = 'Not active'.
Kp (supply)	8.7.15	•	•	→ 0.1 to 200.0 [1.0] Setting of the proportional gain for supply During positioner initialization, the parameters of the PID controller are optimally tuned. If the valve oscillates at a position, lowering the Kp after initialization can lead to an improvement. Check the integral and derivative action for their correct response after adjusting Kp. Note: Parameter only active when 'User-defined control parameters' = 'Active'.
Ki (supply)	8.7.16	•	•	→ 0.1 to 100.0 [1.0] Setting of the integral gain for supply During positioner initialization, the parameters of the PID controller are optimally tuned. If the error is too large in steady state, increasing the Ki after initialization can lead to an improvement. Check the proportional and derivative action for their correct response after adjusting Ki. Note: Parameter only active when 'User-defined control parameters' = 'Active'.
Kd (supply)	8.7.17	•	•	→ 0.5 to 200.0 [2.0] Setting of the derivative gain for supply During positioner initialization, the parameters of the PID controller are optimally tuned. If the valve oscillates at a position, raising the Kd after initialization can lead to an improvement. Check the proportional and integral action for their correct response after adjusting Kp. Note: Parameter only active when 'User-defined control parameters' = 'Active'.
Loop gain (exhaust)	8.7.20	•	•	→ 1 to 650 [50] Setting of loop gain Note: Parameter only active when 'User-defined control parameters' = 'Not active'.

Menu	Display reading	On-site: write	Diagnostics	Adjustment range/values [default setting]/description
Kp (exhaust)	8.7.22	•	•	<p>→ 0.1 to 200.0 [1.0]</p> <p>Setting of the proportional gain for exhaust</p> <p>During positioner initialization, the parameters of the PID controller are optimally tuned. If the valve oscillates at a position, lowering the Kp after initialization can lead to an improvement.</p> <p>Check the integral and derivative action for their correct response after adjusting Kp.</p> <p>Note: Parameter only active when 'User-defined control parameters' = 'Active'.</p>
Ki (exhaust)	8.7.23	•	•	<p>→ 0.1 to 100.0 [1.0]</p> <p>Setting of the integral gain for exhaust</p> <p>During positioner initialization, the parameters of the PID controller are optimally tuned. If the error is too large in steady state, increasing the Ki after initialization can lead to an improvement.</p> <p>Check the proportional and derivative action for their correct response after adjusting Ki.</p> <p>Note: Parameter only active when 'User-defined control parameters' = 'Active'.</p>
Kd (exhaust)	8.7.24	•	•	<p>→ 0.5 to 200.0 [2.0]</p> <p>Setting of the gain factor of the derivative component for the set point deviation in the PID controller for exhaust</p> <p>During positioner initialization, the parameters of the PID controller are optimally tuned. If the valve oscillates at a position, raising the Kd after initialization can lead to an improvement.</p> <p>Check the proportional and integral action for their correct response after adjusting Kp.</p> <p>Note: Parameter only active when 'User-defined control parameters' = 'Active'.</p>
Software restriction (supply)	8.7.30	•	•	<p>→ 25 to 100 %</p> <p>Setting of the supply flow rate restriction in % of the pneumatic module (slot A)</p> <p>The supply flow rate of the pneumatic modules is reduced to the specified value. A reduction of the flow rate may lead to a better control accuracy for small actuators.</p>

Appendix A (configuration instructions)

Menu	Display reading	On-site: write	Diagnostics	Adjustment range/values [default setting]/description
End position (optimized)	8.7.70	•	•	<p>→ [Active], Not active</p> <p>This parameter only applies to the end position (supply) with MAX initialization mode and an air-to-open (ATO) actuator. In all other cases, this function is deactivated.</p> <p>During initialization, an optimal and a mechanical end position is calculated based on an analysis of the motion speed. The optimized end position is used if the distance is small enough. We recommend only activating this function when a mechanical deformation of the actuator is explicitly specified. In this case, it leads to a higher error in the end position. As a result, the control accuracy worsens.</p>
Options	8.10	•	•	
Module status	8.10.3	•	•	Indicates the status of module A. The module is functional when 'Status' = 'Module active'
Identification	8.10.4	•	•	Indicates the module ID ('Binary input' or 'Position transmitter')
Option A	8.10.6	•	•	
Terminal designation	8.10.6.1	•	•	Indicates the terminals for electrical connection of option A (see the 'Installation' chapter).
Function	8.10.6.2	•	•	Binary input (contact)
Configuration	8.10.6.3	•	•	Contact (0 to 24 V)
Action upon active binary input	8.10.6.4	•	•	<p>→ Switching state (logging), On-site write protection, Start PST, Start FST, Move valve to fixed value</p> <p>Setting of the action which is to be performed when the binary input is activated.</p> <p>Note: Parameter only active when 'Identification' = 'Binary input'</p>
Fixed value over binary input	8.10.6.5	•	•	<p>→ -25.0 to 125.0 % [100.0 %]</p> <p>Setting of the valve position that the valve is to move to when the binary input is activated.</p> <p>Note: Parameter only active when 'Action upon active binary input' = 'Move valve to fixed value'</p>
Edge control	8.10.6.6	•	•	<p>→ [Active = switch closed], Active = switch open</p> <p>Select the switching state at which the action which is to be performed when the binary input is activated.</p> <p>Note: Parameter only active when 'Identification' = 'Binary input'</p>
Current state	8.10.6.7	•	•	<p>Reading of the current state of the binary input</p> <p>Note: Parameter only active when 'Identification' = 'Binary input'</p>

Menu	Display reading	On-site: write	Diagnostics	Adjustment range/values [default setting]/description
Function	8.10.6.66	•	•	Position transmitter Note: Parameter only active when 'Identification' = 'Position transmitter'
Position transmitter's direction of action	8.10.6.67	•	•	→ [Increasing/increasing], Increasing/decreasing Assignment between travel/angle position and output of the position transmitter (4 to 20 mA signal range) Note: Parameter only active when 'Identification' = 'Position transmitter'
Error message at position transmitter	8.10.6.68	•	•	→ [None], Low, High Selects whether and how errors are to be indicated by the position transmitter output (signal current <2.4 mA (Low) or signal current >21.6 mA (High)) Note: Parameter only active when 'Identification' = 'Position transmitter'
Error message in case of 'Function check' condensed state	–	–	•	→ [Yes], No Activate/deactivate the error message in case of 'Function check' condensed state Note: Parameter only active when 'Error message at position transmitter' ≠ 'None'
Error message in case of 'Maintenance required' and 'Out of specification' condensed states	–	–	•	→ [Yes], No Activate/deactivate the error message in case of 'Maintenance required' or 'Out of specification' condensed state Note: Parameter only active when 'Error message at position transmitter' ≠ 'None'
Signal of analog output	8.10.6.69	•	•	Indicates the position transmitter signal in % based on the 0 to 20 mA signal range. Note: Parameter only active when 'Identification' = 'Position transmitter'
Start AO test.	8.10.6.70	•	•	→ Confirm to start the position transmitter function test. Note: Parameter only active when 'Identification' = 'Position transmitter'
Test signal of analog output	8.10.6.71	•	•	→ -10.0 to 110.0 % [0.0 %] Setting of test signal to perform position transmitter function test Note: Parameter only active when 'Identification' = 'Position transmitter'
Test mode	8.10.6.72	•	•	Indicates the status of the position transmitter function test Note: Parameter only active when 'Identification' = 'Position transmitter'
Module status	8.10.9	•	•	Indicates the status of module B. The module is functional when 'Status' = 'Module active'
Identification	8.10.10	•	•	Indicates the module ID ('Binary input', 'Position transmitter' or 'Forced venting')

Appendix A (configuration instructions)

Menu	Display reading	On-site: write	Diagnostics	Adjustment range/values [default setting]/description
Option B	8.10.12	•	•	
Terminal designation	8.10.12.1	•	•	Indicates the terminals for electrical connection of option B (see the 'Installation' chapter).
Function	8.10.12.2	•	•	Binary input (contact)
Configuration	8.10.12.3	•	•	Contact (0 to 24 V)
Action upon active binary input	8.10.12.4	•	•	→ Switching state (logging), On-site write protection, Start PST, Start FST, Move valve to fixed value Setting of the action which is to be performed when the binary input is activated. Note: Parameter only active when 'Identification' = 'Binary input'
Fixed value over binary input	8.10.12.5	•	•	→ -25.0 to 125.0 % [100.0 %] Setting of the valve position that the valve is to move to when the binary input is activated. Note: Parameter only active when 'Action upon active binary input' = 'Move valve to fixed value'
Edge control	8.10.12.6	•	•	→ [Active = switch closed], Active = switch open Select the switching state at which the action which is to be performed when the binary input is activated. Note: Parameter only active when 'Identification' = 'Binary input'
Current state	8.10.12.7	•	•	Reading of the current state of the binary input Note: Parameter only active when 'Identification' = 'Binary input'
Function	8.10.12.66	•	•	Position transmitter Note: Parameter only active when 'Identification' = 'Position transmitter'
Position transmitter's direction of action	8.10.12.67	•	•	→ [Increasing/increasing], Increasing/decreasing Assignment between travel/angle position and output of the position transmitter (4 to 20 mA signal range) Note: Parameter only active when 'Identification' = 'Position transmitter'
Error message at position transmitter	8.10.12.68	•	•	→ [None], Low, High Selects whether and how errors are to be indicated by the position transmitter output (signal current <2.4 mA (Low) or signal current >21.6 mA (High)) Note: Parameter only active when 'Identification' = 'Position transmitter'

Menu	Display reading	On-site: write	Diagnostics	Adjustment range/values [default setting]/description
Error message in case of 'Function check' condensed state	–	–	•	→ [Yes], No Activate/deactivate the error message in case of 'Function check' condensed state Note: Parameter only active when 'Error message at position transmitter' ≠ 'None'
Error message in case of 'Maintenance required' and 'Out of specification' condensed states	–	–	•	→ [Yes], No Activate/deactivate the error message in case of 'Maintenance required' or 'Out of specification' condensed state Note: Parameter only active when 'Error message at position transmitter' ≠ 'None'
Signal of analog output	8.10.12.69	•	•	Indicates the position transmitter signal in % based on the 0 to 20 mA signal range. Note: Parameter only active when 'Identification' = 'Position transmitter'
Start AO test.	8.10.12.70	•	•	→ Confirm to start the position transmitter function test. Note: Parameter only active when 'Identification' = 'Position transmitter'
Test signal of analog output	8.10.12.71	•	•	→ -10.0 to 110.0 % [0.0 %] Setting of test signal to perform position transmitter function test Note: Parameter only active when 'Identification' = 'Position transmitter'
Test mode	8.10.12.72	•	•	Indicates the status of the position transmitter function test Note: Parameter only active when 'Identification' = 'Position transmitter'
Module status	8.10.20	•	•	Indicates the status of 'Limit switches' module. The limit switches are functional when 'Status' = 'Module active'
Identification	8.10.21	•	•	Indicates the module ID ('Software limit switches PLC', 'NAMUR inductive + software limit switches', 'NAMUR software limit switches' or 'NAMUR inductive limit switches')
Limit switch 1	8.10.22	•	•	
Terminal designation	8.10.22.1	•	•	Indicates the terminals for electrical connection of limit switches option (see the 'Installation' chapter).
Function	8.10.22.20	•	•	→ [Software limit switch], Fault alarm output Select the function: – Software limit switch: Indicates limit violation (above and below limit) – Fault alarm output: indicates existing error messages with 'Failure' status classification and condensed state according to 'Error message in case of ... condensed state' message.

Appendix A (configuration instructions)

Menu	Display reading	On-site: write	Diagnostics	Adjustment range/values [default setting]/description
Mode	8.10.22.21	•	•	→ [Below limit], Above limit Determines whether the software limit switch is to be activated when the value exceeds or falls below the adjusted limit. Note: Parameter only active when 'Function' = 'Software limit switch'
Edge control	8.10.22.22	•	•	→ [Conducting/high], Non-conducting/low Determines in which state the software limit switch is active. Note: Parameter only active when 'Function' = 'Software limit switch'
Error message in case of 'Function check' condensed state	–	–	•	→ [Yes], No Activate/deactivate the error message in case of 'Function check' condensed state Note: Parameter only active when 'Function' = 'Fault alarm output'
Error message in case of 'Maintenance required' and 'Out of specification' condensed states	–	–	•	→ [Yes], No Activate/deactivate the error message in case of 'Maintenance required' or 'Out of specification' condensed state Note: Parameter only active when 'Function' = 'Fault alarm output'
Limit	8.10.22.25	•	•	→ -20.0 to 120.0 % [2.0 %] Determines the limit for the response of the software limit switch Note: Parameter only active when 'Function' = 'Fault alarm output'
Current state	8.10.22.26	•	•	Indicates the status of the software limit switch or fault alarm output.
Start DO test.	8.10.22.27	•	•	→ Confirm to start the function test of the software limit switch or fault alarm output.
Test mode	8.10.22.28	•	•	Indicates the DO test status (function test of the software limit switch or fault alarm output).
Limit switch 2	8.10.23	•	•	
Terminal designation	8.10.23.1	•	•	Indicates the terminals for electrical connection of limit switches option (see the 'Installation' chapter).
Function	8.10.23.20	•	•	→ [Software limit switch], Fault alarm output Select the function: – Software limit switch: Indicates limit violation (above and below limit) – Fault alarm output: indicates existing error messages with 'Failure' status classification and condensed state according to 'Error message in case of ... condensed state' message.

Menu	Display reading	On-site: write	Diagnostics	Adjustment range/values [default setting]/description
Mode	8.10.23.21	•	•	→ [Below limit], Above limit Determines whether the software limit switch is to be activated when the value exceeds or falls below the adjusted limit. Note: Parameter only active when 'Function' = 'Software limit switch'
Edge control	8.10.23.22	•	•	→ [Conducting/high], Non-conducting/low Determines in which state the software limit switch is active. Note: Parameter only active when 'Function' = 'Software limit switch'
Error message in case of 'Function check' condensed state	–	–	•	→ [Yes], No Activate/deactivate the error message in case of 'Function check' condensed state Note: Parameter only active when 'Function' = 'Fault alarm output'
Error message in case of 'Maintenance required' and 'Out of specification' condensed states	–	–	•	→ [Yes], No Activate/deactivate the error message in case of 'Maintenance required' or 'Out of specification' condensed state Note: Parameter only active when 'Function' = 'Fault alarm output'
Limit	8.10.23.25	•	•	→ -20.0 to 120.0 % [2.0 %] Determines the limit for the response of the software limit switch Note: Parameter only active when 'Function' = 'Fault alarm output'
Current state	8.10.23.26	•	•	Indicates the status of the software limit switch or fault alarm output.
Start DO test.	8.10.23.27	•	•	→ Confirm to start the function test of the software limit switch or fault alarm output.
Test mode	8.10.23.28	•	•	Indicates the DO test status (function test of the software limit switch or fault alarm output).
Limit switch 3	8.10.24	•	•	
Terminal designation	8.10.24.1	•	•	Indicates the terminals for electrical connection of limit switches option (see the 'Installation' chapter).
Function	8.10.24.20	•	•	→ [Software limit switch], Fault alarm output Select the function: – Software limit switch: Indicates limit violation (above and below limit) – Fault alarm output: indicates existing error messages with 'Failure' status classification and condensed state according to 'Error message in case of ... condensed state' message.

Appendix A (configuration instructions)

Menu	Display reading	On-site: write	Diagnostics	Adjustment range/values [default setting]/description
Mode	8.10.24.21	•	•	→ [Below limit], Above limit Determines whether the software limit switch is to be activated when the value exceeds or falls below the adjusted limit. Note: Parameter only active when 'Function' = 'Software limit switch'
Edge control	8.10.24.22	•	•	→ [Conducting/high], Non-conducting/low Determines in which state the software limit switch is active. Note: Parameter only active when 'Function' = 'Software limit switch'
Error message in case of 'Function check' condensed state	–	–	•	→ [Yes], No Activate/deactivate the error message in case of 'Function check' condensed state Note: Parameter only active when 'Function' = 'Fault alarm output'
Error message in case of 'Maintenance required' and 'Out of specification' condensed states	–	–	•	→ [Yes], No Activate/deactivate the error message in case of 'Maintenance required' or 'Out of specification' condensed state Note: Parameter only active when 'Function' = 'Fault alarm output'
Limit	8.10.24.25	•	•	→ -20.0 to 120.0 % [2.0 %] Determines the limit for the response of the software limit switch Note: Parameter only active when 'Function' = 'Fault alarm output'
Current state	8.10.24.26	•	•	Software limit switch or fault alarm output
Start DO test.	8.10.24.27	•	•	→ Confirm to start the function test of the software limit switch or fault alarm output.
Test mode	8.10.24.28	•	•	Indicates the DO test status (function test of the software limit switch or fault alarm output).
Select test	8.10.24.30	•	•	→ Full stroke test (FST), [Partial stroke test (PST)], Dead band, Valve signature IP, Valve signature Select which test results are shown in the 'Test result' parameter.
Test result	8.10.24.30	•	•	Test result of the test selected in the 'Select test' parameter.
External position sensor status	8.10.38	•	•	Indicates the status of the external position sensor. The external position sensor is functional when 'External position sensor status' = 'Option active'
Position sensor	8.10.40	•	•	
Terminal designation	8.10.40.1	•	•	Indicates the terminals for electrical connection of the external position sensor (see the 'Installation' chapter).

Menu	Display reading	On-site: write	Diagnostics	Adjustment range/values [default setting]/description
External position sensor signal (scaled and filtered)	8.10.40.41	•	•	Reading of the signal in % (based on 4 to 20 mA) measured by the external position sensor
Power line frequency filter	8.10.40.43	•	•	→ No filter, [50 Hz filter], 60 Hz filter Activate/deactivate the software filter to suppress measuring signal interference
Valve position	8.10.40.46	•	•	Indicates the current position of the external position sensor in degrees
Mid-position of external position sensor	8.10.40.47	•	•	Indicates the mid-position of the external position sensor in degrees
External position sensor ID	8.10.40.50	•	•	→ [Track], AMR Determines whether a track or an AMR sensor is used as the external position sensor.
Pressure sensors	8.10.46	•	•	
Pressure sensors active	8.10.46.1	•	•	→ Yes, [No] Indicates whether the positioner has pressure sensors or not.
OUTPUT 38: pressure	8.10.46.2	•	•	Pressure in bar at the positioner's output 38 Note: Only when 'Pressure sensors exist' = 'Yes'
Supply pressure	8.10.46.4	•	•	Supply pressure in bar at the input (supply 9) Note: Only when 'Pressure sensors exist' = 'Yes'
Pressure sensors installed	8.10.46.10	•	•	Indicates whether pressure sensors exist in the positioner.
Humidity sensor	–	–	•	
Air humidity	–	–	•	Indicates the air humidity measured in the positioner in %.
HART® communication	8.20	•	•	
HART communication locked	8.20.1	•	•	→ Yes, [No] Lock or unlock HART® communication
Fixed value (communication)	8.20.3	•	•	Indicates whether the fixed value transmitted over H is active or inactive.
Fixed value (communication)	8.20.4	•	•	Reading of the fixed value in % transmitted over HART® communication
Polling address	8.20.7	•	•	→ [0] to 63 Polling address for HART® communication

Appendix A (configuration instructions)

Menu	Display reading	On-site: write	Diagnostics	Adjustment range/values [default setting]/description
Loop current value	8.20.8	•	•	→ 0, [1] Value for loop current (HART® communication) Note: The loop current always corresponds to the current that can be measured using an ammeter in series with the field device. It includes the loop current under alarm conditions.
Tag no.	8.20.12	•	•	Text box to enter description (8 characters)
Tag no. (long)	8.20.15	•	•	Text box to enter description (32 characters)
Preambles	8.20.18	•	•	→ [5] to 20 Number of preambles
Find device flag	8.20.21	•	•	→ Yes, [No] The positioner only responds to the Device Flag' command (HART® communication) if 'Find Device Flag' = 'Yes'.
Final assembly number	8.20.24	•	•	→ 0 to 16777215 Final assembly number is used to identify the materials and electronics in the positioner.
Primary variable assignment	–	–	•	→ [Set point at the input], Valve position, Set point deviation, Condensed state, Slot C.1: binary input, Slot D.1: binary input, Slot C.2: binary input, Slot D.2: binary input, Slot C.3: binary input, Slot D.3: binary input, Total valve travel, Current temperature, Results of PST, Results of FST, Discrete valve pos. Selects which parameter value is to be transmitted as the primary variable over HART® communication.
Secondary variable assignment	–	–	•	→ Set point at the input, [Valve position], Set point deviation, Condensed state, Slot C.1: binary input, Slot D.1: binary input, Slot C.2: binary input, Slot D.2: binary input, Slot C.3: binary input, Slot D.3: binary input, Total valve travel, Current temperature, Results of PST, Results of FST, Discrete valve pos. Selects which parameter value is to be transmitted as the secondary variable over HART® communication.
Tertiary variable assignment	–	–	•	→ Set point at the input, Valve position, [Set point deviation], Condensed state, Slot C.1: binary input, Slot D.1: binary input, Slot C.2: binary input, Slot D.2: binary input, Slot C.3: binary input, Slot D.3: binary input, Total valve travel, Current temperature, Results of PST, Results of FST, Discrete valve pos. Selects which parameter value is to be transmitted as the tertiary variable over HART® communication.

Menu	Display reading	On-site: write	Diagnostics	Adjustment range/values [default setting]/description
Quaternary variable assignment	–	–	•	<p>➔ Set point at the input, Valve position, Set point deviation, [Condensed state], Slot C.1: binary input, Slot D.1: binary input, Slot C.2: binary input, Slot D.2: binary input, Slot C.3: binary input, Slot D.3: binary input, Total valve travel, Current temperature, Results of PST, Results of FST, Discrete valve pos.</p> <p>Selects which parameter value is to be transmitted as the quaternary variable over HART® communication.</p>
Device Status Master	–	–	•	Indicates the device status of the device (positioner) defined as master.
Loop Current Fixed Bit	–	–	•	Indicates whether the loop current is kept at a fixed value and does not respond to the process variables.
More Status Available Bit	–	–	•	Indicates whether additional status information is available.
Cold Start Bit	–	–	•	Indicates whether the positioner has been restarted since the last HART® telegram.
Configuration Changed Bit	–	–	•	Indicates whether the configuration of the positioner has changed since the last HART® telegram.
Device Malfunction Bit	–	–	•	Indicates whether a positioner malfunction exists.

16.1.3 Process data

Menu	Display reading	On-site: write	Diagnostics	Adjustment range/values [default setting]/description
Process data	10	•	•	
Valve position	10.1	•	•	Reading of valve position in %
Valve position	10.2	•	•	Reading of valve position in degrees
Set point	10.10	•	•	Reading of set point in %
Set point	–	–	•	Reading of set point in mA
Manual set point (MAN)	10.11	•	•	Reading of set point for manual mode (MAN) in %
Set point after filter	10.13	•	•	Reading of adjusted set point after set point processing (split range, tight-closing function etc.)
Discrete valve position	–	–	•	Reading of discrete valve position (OPEN, CLOSED, intermediate position)

Appendix A (configuration instructions)

Menu	Display reading	On-site: write	Diagnostics	Adjustment range/values [default setting]/description
Fixed value (communication)	10.14	–	•	Reading of the fixed value transmitted over HART® communication
Fixed value (communication)	10.15	–	•	Indicates whether the fixed value transmitted over H is active or inactive.
Fixed value over binary input	10.16	–	•	Reading of the valve position (%) that the valve is to move to when the binary input is active.
Fixed value over binary input	10.17	–	•	Indicates whether the binary input is active or inactive.
Set point deviation	10.30	•	•	Reading of set point deviation in %
Current operating mode	10.35	•	•	Indicates current operating mode
Reason for fail-safe position	10.38	•	•	Reason why the positioner has moved to the fail-safe position.
OUTPUT 38: pressure	10.45	•	•	Pressure reading in bar at the positioner's output 38
Supply pressure	10.47	•	•	Reading of supply pressure in bar at the input (supply 9)
Temperature inside device	10.55	•	•	Reading of the temperature inside device in °C
Air humidity	10.60	•	•	Indicates the air humidity in the positioner in %.

16.1.4 Diagnosis/maintenance

Menu	Display reading	On-site: write	Diagnostics	Adjustment range/values [default setting]/description
Diagnosis/maintenance	12	•	•	
Configuration	12.1	•	•	
Lower press. limit	–	–	•	→ 0.10 to 10.00 bar [1.40 bar] Enter the limit for the 'Low supply pressure' status message. The value is automatically adapted during the recording of the valve signature. It can be changed afterwards. Note: Only positioners with pressure sensors.
Stem seal	–	–	•	→ Self-adjusting, Adjustable, Bellows, Other, [Not selected] Indicates the stem seal used in the valve. This parameter is important to evaluate the total valve travel (Monitoring).
Total valve travel limit x 1000	12.1.20	•	•	→ 1 to 90000 * 1000 [1000 * 1000] The 'Total valve travel' status message is generated when the total valve travel exceeds the limit.

Menu	Display reading	On-site: write	Diagnostics	Adjustment range/values [default setting]/description
Lag time for set point deviation	12.1.30	•	•	→ 1 to 65535 s [30 s] The lag time is determined during initialization. It is the criterion to generate the 'Set point deviation' status message.
Tolerance band for set point deviation +/-	12.1.31	•	•	→ 0.1 to 10.0 % [5.0 %] Used for error monitoring. A set point deviation is recognized as a system deviation when the valve position deviates from the set point by the value adjusted in this parameter.
Log 'No message' (NAMUR classification)	–	–	•	→ [Yes], No Select whether all status messages (including 'No message' status) are logged or not.
Status classification	–	–	•	See the 'Malfunction' chapter for details.
Condensed state	–	–	•	[Highest classification]
Start-up	–	–	•	[Highest classification]
Initialization	–	–	•	[Highest classification]
Init: incorrect operating mode	–	–	•	[No message]
Init: travel too small	–	–	•	[Maintenance required]
Init: rated travel not achieved	–	–	•	[Maintenance required]
Init: no movement	–	–	•	[Maintenance required]
Init: pin position	–	–	•	[Maintenance required]
Init: canceled (control accuracy)	–	–	•	[Highest classification]
Init: low control accuracy	–	–	•	[Highest classification]
Positioner not initialized	–	–	•	[Out of specification]
Init: canceled externally	–	–	•	[Maintenance required]
Init: angle limitation	–	–	•	[Highest classification]
Init: timeout	–	–	•	[Highest classification]
Zero calibration error	–	–	•	[Highest classification]
Timeout for detection of zero	–	–	•	[Maintenance required]
Zero calibration: shift >>	–	–	•	[Maintenance required]

→ No message, Maintenance required, Out of specification, Function check, Failure, Highest classification

Further details can be found in ► EB 8389-3.

Appendix A (configuration instructions)

Menu	Display reading	On-site: write	Diagnostics	Adjustment range/values [default setting]/description
Configuration	–	–	•	[Highest classification]
Pressure sensors failed				[Maintenance required]
Combination of options invalid	–	–	•	[Maintenance required]
Forced venting switch incorrect	–	–	•	Parameter without function
Binary input option A active	–	–	•	[No message]
Binary input option B active	–	–	•	[No message]
External position sensor error	–	–	•	[Maintenance required]
Process data	–	–	•	[Highest classification]
Operating mode not AUTO	–	–	•	[No message]
Forced venting function	–	–	•	[Failure]
Test in progress	–	–	•	[Function check]
Emergency mode active	–	–	•	[Maintenance required]
Control valve diagnosis	–	–	•	[Highest classification]
No supply pressure	–	–	•	[Out of specification]
Low supply pressure	–	–	•	[Maintenance required]
Supply pressure > 7 bar	–	–	•	[Out of specification]
Friction change (open pos.)	–	–	•	[No message]
Friction change (mid-pos.)	–	–	•	[No message]
Friction change (closed pos.)	–	–	•	[No message]
Valve signature failed	–	–	•	[Maintenance required]
Spring possibly broken	–	–	•	[Maintenance required]
Broken spring detected	–	–	•	[Maintenance required]

→ No message, Maintenance required, Out of specification, Function check, Failure, Highest classification

Further details can be found in ► EB 8389-3.

Menu	Display reading	On-site: write	Diagnostics	Adjustment range/values [default setting]/description
Pneumatic leakage	-	-	•	[Highest classification]
PST	-	-	•	[Highest classification]
PST: start criteria not met	-	-	•	[No message]
PST: cancellation criteria met	-	-	•	[Maintenance required]
FST	-	-	•	[Highest classification]
FST: start criteria not met	-	-	•	[No message]
FST: cancellation criteria met	-	-	•	[Maintenance required]
AMR signal outside range	-	-	•	[Maintenance required]
Hardware fault	-	-	•	[Highest classification]
Limit for total valve travel exceeded	-	-	•	[Maintenance required]
Lower end position shifted	-	-	•	[Maintenance required]
Upper end position shifted	-	-	•	[Maintenance required]
Dynamic stress factor exceeded	-	-	•	[Maintenance required]
Set point deviation	-	-	•	[Maintenance required]
Brownout	-	-	•	[Maintenance required]
Current too low	-	-	•	[Out of specification]
IP shutdown	-	-	•	[No message]
Current too high	-	-	•	[Out of specification]
Angle limitation	-	-	•	[Highest classification]
Temperature inside device below min. limit	-	-	•	[Out of specification]
Temperature inside device above max. limit	-	-	•	[Out of specification]
Logging suspended	-	-	•	[Maintenance required]
Operating range in CLOSED position	-	-	•	[No message]
Operating range in max. OPEN position	-	-	•	[No message]

→ No message, Maintenance required, Out of specification, Function check, Failure, Highest classification
 Further details can be found in ► EB 8389-3.

Appendix A (configuration instructions)

Menu	Display reading	On-site: write	Diagnostics	Adjustment range/values [default setting]/description
Operating range shifting towards CLOSED position	–	–	•	[No message]
Operating range shifting towards max. OPEN position	–	–	•	[No message]
Limited working range: lower range	–	–	•	[No message]
Limited working range: upper range	–	–	•	[No message]
Device state	12.3	•	•	
Status messages	12.3.2	•	•	Messages which may be displayed: see Chapter 16.1.5
Logging	–	–	•	
OUTPUT 38: pressure	12.3.16	•	•	Pressure reading in bar at the positioner's output 38
Supply pressure	12.3.18	•	•	Reading of supply pressure in bar at the input (supply 9)
Min. supply pressure	–	–	•	Reading of the lowest measured supply pressure
Time stamp of min. supply pressure	–	–	•	Time when the lowest measured supply pressure occurred.
Max. supply pressure	–	–	•	Reading of the highest measured supply pressure
Time stamp of max. supply pressure	–	–	•	Time when the highest measured supply pressure occurred.
Dynamic stress factor	–	–	•	Indicates the stress of the bellows and/or packing.
Total valve travel	12.3.40	•	•	Totaled full valve travel cycle
Temperature inside device	–	–	•	Reading of the temperature inside the positioner
Min. temperature inside device	12.3.52	•	•	Reading in °C For error monitoring after the temperature falls below the permissible ambient temperatures. Note: This parameter can be found in the [Temperature] folder in the 'Diagnosis' user level.
Max. temperature inside device	12.3.50	•	•	Reading in °C For error monitoring after the temperature exceeds the permissible ambient temperatures. Note: This parameter can be found in the [Temperature] folder in the 'Diagnosis' user level.
Min. temperature limit	–	–	•	Enter the temperature limit for the 'Min. temperature limit' status message. Note: This parameter can be found in the [Temperature] folder.

→ No message, Maintenance required, Out of specification, Function check, Failure, Highest classification

Further details can be found in
▶ EB 8389-3.

Menu	Display reading	On-site: write	Diagnostics	Adjustment range/values [default setting]/description
Max. temperature limit	–	–	•	Enter the temperature limit for the 'Max. temperature limit' status message. Note: This parameter can be found in the [Temperature] folder.
Air humidity	–	–	•	Indicates the air humidity in the positioner.
Min. air humidity	–	–	•	Reading of the lowest measured air humidity
Time stamp of min. air humidity	–	–	•	Time when the lowest measured air humidity occurred.
Temperature	–	–	•	Temperature at the time when the lowest air humidity was measured
Housing pressure	–	–	•	Housing pressure at the time when the lowest air humidity was measured
Air humidity	–	–	•	Reading of the highest measured air humidity
Max. air humidity	–	–	•	Time when the highest measured air humidity occurred.
Time stamp of max. air humidity	–	–	•	Temperature at the time when the highest air humidity was measured
Temperature	–	–	•	Housing pressure at the time when the highest air humidity was measured
Housing pressure	–	–	•	Pressure inside the positioner
Operating hours counter	12.3.60	•	•	Reading in d:hh:mm:ss
Device switched on since initialization	–	–	•	Indicates how long the positioner has been switched on since the last initialization.
Device in closed-loop operation	–	–	•	Indicates how long the positioner has been in closed-loop operation.
Device in closed-loop operation since last initialization	–	–	•	Indicates how long the positioner has been in closed-loop operation since the last initialization.
Number of initializations	12.3.65	•	•	Number of successfully completed valve initializations
Number of zero calibrations	12.3.66	•	•	Number of performed zero calibrations
Diagnostic data				→ Confirm to save the diagnostic data.
Monitoring	12.5	•	•	
Histograms				
Reset histograms	–	–	•	→ Confirm to reset all histograms.
Valve position	–	–	•	→ Open folder to view the histogram. Details in the Operating Instructions for valve diagnostics ► EB 8389-3
Set point deviation	–	–	•	→ Open folder to view the histogram. Details in the Operating Instructions for valve diagnostics ► EB 8389-3

Appendix A (configuration instructions)

Menu	Display reading	On-site: write	Diagnostics	Adjustment range/values [default setting]/description
Load cycle	–	–	•	→ Open folder to view the histogram. Details in the Operating Instructions for valve diagnostics ► EB 8389-3
Course of end position	–	–	•	
Threshold for end position shift	–	–	•	→ 0.3 to 100.0 % [5.0 %] Enter the limit by how much the lower end position must change to generate the 'Course of lower end position' and 'Course of upper end position' status messages.
Course of lower end position	–	–	•	
Time stamp	–	–	•	Time reading when the course of lower end position was recorded.
Temperature	–	–	•	Reading of the temperature inside the positioner while the course of lower end position was being recorded.
Course of upper end position	–	–	•	
Time stamp	–	–	•	Time reading when the course of upper end position was recorded.
Temperature	–	–	•	Reading of the temperature inside the positioner while the course of upper end position was being recorded.
Course of supply pressure	–	–	•	Note: Data are only shown for positioners with pressure sensors.
New recording threshold for supply pressure	–	–	•	→ 0.10 to 5.00 bar [1.00 bar] Enter the limit by how much the supply pressure must change to start recording the course of the supply pressure.
Time stamp	–	–	•	Reading of the time when the course of the supply pressure was recorded during the last initialization
Supply pressure	–	–	•	Reading of the supply pressure recorded during the last initialization
Reset course of supply pressure	–	–	•	→ Confirm to reset the course of supply pressure.
Valve signature	12.5.6	•	•	Note: Only positioners with pressure sensors
Start recording of reference graphs	12.5.6.1	•	•	→ Confirm to start recording of reference graphs.
Stop test	–	•	•	→ Confirm to stop recording of reference graphs.
Valve signature status	–	–	•	Indicates whether the valve signature is valid or not.
Monitoring	–	–	•	→ Open folder to view the graph. Details in the Operating Instructions for valve diagnostics ► EB 8389-3

Menu	Display reading	On-site: write	Diagnostics	Adjustment range/values [default setting]/description
Friction	–	–	•	→ Open folder to view the graph. Details in the Operating Instructions for valve diagnostics ► EB 8389-3
Result of last valve signature	12.5.6.4	•	•	→ Confirm to read the status of the last valve signature.
Time stamp	–	–	•	Time reading when the reference was recorded.
Lower bench range value	–	–	•	Reading of the signal pressure p_{out} at minimum supply
Upper bench range value	–	–	•	Reading of the signal pressure p_{out} at maximum supply
Min. hysteresis	–	–	•	Reading of the lowest possible hysteresis (minimum signal pressure difference in relation to the bench range)
Max. hysteresis	–	–	•	Reading of the highest possible hysteresis (maximum signal pressure difference in relation to the bench range)
Average hysteresis	–	–	•	Reading of the average hysteresis (average signal pressure difference in relation to the bench range)
Reset monitoring values	–	–	•	→ Confirm to reset the monitoring values.
Test functions	12.8	•	•	
Partial stroke test (PST)	12.8.1	•	•	
Start PST	12.8.1.1	•	•	→ Confirm to start the test.
Stop test	–	•	•	→ Confirm to stop the test.
Time until next test	–	–	•	Indicates how long until the next time-controlled PST starts.
Result or Result of last test ¹⁾	12.8.1.5	•	•	→ Confirm to read the status of the last partial stroke test (PST).
Test status	12.8.1.6	•	•	Indicates whether the test is active or inactive.
Number of successful tests	–	–	•	Indicates the number of successfully performed tests since the last test reset.
Number of canceled tests	–	–	•	Indicates the number of canceled tests since the last test reset.
Number of failed test criteria	–	–	•	Indicates the number of failed start criteria. The start criteria are determined in the 'Configuration' folder.
Canceled: x monitoring	12.8.1.10	•	•	Reading in %. Canceled when range is violated. Note: This parameter can be found in the 'Configuration' folder in the 'Diagnosis' user level.
Configuration	–	–	•	Details in the Operating Instructions for valve diagnostics ► EB 8389-3
Reports and graphs	–	–	•	Details in the Operating Instructions for valve diagnostics ► EB 8389-3

Appendix A (configuration instructions)

Menu	Display reading	On-site: write	Diagnostics	Adjustment range/values [default setting]/description
Full stroke test (FST)	12.8.2			
Start FST	112.8.2.1	•	•	➔ Confirm to start the test.
Stop test	–	•	•	➔ Confirm to stop the test.
Result or Result of last test ¹⁾	12.8.2.5	•	•	➔ Confirm to read the status of the last full stroke test (FST).
Test status	12.8.2.6	•	•	Indicates whether the test is active or inactive.
Number of successful tests	–	–	•	Indicates the number of successfully performed tests since the last test reset.
Number of canceled tests	–	–	•	Indicates the number of canceled tests since the last test reset.
Number of failed test criteria	–	–	•	Indicates the number of failed start criteria. The start criteria are determined in the 'Configuration' folder.
Configuration	–	–	•	Details in the Operating Instructions for valve diagnostics ▶ EB 8389-3
Reports and graphs	–	–	•	Details in the Operating Instructions for valve diagnostics ▶ EB 8389-3
Dead band	12.8.3			
Start dead band test	12.8.3.1	•	•	➔ Confirm to start the test.
Stop test	–	•	•	➔ Confirm to stop the test.
Result or Result of last test ¹⁾	12.8.3.5	•	•	➔ Confirm to read the status of the last dead band test.
Test status	–	–	•	Indicates whether the test is active or inactive.
Configuration	–	–	•	Details in the Operating Instructions for valve diagnostics ▶ EB 8389-3
Reports and graphs	–	–	•	Details in the Operating Instructions for valve diagnostics ▶ EB 8389-3
Valve signature IP	12.8.5.1			Note: Only positioners without pressure sensors
Start repetition test	12.8.5.1	•	•	➔ Confirm to start the test.
Stop test	–	•	•	➔ Confirm to stop the test.
Result or Result of last valve signature ¹⁾	–	•	•	➔ Confirm to read the status of the repetition test (valve signature).
Valve signature status	–	–	•	Indicates whether the valve signature is valid or not.
Reports and graphs	–	–	•	Details in the Operating Instructions for valve diagnostics ▶ EB 8389-3
Valve signature	12.8.4			Note: Only positioners with pressure sensors
Start repetition test	12.8.4.1	•	•	➔ Confirm to start the test.
Stop test	–	•	•	➔ Confirm to stop the test.

Menu	Display reading	On-site: write	Diagnostics	Adjustment range/values [default setting]/description
Result or Result of last valve signature ¹⁾	12.8.4.5	•	•	→ Confirm to read the status of the repetition test (valve signature).
Valve signature status	–	–	•	Indicates whether the valve signature is valid or not.
Reports and graphs	–	–	•	Details in the Operating Instructions for valve diagnostics ▶ EB 8389-3

16.1.5 Diagnosis: status messages

Active status messages are also shown in the start screen (display/numbering: 0.50). See Chapter 16.1. See the 'Malfunctions' chapter for information on troubleshooting.

Menu	Display reading	On-site: write	Diagnostics	Adjustment range/values [default setting]/description
Diagnosis/maintenance	12	•	•	
Device state	12.3	•	•	
Status messages	12.3.2	•	•	
Condensed state	12.3.2.1	•	•	Status indicators
Start-up	12.3.2.2	–	•	Status indicators
Initialization error	12.3.2.3	• ¹⁾	•	Status indicators
Incorrect operating mode or Init: incorrect operating mode ²⁾	12.3.2.4	• ¹⁾	•	The incorrect operating mode is set.
	12.3.2.5	• ¹⁾	–	→ Confirm to clear message.
Travel too small or Init: travel too small ²⁾	12.3.2.6	• ¹⁾	•	The determined travel is below the limit.
	12.3.2.7	• ¹⁾	–	Confirm to clear message.
Rated travel not achieved or Init: rated travel not achieved ²⁾	12.3.2.8	• ¹⁾	•	The detected rated travel is smaller than the value in the setting.
	12.3.2.9	• ¹⁾	–	→ Confirm to clear message.
No movement or Init: no movement ²⁾	12.3.2.10	• ¹⁾	•	Possible cause: valve blockage.
	12.3.2.11	• ¹⁾	–	→ Confirm to clear message.
Pin position or Init: pin position ²⁾	12.3.2.12	• ¹⁾	•	The adjusted lever M does not match the rated travel.
	12.3.2.13	• ¹⁾	–	→ Confirm to clear message.

Appendix A (configuration instructions)

Menu	Display reading	On-site: write	Diagnostics	Adjustment range/values [default setting]/description
Canceled (control accuracy) or Init: canceled (control accuracy) ²⁾	12.3.2.14	• ¹⁾	•	Control criteria are not fulfilled.
	12.3.2.15	• ¹⁾	–	→ Confirm to clear message.
Oscillation or Init: oscillation	12.3.2.16	• ¹⁾	•	Control criteria are not fulfilled.
	12.3.2.17	• ¹⁾	–	→ Confirm to clear message.
End position not reached or Init: end position not reached	12.3.2.18	• ¹⁾	•	The valve was unable to move through the travel range required for initialization.
	12.3.2.19	• ¹⁾	–	→ Confirm to clear message.
Low control accuracy or Init: low control accuracy ²⁾	12.3.2.20	• ¹⁾	•	Control criteria are not fulfilled. Closed-loop control is possible with restrictions.
	12.3.2.21	• ¹⁾	–	→ Confirm to clear message.
Positioner not initialized or Init: positioner not initialized ²⁾	12.3.2.22	• ¹⁾	•	The positioner needs to be initialized.
Initialization canceled (external) or Init: canceled externally ²⁾	12.3.2.23	• ¹⁾	•	Initialization was canceled, e.g. due to forced venting or IP shutdown.
	12.3.2.24	• ¹⁾	–	→ Confirm to clear message.
Angle limitation or Init: angle limitation ²⁾	12.3.2.25	• ¹⁾	•	The maximum permissible angle of rotation ($\pm 30^\circ$) has been exceeded.
	12.3.2.26	• ¹⁾	–	→ Confirm to clear message.
Timeout or Init: timeout ²⁾	12.3.2.27	• ¹⁾	•	Initialization takes too long. Possible cause: valve blockage.
	12.3.2.28	• ¹⁾	–	→ Confirm to clear message.
Zero calibration error	12.3.2.29	• ¹⁾	•	Initialization takes too long. Possible cause: valve blockage.
Timeout for detection of zero	12.3.2.30	• ¹⁾	•	Zero calibration takes too long. Possible cause: no supply pressure or actuator/plug stem blocked.
	12.3.2.31	• ¹⁾	–	→ Confirm to clear message.
Zero calibration: shift >>	12.3.2.32	• ¹⁾	•	Zero has shifted. Possible cause: wear at the seat and plug.
Configuration	12.3.2.33	• ¹⁾	•	Status indicators
Pressure sensors failed	12.3.2.34	• ¹⁾	•	Pressure sensor failure Possible cause: no supply pressure or no input signal

Menu	Display reading	On-site: write	Diagnostics	Adjustment range/values [default setting]/description
Combination of options or Combination of options invalid ²⁾	12.3.2.35	• ¹⁾	•	Impermissible combination of pneumatic modules (see the 'Start-up and configuration' chapter)
Forced venting switch incorrect	12.3.2.36	• ¹⁾	•	Parameter without function
Binary input option A active	12.3.2.37	• ¹⁾	•	State is active.
Binary input option B active	12.3.2.38	• ¹⁾	•	State is active.
External position sensor error	12.3.2.39	• ¹⁾	•	Status indicators
Process data	12.3.2.40	• ¹⁾	•	Status indicators
Operating mode not AUTO	12.3.2.41	• ¹⁾	•	Current operating mode is not AUTO.
Forced venting function	12.3.2.42	• ¹⁾	•	The forced venting is active.
Test in progress	12.3.2.43	• ¹⁾	•	A test is being performed.
Emergency mode active	12.3.2.44	• ¹⁾	•	Emergency mode is active. Possible cause: travel measurement does not function properly.
Control valve diagnosis	12.3.2.45	• ¹⁾	•	Status indicators
No supply pressure	12.3.2.46	• ¹⁾	•	No supply pressure is available.
Low supply pressure	12.3.2.47	• ¹⁾	•	Supply pressure is lower than the required supply pressure (see the 'Supply pressure' chapter).
Supply pressure > 7 bar	12.3.2.48	• ¹⁾	•	Supply pressure is greater than 7 bar.
Friction change (open pos.)	12.3.2.49	• ¹⁾	•	The friction conditions in the range of the valve's open position have changed.
Friction change (mid-position)	12.3.2.50	• ¹⁾	•	The friction conditions in the range of the valve's mid-position have changed.
Friction change (closed pos.)	12.3.2.51	• ¹⁾	•	The friction conditions in the range of the valve's closed position have changed.
Valve signature failed	12.3.2.52	• ¹⁾	•	Conditions for a completed valve signature not fulfilled.
Spring possibly broken	12.3.2.53	• ¹⁾	•	A spring in the actuator may be broken.
Broken spring detected	12.3.2.54	• ¹⁾	•	Spring in the actuator broken

Appendix A (configuration instructions)

Menu	Display reading	On-site: write	Diagnostics	Adjustment range/values [default setting]/description
Pneumatic leakage	12.3.2.55	• ¹⁾	•	Leakage in the pneumatics exists.
PST	12.3.2.56	• ¹⁾	•	Status indicators
PST: cancellation criteria met	12.3.2.57	• ¹⁾	•	Partial stroke test (PST) canceled.
PST: start criteria not met	12.3.2.58	• ¹⁾	•	Partial stroke test (PST) did not start.
FST	12.3.2.59	• ¹⁾	•	Status indicators
FST: cancellation criteria met	12.3.2.60	• ¹⁾	•	FST (full stroke test) canceled.
FST: start criteria not met	12.3.2.61	• ¹⁾	•	Full stroke test (FST) did not start.
AMR signal outside range	12.3.2.62	• ¹⁾	•	Travel measurement is defective.
	12.3.2.63	• ¹⁾	•	➔ Confirm to clear message.
Hardware fault	12.3.2.64	• ¹⁾	•	Internal device error. Initialization key (INIT) jammed. Contact SAMSON's After-sales Service Department.
Limit for total valve travel exceeded	12.3.2.65	• ¹⁾	•	Limit for total valve travel [12.1.20] exceeded.
Lower end position shifted	12.3.2.66	• ¹⁾	•	Possible cause: mounting arrangement or travel linkage of positioner has slipped.
	12.3.2.67	• ¹⁾	•	➔ Confirm to clear message.
Upper end position shifted	12.3.2.68	• ¹⁾	•	Possible cause: mounting arrangement or travel linkage of positioner has slipped.
	12.3.2.69	• ¹⁾	•	➔ Confirm to clear message.
Dynamic stress factor exceeded or Dynamic stress factor active ²⁾	12.3.2.70	• ¹⁾	•	The limit is exceeded. It may be necessary to change the valve packing.
Set point deviation	12.3.2.71	• ¹⁾	•	Control loop error, the valve no longer follows the controlled variable within tolerable times.
Brownout	12.3.2.72	• ¹⁾	•	Brief power failure. The positioner remains ready for use.
	12.3.2.73	• ¹⁾	•	➔ Confirm to clear message.
Current too low (w < 3.7 mA)	12.3.2.74	• ¹⁾	•	Current for operating the positioner too low (set point <3.7 mA).
IP shutdown (w < 3.85 mA)	12.3.2.75	• ¹⁾	•	Set point <3.85 mA
Current too high (w > 22 mA)	12.3.2.76	• ¹⁾	•	Forced venting function/fail-safe position triggered by set point (>22 mA). The positioner remains ready for use.

Menu	Display reading	On-site: write	Diagnostics	Adjustment range/values [default setting]/description
Temperature inside device below min. limit	12.3.2.77	• ¹⁾	•	Warning not affecting the positioner's functioning.
Temperature inside device above max. limit	12.3.2.78	• ¹⁾	•	Warning not affecting the positioner's functioning.
Angle limitation	12.3.2.79	• ¹⁾	•	The maximum permissible angle of rotation ($\pm 30^\circ$) has been exceeded (only in open-loop control mode).
	12.3.2.80	• ¹⁾	•	→ Confirm to clear message.
Logging suspended	12.3.2.81	• ¹⁾	•	It was not possible to write all logging entries.
	12.3.2.82	• ¹⁾	•	→ Confirm to clear message.
Operating range in CLOSED position	12.3.2.83	• ¹⁾	•	The valve remains in the closed position. Possible cause: no supply pressure or actuator/plug stem blocked.
Operating range in max. OPEN position	12.3.2.84	• ¹⁾	•	The valve remains in the max. OPEN position. Possible cause: no supply pressure or actuator/plug stem blocked.
Operating range shifting towards CLOSED position	12.3.2.85	• ¹⁾	•	The operating range has shifted towards the CLOSED position. Possible cause: valve sized incorrectly.
Operating range shifting towards max. OPEN position	12.3.2.86	• ¹⁾	•	The operating range has shifted towards the max. OPEN position. Possible cause: valve sized incorrectly.
Limited working range: lower range	12.3.2.87	• ¹⁾	•	The valve position is restricted to the lower working range. Possible cause: no supply pressure or actuator/plug stem blocked.
Limited working range: upper range	12.3.2.88	• ¹⁾	•	The valve position is restricted to the upper working range. Possible cause: no supply pressure or actuator/plug stem blocked.

¹⁾ Reading only when active

²⁾ Different designations used in the SAMSON TROVIS-VIEW software and DD/DTM/EDD.

16.1.6 Reset functions

Menu	Display reading	On-site: write	Diagnostics	Adjustment range/values [default setting]/description
Reset functions	14	•	•	
Reset diagnosis	14.1	•	•	Resets all diagnostic functions including graphs and histograms.
Reset (standard)	14.2	•	•	Resets the positioner to the state as upon delivery. Actuator and valve-specific settings remain unchanged.
Reset (advanced)	14.3	•	•	All parameters will be reset to their defaults adjusted upon delivery.
Restart	14.6	•	•	The positioner is shut down and restarted.
Reset in progress	–	–	•	Indicates whether the reset function is active or not.
Reset reports	14.10	•	–	
Delete PST reports	–	•	•	The reports and graphs of all saved partial stroke tests are deleted.
Delete FST reports	–	–	•	The reports and graphs of all saved full stroke tests are deleted.
Reset dead band data	–	–	•	The reports, measured data and graphs for the dead band test are deleted.
Reset course of end position	–	–	•	The measured data of the course of the lower and upper end positions are deleted.
Reset histograms	–	–	•	The measured data and archived data of the histograms (valve position, set point deviation and load cycle) are deleted.
Reset initialization	14.15	•	•	All parameters for the start-up settings are reset. The positioner needs to be re-initialized afterwards.
Reset logging	–	–	•	Logged events, alarms and alerts are deleted.
Reset monitoring values	–	–	•	The measured data recorded for the valve signature (Monitoring) are deleted.
Reset course of supply pressure	–	–	•	The measured data for the course of the supply pressure are reset.

16.1.7 Display start-up

Menu	Display reading	On-site: write	Diagnostics	Adjustment range/values [default setting]/description
Display start-up	16	–	–	
Reading direction	16.1	–	–	→ [Pneumatics (right)]/Pneumatics (left) Mounting position of the pneumatic connections on the right or left of the display
Sprache/Language	16.2	–	–	→ [English]/Deutsch/Français Language of on-site operation at the positioner
Set-up is completed.	16.3	–	–	→ Confirm to exit the display start-up.

16.2 Behavior of menu items when reset functions are used

Menu item		Reset diagnosis	Reset (standard)	Reset (advanced)	Reset initialization
Target operating mode	1		x	x	x
Set point (open-loop control)	2		x	x	x
Manual set point (MAN)	3		x	x	x
Reason for fail-safe position	4				
Change reading direction or Reading direction	5			x	
User level	6				
Actuator	7.1		x	x	x
Pin position	7.5		x	x	x
Pin position	7.6		x	x	x
Pin position	7.7		x	x	x
Nominal range	7.10		x	x	x
Nominal range	7.11		x	x	x
Nominal range for linear actuator (expert) or Nominal range	7.12		x	x	x
Max. nom. range	7.16		x	x	x
Detected nominal range	7.17		x	x	x
Fail-safe position	7.20		x	x	x
Initialization mode	7.24		x	x	x
Set point (open-loop control)	7.28		x	x	x
Adopt valve position 1	7.29		x	x	x
First valve position	7.30		x	x	x
Adopt valve position 2	7.31		x	x	x
Second valve position	7.32		x	x	x
Current valve position	7.35		x	x	x
Direction of rotation	7.36		x	x	x
Volume booster	7.51		x	x	x
Direction of action (actuator)	7.52		x	x	x
Pressure limit active	7.57		x	x	x
Pressure limit	7.58		x	x	x
Result of last initialization	7.83		x	x	x
Result of last zero calibration	7.84		x	x	x

Menu item		Reset diagnosis	Reset (standard)	Reset (advanced)	Reset initialization
Result of last valve signature	7.85		x	x	x
Actuator	7.95.1		x	x	x
Pin position	7.95.5		x	x	x
Pin position	7.95.6		x	x	x
Pin position	7.95.7		x	x	x
Nominal range	7.95.10		x	x	x
Nominal range	7.95.11		x	x	x
Fail-safe position	7.95.20		x	x	x
Initialization mode	7.95.24		x	x	x
Volume booster	7.95.51		x	x	x
Direction of action (actuator)	7.95.52		x	x	x
Pressure limit	7.95.58		x	x	x
T98 (open)	7.95.70		x	x	x
T98 (close)	7.95.74		x	x	x
Loop gain (supply)	7.95.80		x	x	x
Loop gain (exhaust)	7.95.87		x	x	x
Lower w-range value	8.1.1		x	x	
Upper w-range value	8.1.2		x	x	
Direction of action	8.1.6		x	x	
Characteristic	8.1.9		x	x	
Lower x scaling	8.1.10		x	x	
Upper x scaling	8.1.11		x	x	
Lower x-range value	8.1.12		x	x	
Upper x-range value	8.1.13		x	x	
Ramp time (rising)	8.1.20		x	x	
Ramp time (falling)	8.1.22		x	x	
Travel/sec. (rising)	8.1.25		x	x	
Travel/sec. (falling)	8.1.27		x	x	
Lower end position	8.1.40		x	x	
End position $w \leq$ (set point cutoff decrease)	8.1.41		x	x	
Upper end position	8.1.44		x	x	
End position $w \geq$ (set point cutoff increase)	8.1.45		x	x	

Appendix A (configuration instructions)

Menu item		Reset diagnosis	Reset (standard)	Reset (advanced)	Reset initialization
Firmware version	8.2.1.5				
Hardware version	8.2.1.6				
Serial number	8.2.1.7				
Activate integral-action component	8.7.1		x	x	x
Deactivation of integral action in upper end position	8.7.3		x	x	x
Deactivation of integral action in lower end position	8.7.4		x	x	x
Adaptation of integral-action component	8.7.6		x	x	x
Current dead band (integral-action component)	8.7.8		x	x	x
User-defined control parameters	8.7.10		x	x	x
Loop gain (supply)	8.7.13		x	x	x
Kp (supply)	8.7.15		x	x	x
Ki (supply)	8.7.16		x	x	x
Kd (supply)	8.7.17		x	x	x
Loop gain (exhaust)	8.7.20		x	x	x
Kp (exhaust)	8.7.22		x	x	x
Ki (exhaust)	8.7.23		x	x	x
Kd (exhaust)	8.7.24		x	x	x
Software restriction (supply)	8.7.30		x	x	x
End position (optimized)	8.7.70		x	x	x
Module status	8.10.3				
Identification	8.10.4				
Terminal designation	8.10.6.1		x	x	
Function	8.10.6.2				
Configuration	8.10.6.3		x	x	
Action upon active binary input	8.10.6.4		x	x	
Fixed value over binary input	8.10.6.5		x	x	
Edge control	8.10.6.6		x	x	
Current state	8.10.6.7				
Function	8.10.6.66				
Position transmitter's direction of action	8.10.6.67		x	x	
Error message at position transmitter	8.10.6.68		x	x	

Menu item		Reset diagnosis	Reset (standard)	Reset (advanced)	Reset initialization
Limit			x	x	
Current state					
Signal of analog output	8.10.6.69				
Current state					
Signal analog output					
Start DO test.					
Start AO test.	8.10.6.70				
Test signal of analog output	8.10.6.71		x	x	
Test mode	8.10.6.72		x	x	
Module status	8.10.9				
Identification	8.10.10				
Terminal designation	8.10.12.1				
Function	8.10.12.2				
Configuration	8.10.12.3		x	x	
Action upon active binary input	8.10.12.4		x	x	
Fixed value over binary input	8.10.12.5		x	x	
Edge control	8.10.12.6		x	x	
Current state	8.10.12.7				
Function	8.10.12.66				
Mode			x	x	
Edge control			x	x	
Function					
Function					
Position transmitter's direction of action	8.10.12.67		x	x	
Error message at position transmitter	8.10.12.68		x	x	
Error message in case of 'Function check' condensed state	–				
Error message in case of 'Maintenance required' and 'Out of specification' condensed states	–		x	x	
Limit			x	x	
Current state					
Signal of analog output	8.10.12.69				

Appendix A (configuration instructions)

Menu item		Reset diagnosis	Reset (standard)	Reset (advanced)	Reset initialization
Current state					
Signal analog output					
Start DO test.					
Start AO test.	8.10.12.70				
Test signal of analog output	8.10.12.71		x	x	
Test mode	8.10.12.72		x	x	
Module status	8.10.20				
Identification	8.10.21				
Terminal designation	8.10.22.1				
Function	8.10.22.20				
Mode	8.10.22.21				
Edge control	8.10.22.22				
Limit	8.10.22.25				
Current state	8.10.22.26				
Start DO test.	8.10.22.27				
Test mode	8.10.22.28				
Terminal designation	8.10.23.1				
Function	8.10.23.20				
Mode	8.10.23.21				
Edge control	8.10.23.22				
Limit	8.10.23.25				
Current state	8.10.23.26				
Start DO test.	8.10.23.27				
Test mode	8.10.23.28				
Terminal designation	8.10.24.1				
Function	8.10.24.20				
Mode	8.10.24.21				
Edge control	8.10.24.22				
Limit	8.10.24.25				

Menu item		Reset diagnosis	Reset (standard)	Reset (advanced)	Reset initialization
Current state	8.10.24.26				
Start DO test.	8.10.24.27				
Test mode	8.10.24.28				
Select test	8.10.24.30				
Test result	8.10.24.30				
External position sensor status	8.10.38				
Terminal designation	8.10.40.1				
External position sensor signal (scaled and filtered)	8.10.40.41				
Power line frequency filter	8.10.40.43				
Valve position	8.10.40.46				
Mid-position of external position sensor	8.10.40.47				
External position sensor ID	8.10.40.50				
Pressure sensors active	8.10.46.1				
OUTPUT 38: pressure	8.10.46.2				
Supply pressure	8.10.46.4				
Pressure sensors installed	8.10.46.10				
HART communication locked	8.20.1			x	
Fixed value (communication)	8.20.3		x	x	
Fixed value (communication)	8.20.4		x	x	
Polling address	8.20.7			x	
Loop current value	8.20.8			x	
Tag no.	8.20.12			x	
Tag no. (long)	8.20.15			x	
Preambles	8.20.18			x	
Find device flag	8.20.21			x	
Final assembly number	8.20.24			x	
Valve position	10.1				
Valve position	10.2				
Set point	10.10				
Manual set point (MAN)	10.11				
Set point after filter	10.13				

Appendix A (configuration instructions)

Menu item		Reset diagnosis	Reset (standard)	Reset (advanced)	Reset initialization
Fixed value (communication)	10.14				
Fixed value (communication)	10.15		x	x	
Fixed value over binary input	10.16		x	x	
Fixed value over binary input	10.17		x	x	
Set point deviation	10.30				
Current operating mode	10.35				
Reason for fail-safe position	10.38				
OUTPUT 38: pressure	10.45				
Supply pressure	10.47				
Temperature inside device	10.55				
Air humidity	10.60				
Total valve travel limit x 1000	12.1.20		x	x	
Lag time for set point deviation	12.1.30		x	x	
Tolerance band for set point deviation +/-	12.1.31		x	x	
OUTPUT 38: pressure	12.3.16				
Supply pressure	12.3.18				
Total valve travel	12.3.40	x	x	x	
Max. temperature inside device	12.3.50		x		
Min. temperature inside device	12.3.52		x		
Operating hours counter	12.3.60				
Number of initializations	12.3.65				
Number of zero calibrations	12.3.66				
Result of last valve signature	12.5.6.4				
Start PST	12.8.1.1				
Result or Result of last test ¹⁾	12.8.1.5				
Test status	12.8.1.6	x	x	x	
Canceled: x monitoring	12.8.1.10	x			
Start FST	112.8.2.1				
Result or Result of last test ¹⁾	12.8.2.5				
Test status	12.8.2.6	x	x	x	
Start dead band test	12.8.3.1				
Result or Result of last test ¹⁾	12.8.3.5				
Start repetition test (valve signature IP)	12.8.5.1				
Start repetition test (valve signature)	12.8.4.1				
Result or Result of last valve signature	12.8.4.5				

Menu item		Reset diagnosis	Reset (standard)	Reset (advanced)	Reset initialization
Condensed state	12.3.2.1				
Start-up [condensed state]	---				
Start-up	12.3.2.2				
Initialization error	12.3.2.3				
Incorrect operating mode or Init: incorrect operating mode ²⁾	12.3.2.4		x	x	x
Confirm status message	12.3.2.5				
Travel too small or Init: travel too small ²⁾	12.3.2.6		x	x	x
Confirm status message	12.3.2.7				
Rated travel not achieved or Init: rated travel not achieved ²⁾	12.3.2.8		x	x	x
Confirm status message	12.3.2.9				
No movement or Init: no movement ²⁾	12.3.2.10		x	x	x
Confirm status message	12.3.2.11				
Pin position or Init: pin position ²⁾	12.3.2.12		x	x	x
Confirm status message	12.3.2.13				
Canceled (control accuracy) or Init: canceled (control accuracy) ²⁾	12.3.2.14				
Confirm status message	12.3.2.15				
Oscillation or Init: oscillation ²⁾	12.3.2.16				
Confirm status message	12.3.2.17				
End position not reached or Init: end position not reached ²⁾	12.3.2.18				
Confirm status message	12.3.2.19				
Low control accuracy or Init: low control accuracy ²⁾	12.3.2.20				
Confirm status message	12.3.2.21				
Positioner not initialized or Init: positioner not initialized ²⁾	12.3.2.22				
Initialization canceled (external) or Init: canceled externally ²⁾	12.3.2.23		x	x	x
Confirm status message	12.3.2.24				
Angle limitation or Init: angle limitation ²⁾	12.3.2.25				
Confirm status message	12.3.2.26				
Timeout or Init: timeout ²⁾	12.3.2.27				
Confirm status message	12.3.2.28				
Zero calibration error	12.3.2.29				
Timeout for detection of zero	12.3.2.30		x	x	x
Confirm status message	12.3.2.31				
Zero calibration: shift >>	12.3.2.32		x	x	x
Configuration	12.3.2.33				

Appendix A (configuration instructions)

Menu item		Reset diagnosis	Reset (standard)	Reset (advanced)	Reset initialization
Pressure sensors failed	12.3.2.34				
Combination of options or Combination of options invalid ²⁾	12.3.2.35				
Forced venting switch incorrect	12.3.2.36				
Binary input option A active	12.3.2.37				
Binary input option B active	12.3.2.38				
External position sensor error	12.3.2.39				
Process data	12.3.2.40				
Operating mode not AUTO	12.3.2.41				
Forced venting function	12.3.2.42				
Test in progress	12.3.2.43				
Emergency mode active	12.3.2.44				
Control valve diagnosis	12.3.2.45				
No supply pressure	12.3.2.46				
Low supply pressure	12.3.2.47				
Supply pressure > 7 bar	12.3.2.48				
Friction change (open pos.)	12.3.2.49				
Friction change (mid-position)	12.3.2.50				
Friction change (closed pos.)	12.3.2.51				
Valve signature failed	12.3.2.52				
Spring possibly broken	12.3.2.53				
Broken spring detected	12.3.2.54				
Pneumatic leakage	12.3.2.55				
PST	12.3.2.56				
PST: cancellation criteria met	12.3.2.57	x	x	x	
PST: start criteria not met	12.3.2.58	x	x	x	
FST	12.3.2.59				
FST: cancellation criteria met	12.3.2.60	x	x	x	
FST: start criteria not met	12.3.2.61	x	x	x	
AMR signal outside range	12.3.2.62				
Confirm status message	12.3.2.63				
Hardware fault	12.3.2.64				
Limit for total valve travel exceeded	12.3.2.65	x	x	x	
Lower end position shifted	12.3.2.66	x	x	x	
Confirm status message	12.3.2.67				
Upper end position shifted	12.3.2.68	x	x	x	

Menu item		Reset diagnosis	Reset (standard)	Reset (advanced)	Reset initialization
Confirm status message	12.3.2.69				
Dynamic stress factor exceeded or Dynamic stress factor active ²⁾	12.3.2.70	x	x	x	
Set point deviation	12.3.2.71				
Brownout	12.3.2.72		x	x	
Confirm status message	12.3.2.73				
Current too low ($w < 3.7$ mA)	12.3.2.74				
IP shutdown ($w < 3.85$ mA)	12.3.2.75				
Current too high ($w > 22$ mA)	12.3.2.76				
Temperature inside device below min. limit	12.3.2.77				
Temperature inside device above max. limit	12.3.2.78				
Angle limitation	12.3.2.79				
Confirm status message	12.3.2.80				
Logging suspended	12.3.2.81				
Confirm status message	12.3.2.82				
Operating range in CLOSED position	12.3.2.83	x	x	x	
Operating range in max. OPEN position	12.3.2.84	x	x	x	
Operating range shifting towards CLOSED position	12.3.2.85	x	x	x	
Operating range shifting towards max. OPEN position	12.3.2.86	x	x	x	
Limited working range: lower range	12.3.2.87	x	x	x	
Limited working range: upper range	12.3.2.88	x	x	x	
Reset diagnosis	14.1				
Reset (standard)	14.2				
Reset (advanced)	14.3				
Restart	14.6				
Reset initialization	14.15				
Reading direction	16.1			x	
Sprache/Language	16.2			x	
Set-up is completed.	16.3				

16.3 Valve characteristic selection

The characteristics that can be selected in menu item **8.1.4** are shown in the following in graph form.

i Note

A characteristic can only be defined (user-defined characteristic) using an operating software (e.g. SAMSON's TROVIS-VIEW or DD/DTM/EDD).

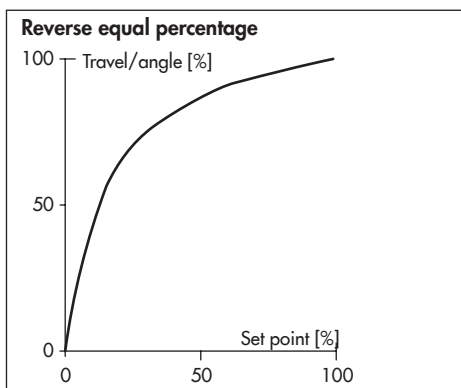
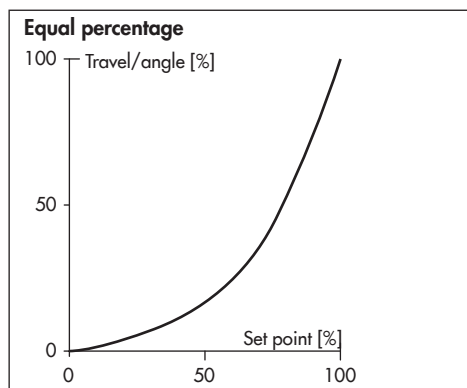
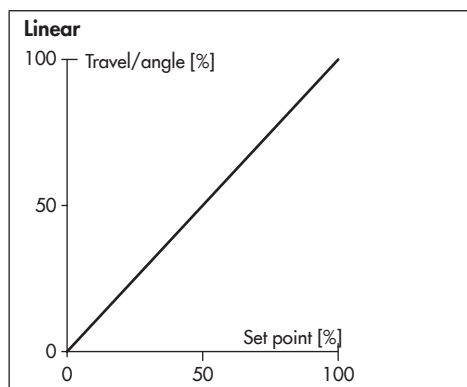

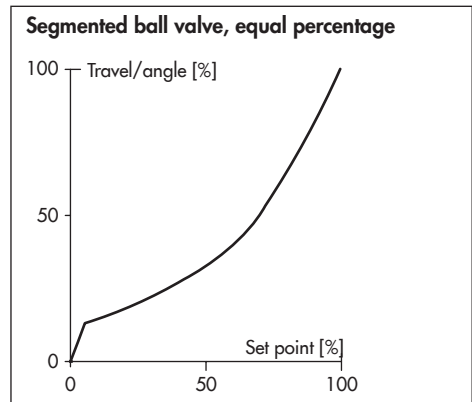
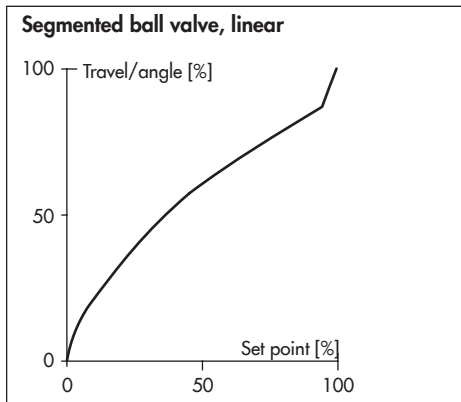
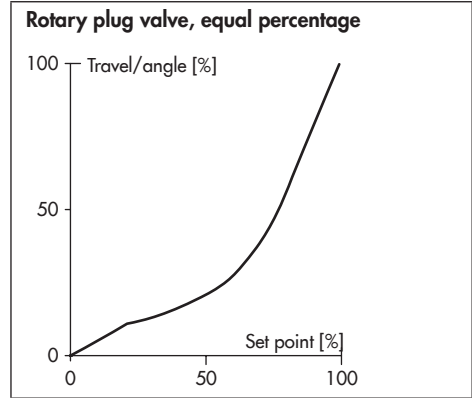
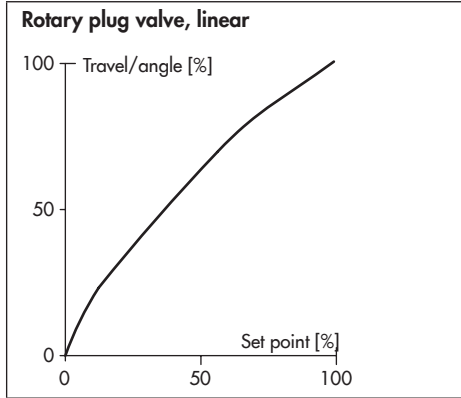
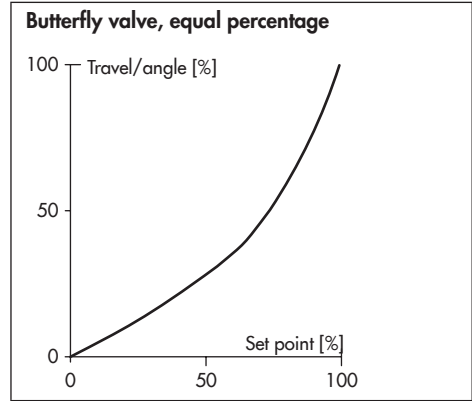
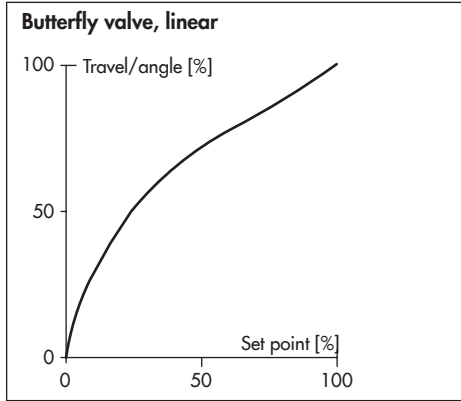

17 Appendix B

17.1 After-sales service

Contact our after-sales service for support concerning service or repair work or when malfunctions or defects arise.

You can reach our after-sales service at aftersalesservice@samsongroup.com.

Addresses of SAMSON AG and its subsidiaries

The addresses of SAMSON AG, its subsidiaries, representatives and service facilities worldwide can be found on our website (www.samsongroup.com).

Required specifications

Please submit the following details:

- Order number and position number in the order
- Device type: TROVIS 3730-3
- Material number
- Serial number
- Software version

Material number, serial number and software version (see the 'Markings on the device' chapter for nameplate details)

EB 8484-3 EN



SAMSON AKTIENGESELLSCHAFT
Weismüllerstraße 3 · 60314 Frankfurt am Main, Germany
Phone: +49 69 4009-0 · Fax: +49 69 4009-1507
samson@samsongroup.com · www.samsongroup.com