



AND
EVERYTHING
FLOWS

NEXT **VALVE**
GENERATION
TYPE 251GR



The SAMSON 251GR Valves are part of the innovative SMS Series designed to meet the demands of the most challenging process applications. Their modular design simplifies maintenance and service while allowing for seamless retrofitting even after installation.

Selected applications:

- Chemicals
- Petrochemicals
- Oil and gas
- Special applications

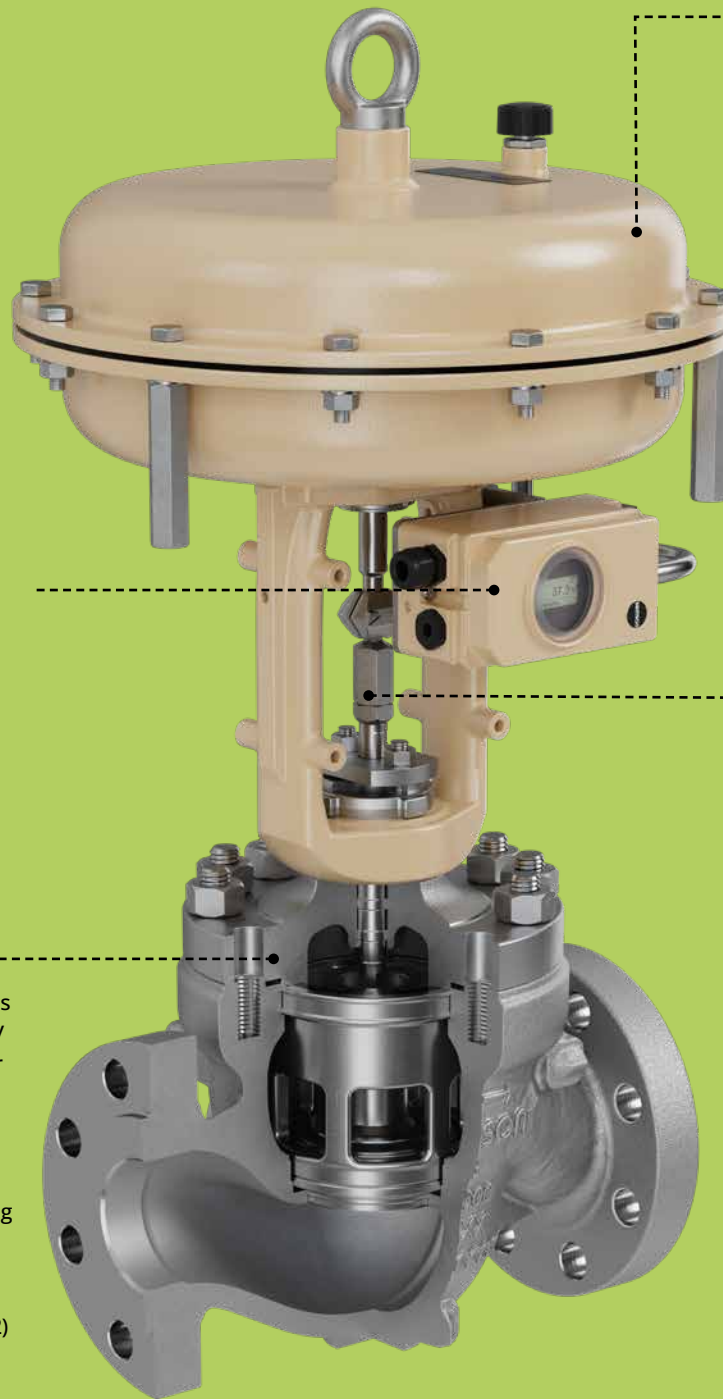

Optimized plant integration

- Rolling diaphragm for easy maintenance and minimal wear during operation
- Very low external air loss
- Lower installation heights

Effortless integration

- Smart positioners with automatic initialization
- Optional direct attachment for easy mounting

A new benchmark of performance

- Bellows can be replaced while the valve is installed (easy maintenance)
- Larger guiding stem diameter for improved stability as well as reduced noise and wear
- PTFE and graphite packings
- Low-emission packings

The modular revolution

- Screwed-in or clamped-in seats or cage trims in the same body
- Optimized flow path allows for improved flow rate
- Trims fully replaceable in the field
- Retrofittable trims for noise reduction and critical operating conditions
- High-temperature pressure balancing with leakage class V (DIN EN 60534-4/ANSI FCI 70-2)

Technical data	
Nominal size	DN 15 to 200/NPS ½ to 8
Pressure rating	PN 16 to 160/Class 150 to 900
Temperatures	-50 to +550 °C/-58 to +1022 °F
Body material	Cast steel (1.0619/A216 WC, 1.7357/A217 WC6), cast stainless steel (1.4408/A351 CF8M)
K _{vs} coefficients C _v coefficients	0.26 to 720 0.3 to 835
Leakage class according to IEC 60534-4/ANSI FCI 70-2	Standard: IV High performance: V
Characteristic	Equal percentage · Linear · Modified linear · On/off



More information on our website.



251GR valve body with different trims

251 GR STANDS FOR INNOVATIVE VALVE DESIGN

The valve body is designed relying on over 100 years of experience and validated by state-of-the-art simulation technology. Analyses included machine learning algorithms developed at SAMSON and CFD (Computational Fluid Dynamics) simulations.

The objective was to develop a rugged valve body with the best flow performance and coefficients for a small carbon footprint and high energy efficiency.

The design and safety of the SMS Series were tested extensively at the development stages and exceed the standards' requirements by far.



AND
EVERYTHING
FLOWS

NEXT VALVE GENERATION

TYPE 251GR